PROGRAMMABLE DC POWER SUPPLY

User's Manual

APS-7203
APS-7205



www.tmatlantic.com

PROGRAMMABLE DC POWER SUPPLY

Thanks for using our products, please read this manual thoroughly before operation.

CONTENTS

Safety Symbols 3

Product Introduction 4

 Product Overview 4

 Additional Features 4

Specifications of Product 5

Precautions before operation 6

 Packaging Demolition 6

 Checking the voltage 6

 Operating Enviroment 7

Panel Introduction 7~9

 Ichnography of the Front Panel 7

 Ichnography of the Rear Panel 8

 Function Description 8~9

Operating method 10~12

 Output Voltage Setting 10

 Output Current Setting 10

 OCP Setting 11

 Voltage / Current Step Setting 11

 Data Storing and Recalling Setting 11

 Setting of Automatic sequential implementation 11

 operation of Series-parallel mode 12

 Communication Settings 12

Maintenance 13~15

 Fuse Replacement 13

 Adjustment and Calibration 14

 Cleaning Protection 15

[Step 3]

After finishing the voltage zeroing of three channels, which are also saved, move the cursor to **[CURRENT] of [CH1]**. Connect the ammeter and adjust the knob to make the current to be 0mA when selecting the channel. Then press **[ENTER]** to finish the zeroing storage of the channel's current. Move the cursor down to process the current zeroing storage of channel 1 and channel 2 with the same procedure.

Zero Correct		H
CH1Votage	Current	+
CH2Votage	Current	
CH3Votage	Current	

[Step 4]

After completing step 3, move the cursor to the left; press key 2 into the interface of range calibration. When the cursor is moved to the corresponding channel, you can adjust the output voltage by using the shuttle knob. And you can also regulate the voltage of the corresponding channel to be 32V(the smallest unit of the test voltmeter is Mv). Press **[ENTER]** and then the calibration data of the corresponding channel is stored. Move the cursor down into the calibration of another channel. And the operation is the same.

Output Correct		H
CH1Votage	Current	+
CH2Votage	Current	
CH3Votage	Current	

[Step 5]

Connect the ammeter and adjust the knob to make the current be 5A(or 3A), after finishing the maximum voltage calibration of the three channels and storing them respectively. Press **[ENTER]** to save the current of the channel. Then move the cursor to carry on with the current calibration and storage of channel 2 and channel 3.

Output Correct		H
CH1Votage	Current	+
CH2Votage	Current	
CH3Votage	Current	

3. Cleaning

Use the wet cloth or cleanser to wipe the shell to make the apparatus sanitary. Never use scrub cloth or solvents in order not to damage the outer portion of the instrument.

2. Adjustment And Calibration

2.1.1 Preparation

- a. 30 minutes warm up before calibration.
- b. Ambient temperature: $23 \pm 5^{\circ}\text{C}$, Humidity: Under RH80%.
- c. Select six and a half digital voltmeter; the current test range is more than 5A(PPS3203T-3S 's test range can be only more than 3A).

2.1.2 Output Calibration Steps:

[Step 1]

Press **[SHIFT][4]** to appear Password input window, input Password (vary with different models) by using the number key, press **[ENTER]** key. When the value has been input by mistake, it can automatically clear the input value and input again. Press **[ENTER]** and then it will return to the calibration interface.

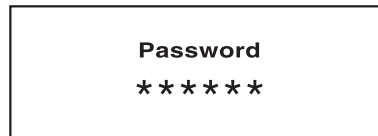

[Step 2]

Input the correct password into the zeroing interface. At this time, the cursor is controlled by key 8, 2, 4, 6 (up, down, left, right). Set the cursor to the calibrated item of the corresponding channel and then use the shuttle knob to adjust input parameters and regulate the voltage of the corresponding channel to be 0V (the smallest unit of test voltmeter is mV). Press **[ENTER]** and the calibration data of the corresponding channel is stored. Move the cursor down to calibrate another channel. The procedure is the same.

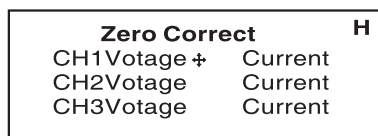

Safety Symbols

In order to protect the machine, these symbols may appear in this manual or on the product :



WARNING: Warning statements identify condition or practices that might result in injury or loss of life.



CAUTION: Caution statements identify conditions or practices that could result in damage to this product or other property.



Ground: Ground terminal



Frame or chasis terminal



Safety Precautions

1. Handling or storage, the use of pressure or vibration should be avoided.
2. Without the professional technician, you should not dismantle the machine by yourself when it does not work in order not to result in the change of its characteristics.
3. Note that the use of power supply 230V/115V and fuse specifications instructions.
4. The machine using three linear power supply, to ensure that the machine casing and power of a good grounding protection.
5. To avoid the above +10 V voltage outside on the signal output.
6. Range of operating environment $0^{\circ}\text{C} \sim 40^{\circ}\text{C}$; and should be avoided at high temperature, high humidity and magnetic interference of the operation .

Product Overview

Programmable Power Supply is controlled by Micro Processor Unit (MPU) that can easily connect communication interface RS-232 or USB to computer in order to satisfy users' demand for auto-testing and auto-control. The voltage and current are completely controlled by 12 bits D/A Converter with higher resolution and accuracy. Also, the digitalization of system makes a speedy, precise and convenient input of information controlled by keyboard. The adjustment of voltage/current is made by software calibration without manual error that will increase the preciseness of the instrument. The function of Over Voltage Protection (OVP) and Over Current Protection (OCP) is set with software and detected with hardware to achieve protected function precisely and speedily in order to secure users from danger by using the instrument.

Additional Features

- Programmable power supply with an overall digitalization.
- Three-linear separately adjustable output.
- The 192×64 LCD Display can appear multiple settings and measurement results simultaneously.
- Windows-based intelligent intuitive interface, user-friendly operation.
- High stability and low drift.
- OVP, OCP and over temperature protection.
- Intelligent control fan (Vary with different output power.).
- Built-in buzzer as a warning prompt.
- Accurate calibration software.
- The design of new panel and volume-reducing design.
- Jog knob (microtuning and macrotuning)
- 90 groups storage space setting.
- Operation modes: parallel and series
- 1 s' timing resolution.

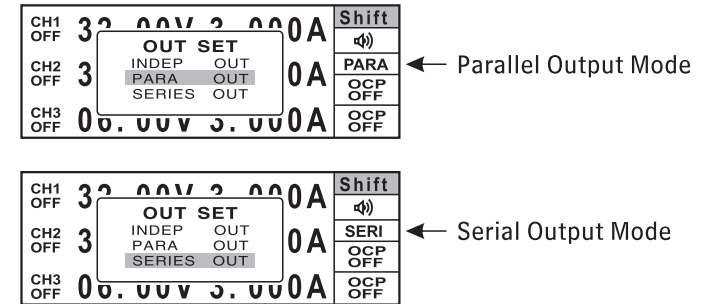

8. Communication Setting

Press **[SHIFT][COMM]** into the interface of communication setting and use knob to switch the cursor to the corresponding place. And you can set the power address, communication speed and data bit by using knob to switch the cursor to the corresponding parameters, which are to be revised and setted.

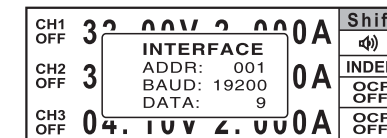

General Maintenance

The following instructions are executed by qualified personnel only. To avoid electrical shock, do not perform any servicing other than the operating instructions unless you are qualified to do so.

1. Fuse Replacement

If the fuse blows, the display will not light and the power supply will not operate. The fuse should not normally open unless a problem has developed in the unit. Try to determine and correct the cause of the blown fuse, then replace a fuse with the correct rating type. Please refer to the comparison table between voltage and fuse.



WARNING: For continued fire protection. Replace fuse only with 250V fuse of the specific type and rating, and disconnect power cord before replacing fuse.

5.2 Data recalling setting

Press **[SHIFT][STORE]** into menu screen, after moving the cursor to the delay parameter of storage address to be called out, press the button **[AUTO]**, then shape identifier “■” appears, which says the group is the output parameters of the corresponding channels.

For example: call out parameters of CH1 channel storage address "03" to the present state of setting equipment. press **[SHIFT][RECALL]** into menu screen. After using knob to switch the cursor to time delay parameter of address 03, press **[AUTO]**, and then shape identifier “■” appears; namely complete call setting.

6. Automatic sequence execution

In the main window, click **[AUTO]**, output way of interface displays AUTO by pressing **[OUTPUT]**. Press **[OUTPUT]** then the output is output circulatingly according to the setted voltage, current, and delay parameter. Press **[AUTO]** again, and then output of automatical sequence execution can be cancelled.

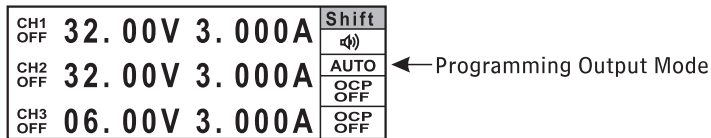

7. Series and parallel operation mode

Click **[SHIFT][PARA/SER]** into parallel operation mode; select picture. use the shuttle knob to select the output mode. Press **[ENTER]** for confirmation and return to the main interface. When the machine works in series and parallel operation mode, the output voltage and current CH2 for the master, CH1 outputs automatically following CH2 output.

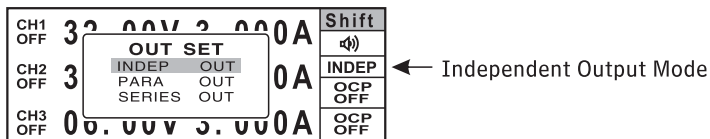

Technical specifications

Note: the following indexes are tested after 20 minutes' warming-up.

Specifications		PPS3203T-3S	PPS3203T-2S	PPS3205T-3S	PPS3205T-2S
Output	Voltage	0~32V x 2, 0-6V 1	0~32V x 2, 2.5V/3.5/5Vx1	0~32V x 2, 0-6V x 1	0~32V x 2, 2.5V/3.5/5Vx1
	Current	0~3A x 3	0~3A x 2 3A x 1	0~5A x 2 0~3A x 1	0~5A x 2 3A x 1
Load Effect	Voltage	≤3mV(≤8mV rated current>3.0A)			
	Current	≤3mA(≤5mA rated current>3.0A)			
Power Effect	Voltage	≤3mV(AC ± 5%)			
	Current	≤3mA			
Resolution	Voltage	10mV			
	Current	1mA (2mA rated current>3A)			
Set Accuracy (25 ± 5°C)	Voltage	≤0.05% + 10 mV(+20 mV rated voltage>36V)			
	Current	≤0.1% + 5ma(+10 mA rated current>3.0A)			
Ripple (20Hz-20MHz)	Voltage	Ripple≤1 mVrms			
	Current	≤3mArms(≤5mArms rated current>3.0A)			
Temperature Coefficient (0~40°C)	Voltage	100ppm+3mV			
	Current	100ppm+3mA			
Read back Resolution	Voltage	10 mV			
	Current	1mA(2mA rated current>3.0A)			
Response Time	Voltage rise	10%~90%≤100ms			
	Current fall	90%~10%≤10ms(≥10% rated load)			
Readback Temperature Coefficient	Voltage	≤100ppm+10 mV			
	Current	≤150ppm+10 mA			
Drift	Voltage	≤100ppm+10 mV			
	Current	≤150ppm+10 mA			
Serial synchronous operation	Serial synchronous error	≤0.1%+20 mV			
	Series(Load)	20 mA			

Parallel Synchronous Operation	Set Accuracy	Voltage $\leq 0.05\% + 20$ mV Current $\leq 0.1\% + 20$ mV
	Load regulation	Voltage ≤ 5 mA Current ≤ 6 mA
	Power regulation	Voltage ≤ 3 mV Current ≤ 6 mA
Memory		Store/Recall points 0~90
Timer	Setting time	1s~9999s
	Resolution	1s
	Function	Auto Step running
Interface		RS232,USB interface
Mechanical Spec.	Dimensions	230 (W) × 140 (H) × 380 (L) mm
	Weights	10Kg
Operation Environment		Indoor use, Altitude up to 2000 m

Precautions before operation

1. Unpacking the Instrument

The product has been fully inspected and tested before shipping from the factory. Upon receiving the instrument, please unpack and inspect it to check if there is any damage caused during transportation. If any sign of damage is found, notify the bearer or the dealer immediately.

2. Checking the Line Voltage

The product can be applied by any kind of line voltages shown in the table below. Before connecting the power plug to an AC line outlet, make sure the voltage selector of the rear panel is set to the correct position corresponding to the line voltage. It might be damaged the instrument by connecting to the wrong AC line voltage.

When line voltages are changed, replace the required fuses shown as below:

MODEL	Line Voltage	Input Range	Fuse	MODEL	Line Voltage	Input Range	Fuse
(110V)	110V	105V-115V	T5A 250V	(220V)	220V	209V-231V	T3A 250V
(110V)	110V	105V-115V	T8A 250V	(220V)	220V	209V-231V	T5A 250V

Example: Set current at 1.000A.

Press **[I SET][1][.]][0][0][0][ENTER]**

When the load current through output terminal exceeds the setting value, the instrument is operated in the C.C. mode, if not exceeds the setting value, the instrument is operated in the C.V. mode.

3. Over Current Protection Setting

Click **[OCP]**, which can open OCP mode. This instrument can display OCP ON; OCP mode is cancelled by pressing **[SHIFT][OCP]**.

4. Voltage/Current Step Setting

In the shuttle knob input conditions, by pressing F/C, the voltage and the current state of bounded steps can be changed.

5. The data storage and call setting

5.1 The data storage setting

Press **[SHIFT][STORE]** into menu screen, and use the cursor to the corresponding switch knob, and then press **ENTER** into 30 group; move the direction key (8,2,4,6) to select voltage, current and delay time; the selected items are the white shows; press **ENTER**, then you can input data directly; after that, press **ENTER**, then this is stored.

CH1 OFF	32	00V	2	000A	Shift
CH2 OFF	3			0A	INDEP
CH3 OFF	00.	00V	5.	000A	OCP OFF

CH1 STORE	
1 :	32.00 V 2.000A 0001S □
2 :	43.50 V 1.253A 0002S □
3 :	55.19 V 1.376A 0002S ■

Example: set output voltage, current and delay time of the CHI storage address “01” to be 15.00V, 3.00A, 20S. Press **[SHIFT][STORE]** into menu screen, and adjust Wheel knob to switch to CH1 channel. Then press **ENTER** into CH1 storage interface; move the cursor to the voltage, current and delay time respectively, press **ENTER** to input data and then press **ENTER** to store data.

Operation Method

1. Output Voltage Setting

At first, select the wanted channel by pressing **[SHIFT][CHx]**, now the cursor is set to **CHx (x=1, 2 or 3)**. Please refer to the drawing:

Method 1: Set output voltage by pressing **[V SET]** and using number key to key in **[voltage value]**, then press **[ENTER]**.

Method 2: Press **[V SET]** and using knob to input **[voltage value]**, the output voltage setting will be changed immediately, then press **[ENTER]** to terminate the voltage setting.

Obviously, using this method, the output voltage will be changed immediately following the input value through knob.

CH1 OFF	32.00V	3.000A	Shift ⏏
CH2 OFF	32.00V	3.000A	INDEP ⏏
CH3 OFF	06.00V	3.000A	OCF OFF

CH1 OFF	-- --V	3.000A	Shift ⏏
CH2 OFF	32.00V	3.000A	OCF OFF
CH3 OFF	06.00V	3.000A	OCF OFF

Example: Set voltage at 30.00V.

Press **[V SET][3][2][.][0][0][ENTER]**.

2. Output Current Setting:

At first, select the wanted channel by pressing **[SHIFT][CHx]**, now the cursor is set to **CHx (x=1, 2 or 3)**. Please refer to the drawing:

Method 1: Set output current by pressing **[I SET]** and using number key to key in **[current value]**, and **[ENTER]**.

Method 2: Press **[I SET]** and using knob to input **[current value]**, the output current setting will be changed immediately, then press **[ENTER]** to terminate the current setting. Obviously, using this method, the output current will be changed immediately following the input value through knob.

CH1 OFF	32.00V	3.000A	Shift ⏏
CH2 OFF	32.00V	3.000A	INDEP ⏏
CH3 OFF	06.00V	3.000A	OCF OFF

CH1 OFF	32.00V	-- --A	Shift ⏏
CH2 OFF	32.00V	3.000A	INDEP ⏏
CH3 OFF	06.00V	3.000A	OCF OFF



WARNING: To avoid electrical shock the power cord protective grounding conductor must be connected to ground.



CAUTION: To avoid personal injury and fire, disconnect the power cord before removing the fuse holder.

3. Operation Environment

The normal ambient temperature range of this instrument is from 0° to 40°C (32° to 104°F). To operate the instrument, exceeding this specific temperature range may cause damage to the circuits of instrument.



CAUTION: To avoid damage to the instrument, never use it at the temperature of over 40°C.

Panel Introduction

Ichnography of Front Panel as below

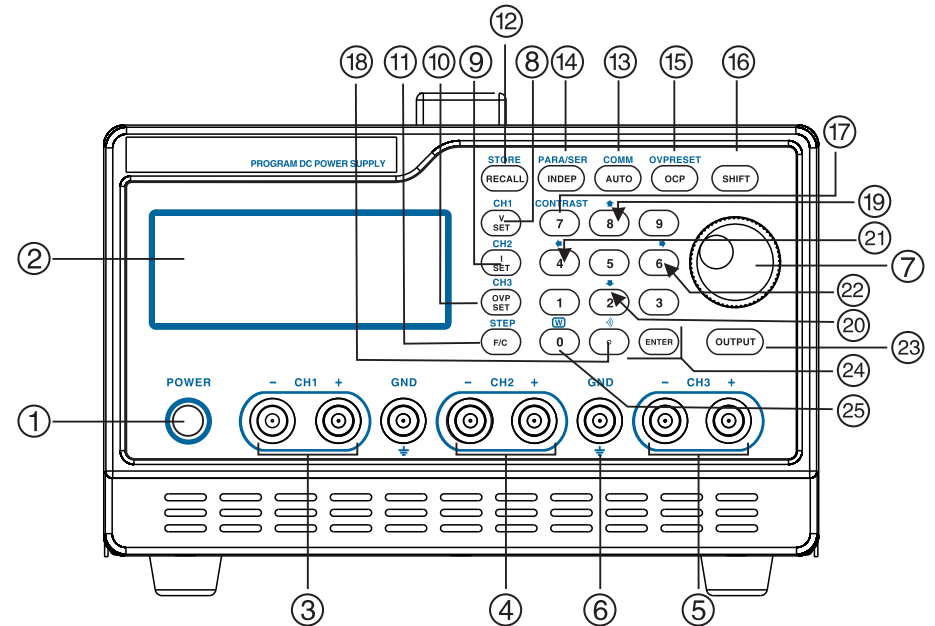

FUNCTION DESCRIPTION AS BELOW

Ichnography of Rear Panel as below

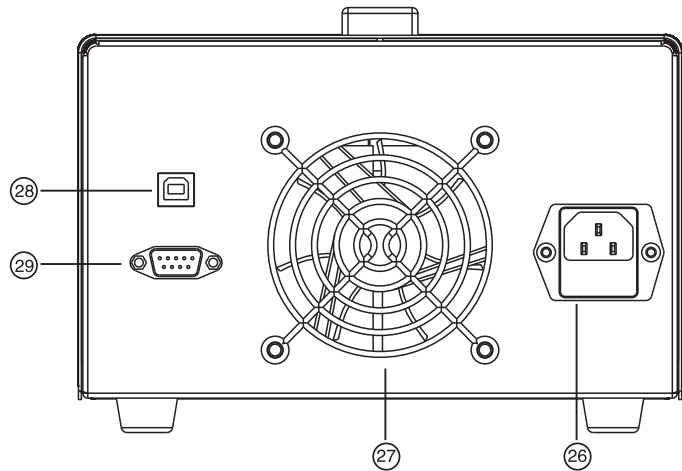

Function description as below:

1	POWER	Press this button to make the power on
2	DISPLAY	The display Settings of voltage and current, output voltage and output current, setting and output condition
3	CH1 OUT	CH1 output terminals
4	CH2 OUT	CH2 output terminals
5	CH3 OUT	CH3 output terminals
6	GND Terminal	Ground terminal connecting to CASE
7	Rotary Encoder	Shuttle knob: it can immediately adjust the output voltage and current steppingly
8	V SET(CH1)	Set Output voltage: Switch to channel 1 by pressing [SHIFT] [CH1] to proceed group setting
9	I SET(CH2)	Set Output current: Switch to channel 2 by pressing [SHIFT] [CH2] to proceed group setting
10	OVP SET(CH3)	Set OVP value: Switch to channel 3 by pressing [SHIFT] [CH3] to proceed group setting

FUNCTION DESCRIPTION AS BELOW

11	F/C (STEP)	Switch input of shuttle knob to be macro-tuning and micro-tuning; you can increase or decrease the steps of the order in the mode of shuttle by pressing F/C
12	RECALL(STORE)	Recall the stored information. Proceed information storing and editing by pressing [SHIFT][STORE] .
13	AUTO(COMM)	Single click namely after entering automatically execute mode. Click [SHIFT] [COMM] into the interface of the communication setting.
14	INDEP (PARA/SER)	Press the [SHIFT][PARA/SER] into parallel selection screen, Single click [INDEP] key to independent output mode
15	OCP (OVP RESET)	OCP on/off open or close OCP Press [SHIFT][RESET] key to clear over-voltage protection
16	SHIFT	The second function selection, clear the selected channel while pressing it.
17	CONTRAST	Proceed the contrast adjustment of the display by pressing [SHIFT][CONTRAST] . The rotary shuttle knob can adjust display contrast; press [ENTER] to exit setting.
18		Turn on/off the buzzer by pressing [SHIFT] [Speaker]
19		Move the cursor upward by pressing [▲] in the condition of storage
20		Move the cursor downward by pressing [▼] in the condition of storage
21		Move the cursor on the left by pressing [◀] in the condition of storage
22		Move the cursor on the right by pressing [▶] in the condition of storage
23	OUTPUT	Turn on or off output by pressing the knob; when you select a channel, you can turn on/off the corresponding channel; when you select no channel, you turn on/off all channels.
24	0~9 “.”, ENTER	Data entry, ENTER Value output
25	, “0”	Press [SHIFT] [Reset] to restore factory settings
26	AC Power Socket	AC Power Socket AC power input terminal
27	Cooling Fan	Cooling Fan
28	Interface	USB interface
29		RS232C communication interface