

OPERATOR'S MANUAL

Baker SterilGARD®III *Advance*^o Biological Safety Cabinet

MODEL
SG403A / SG603A

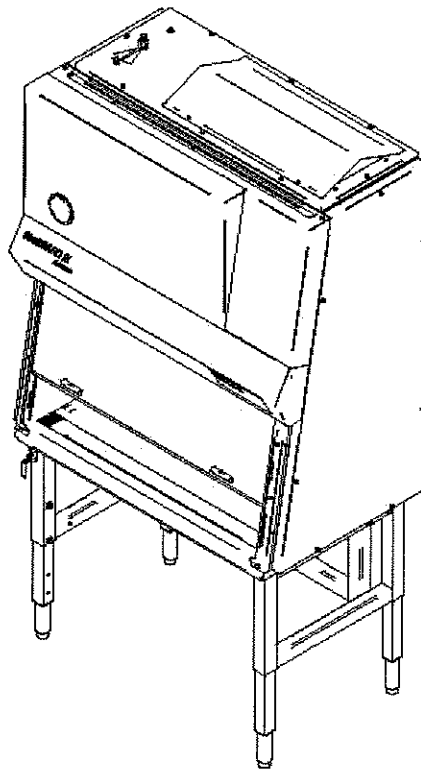

THE BAKER COMPANY

Classification: Class II, Type A2

This manual includes information for installation, operation, maintenance and spare parts. We recommend that it be kept near the cabinet for ready reference.

January 10, 2005
Rev C
Dwg# 333D012

THE BAKER COMPANY

INTRODUCTION AND WELCOME

It is a pleasure to welcome you to the growing number of customers who own and operate Baker biological safety cabinets. As the inventors of the laminar flow biological safety cabinet and the leaders in the field, Baker people take special pride in providing a cabinet that is designed for maximum performance.

Your new SterilGARD®III Advance® cabinet includes many unique features which are included to give you superior performance, simpler maintenance and lower life cycle cost. Your SterilGARD®III Advance® cabinet is designed for both safety and value.

In addition to the high quality you expect from all Baker equipment, this model has been ergonomically designed to provide the lab user with many exciting design features. The revolutionary ergonomic design will help prevent repetitive motion injury, reduce fatigue and lab accidents and enhance productivity.

You will find your SterilGARD®III Advance® cabinet suitable for use not only for research and clinical diagnostic work involving tissue culturing of possibly infectious samples, but also for I.V. drug preparations and other pharmaceuticals that could have adverse health effects on operators and other techniques requiring a contamination-free atmosphere.

Please note that all open-front containment cabinets, including this one, are for use with low to moderate risk agents only. Open-front cabinets do not provide absolute protection for the user. The adequacy of a cabinet for user safety should be determined on-site by an industrial hygienist, safety officer or other qualified person. Remember that you, the owner and user, are ultimately responsible and that you use your cabinet at your own risk.

We recommend that this manual, along with factory test report, be kept near the cabinet for convenient reference by operators and qualified maintenance personnel. If you have any questions about the use or care of your new SterilGARD®III Advance® cabinet, please do not hesitate to contact our Customer Service Department at 800-992-2537 for assistance or e-mail us at bakerco@bakerco.com.

Sincerely,



Dennis Eagleson
President, CEO
The Baker Company, Inc.

TABLE OF CONTENTS

INTRODUCTION	Page i
I FUNCTION AND DESCRIPTION OF THE STERILGARD® III ADVANCE^o	1
Airflow Inside the Biological Safety Cabinet	1
Fig. 1, Airflow Inside Cabinet	1
Positive and Negative Pressure Areas	2
Access to the Work Area	2
Design Details	2-4
Specifications	4-5
II PREPARING THE STERILGARD®III ADVANCE^o FOR USE	6
Checking the Cabinet on Arrival	6
The Uses of a Biological Safety Cabinet	6
Location Within the Laboratory	6-7
Installing the Cabinet	7
Connecting the Exhaust	7-8
Final Connections and Tests	8
III PROPER CABINET USE	9
Operator Controls	9-10
Fig. 2, Operator Controls	9
Ground Fault Circuit Interrupter	10
Start-up Procedure	10-11
Working in the Cabinet Work Space	11
Reacting to Spills	12
Ultraviolet (Germicidal) Light	12
Decontamination	12
Decontamination Procedure.....	12-13
Cleaning and Disinfecting Stainless Steel.....	15
Using Ancillary Equipment	14
About the HEPA Filters	14-15
Operating Procedures	15
IV ON-SITE CHECKS AND MAINTENANCE	16
The Airflow Balance	16-17
Filter Leak Test	17-18
Airflow Smoke Pattern Test	18
Cabinet Integrity Test	18
Electrical Safety Tests	18
Maintenance Notes	19

Replacing the HEPA Filters	20
Changing Filters	20
Fig. 3, Supply Plenum	21
Troubleshooting	22-23
Disassembly Instructions.....	24
APPENDIX	
Dimensional Drawing, Model SG403A / SG603A.....	25-26
Wiring Diagram, Model SG403A / SG603A	27-28
Replacement Parts List	29-30
Stand Assembly Instruction.....	31-
34	
How to Install or Remove a Channel Stand.....	35-36
Infield Fluorescent and Ultraviolet Lamp Replacement.....	37-39
Exhaust Transition System Instructions (CEC / HEC).....	40-46
Airflow Monitor Installation Instructions.....	47-49
O.S.H.A. Federal Register Page. (Biological Hazard Signs).....	51
Warranty	52

I - FUNCTION AND DESCRIPTION OF THE STERILGARD®III ADVANCE°

The SterilGARD®III Advance° is a Class II Type A2 biological safety cabinet of original design. It features vertical laminar airflow and a front access opening. The unit is designed to protect not only the environment and the people using the cabinet, but also the product within from airborne contaminants.

Airflow Inside the Biological Safety Cabinet

The SterilGARD®III Advance° cabinet features The Baker Company's momentum air curtain. See Fig. 1. The stainless steel metal diffuser just below the supply HEPA filter creates a faster airflow behind the sash than over the work zone. The faster airflow in front makes an extremely effective air barrier.

Another feature of the unique Baker design is the high velocity return air slots, which maximize the cabinet's protective capability. It is generally accepted that maintaining containment and a particle free work area is most difficult in the area in which airflow turbulence is greatest — at the intersection of the side walls, the front access opening and the work surface. Turbulence caused by friction will also be found along a cabinet's side walls. In cabinets without high-velocity return air slots, this turbulence may also allow contaminants to escape from the work area, or it may make it possible for unfiltered room air to enter the work area.

The Baker high-velocity return air slots are located along the side walls of the work area opening. Air is drawn into the slots at very high speed, preventing the escape of particulates and ensuring that no unfiltered air enters the work area. Additional high-velocity return air slots are located at the top of the sliding window to prevent gases, vapors or particulates from coming up behind the window and escaping into the laboratory. In the same way, they prevent room air from migrating down behind the window and contaminating the work area.

The airfoil design at the bottom of the sash opening has been designed to maximize containment while allowing comfort when performing procedures in the cabinet. The need for the airfoil in effective biological safety cabinet design has been documented in research conducted by Baker, the pioneers in safety cabinet development. Baker has continued this tradition with the SterilGARD®III Advance°. The 10 degree sloped front feature has also been incorporated into the design to improve ergonomics - to allow the operator to use the cabinet properly without sacrificing comfort or safety.

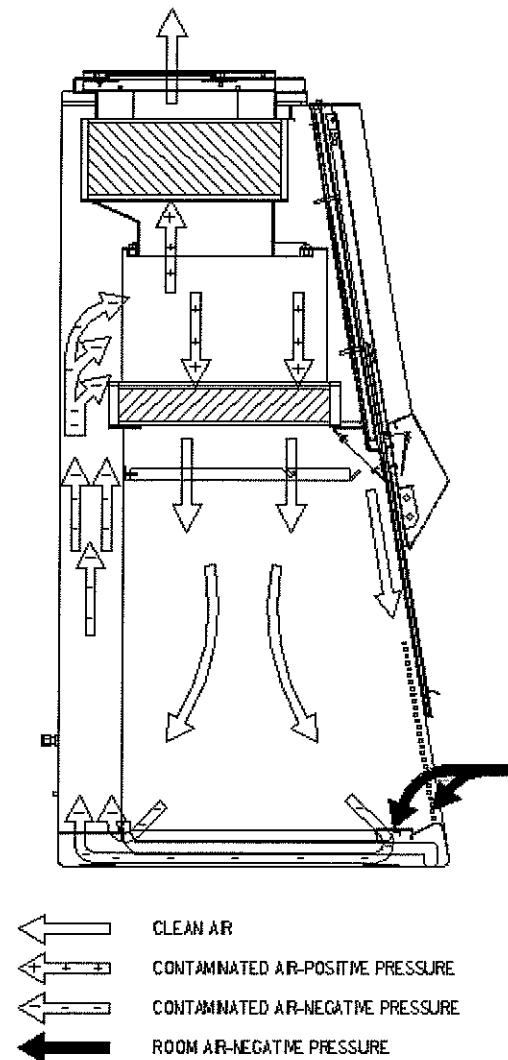

Positive and Negative Pressure Areas

One of the many features that sets the SterilGARD®III Advance° unit apart from other biological safety cabinets is the interaction of positive and negative pressure areas. The small positive pressure plenum is completely surrounded by a negative pressure area so that any particle passing through is bound to be drawn through the blower and trapped in a HEPA filter.

From the small positive pressure plenum, which is shown in Figure 1, a portion of the cabinet airflow is expelled through the exhaust HEPA filter. The remaining air is re-circulated through the supply HEPA filter where it re-enters the work area as better than Class 10 air. Because the cabinet must take in air to replace the air expelled through the exhaust filter, the same volume of room air enters the cabinet through the front access opening and the high velocity return air slots. This air, which does not reach the work area until passing through the supply HEPA filter, completes the air barrier at the front access opening.

All air is combined under the work surface. From here, the contaminated air is pulled, under negative pressure, through a plenum up the rear of the cabinet into the motor-blower, which blows it into a positive pressure plenum. Please note again that the positive pressure plenum is completely surrounded by negative pressure areas. If a leak should occur in a contaminated negative pressure plenum, such as the side wall or rear wall, the negative pressure will create suction and pull air in, not allowing it to escape into the operator's area. If there is a leak from the positive pressure plenum, the surrounding negative pressure area will recapture the contaminated air and recirculate it through a HEPA filter.

Access to the Work Area

For easy entry of apparatus into the work area, SterilGARD®III Advance° has a sliding viewscreen. Its ¼-inch safety plate glass allows excellent visibility, and it may be opened to a height of 19 ¾" to permit placement of items in the work area. The window should be set at a height of 8". An alarm is provided to remind the operator if the window is above or below the set position for using the cabinet. (Section 3 on "Proper Cabinet Use"

explains how to use the viewscreen correctly while the cabinet is in use).

As with other Baker cabinets, the GFCI protected electrical outlets inside the work area have a circuit breaker so that an electrical overload by ancillary equipment won't affect air handling. Overloading with electrical equipment should, of course, be avoided in any case. (See the "Ancillary Equipment" instructions in Section 3 on "Proper Cabinet Use").

Design Details

Performance assurance

Meticulous care in manufacturing is followed by more than 14 separate performance tests prior to shipment of your cabinet. In addition, a complete factory test report on the performance of your cabinet is included at the rear of this manual.

Motor/ blower capacity

A motor/blower's capacity is measured by its ability to provide a nearly constant volume of air as resistance increases because of filter loading. Verification by a simulated filter-loading test has established that your SterilGARD®III cabinet is capable of automatically handling a 60% increase in pressure drop across the filter without reducing total air delivery more than 10%. With the use of the manual speed control, a 180% increase in the pressure drop across the filter can be handled. This results in extended filter life, which relates to significant cost savings over the life of the cabinet.

One-piece interior wall construction

The interior side and rear walls of your SterilGARD's work area are constructed from a single piece of 16-gauge stainless steel. The easy-to-clean 7/16-inch radiused (rounded) corners prevent buildup of contaminants and resist corrosion.

Protective screen

Located under the work surface at the bottom rear and sides of the return-air plenums, a protective screen, integral to the interior walls, is provided to prevent wipes and other paper materials from being drawn into the blower

system. This feature eliminates costly decontamination processes and downtime. The screen affords easy access to waste materials and should be kept clean at all times.

All-metal plenums

The plenums of your SterilGARD®III unit have been constructed entirely of metal in order to provide strength, durability, air-tightness and resistance to deterioration.

Recessed stainless steel work surface

The work surface is constructed of corrosion-resistant 16-gauge type 304 stainless steel, with a satin finish that diminishes light reflection. It is recessed to retain spills, and the radiused corners make for easy cleaning and disinfection.

Cabinet exterior panels

External panel construction is of 16-gauge cold-rolled steel, protected by a smooth white baked enamel finish.

Tested HEPA filters

Both the downflow and exhaust filters in the SterilGARD®III Advance° are scan-tested HEPA filters. They are 99.99% effective on particles of 0.3 micron size. Each filter is scan-tested after installation to assure that there are no leaks >.01% of upstream concentration.

Viewscreen

The cabinet's ¼-inch safety plate glass sliding viewscreen may be opened to 19 ¾" for placement of large items in the work area, and may be fully closed for system shutdown or UV light operation.

Drain valve

A 3/8" diameter stainless steel ball valve in the SterilGARD®III unit is installed for safe and effective drainage of the drain pan.

Work area lighting

SterilGARD's lighting system produces 100 foot candles of illumination at the work surface area. The fluorescent light is externally mounted to

minimize heat buildup. The unit uses two common F32T8 fluorescent bulbs.

Drain Pan Cleanability

The drain pan is designed with 7/16" radius in all four bottom corners to facilitate cleaning. The worksurface supports have been designed to be removable for easy cleaning and to allow clear unobstructed access to the whole drain pan area during the cleaning procedure.

Air balance adjustments

Air balancing can be done by either of the following methods. However, it should be done only by a technician with proper training and equipment. (See Section 4, "On-Site Checks and Maintenance Procedures.")

- A speed controller adjusts for voltage differences and filter loading.
- An adjustable internal damper compensates for supply and intake imbalance due to pressure resistance drop differences of supply and exhaust filters if they are changed at a later date.

Easy filter access

For convenience and ease of service, the downflow and exhaust HEPA filters are installed and removed through the front of the cabinet without entry into SterilGARD's work area. This is particularly helpful if the cabinet is connected to an exhaust duct. Filters should be replaced by qualified technicians only.

Telescoping stand with adjustable feet. (optional)

The optional support stand provides the following range of heights:

Stand w/ adjustable feet	Knee Space Height	Work Surface Height	Overall Height
Minimum Setting	28 1/8"	30 1/8"	91 1/4"
Maximum Setting	36 5/8 "	38 5/8 "	99 3/4"

The stand is shipped disassembled, providing a smaller package for shipping, handling and installation. The stand is easily assembled and attached on site to support the cabinet.

Instructions on assembling and installing the stand are packed in the cardboard box with the stand.

The stand may also come equipped with an optional adjustable footrest.

Telescoping stand with castors. (optional)

The optional support stand with castors provides the following range of heights:

Stand w/castors	Knee Space Height	Work Surface Height	Overall Height
Minimum Setting	28 "	30 "	91 1/8"
Maximum Setting	34 "	36 "	97 1/8"

The stand is also shipped disassembled, providing a smaller package for shipping, handling and installation. The stand is easily assembled and attached on site to support the cabinet.

Instructions on assembling and installing the stand are packed in the cardboard box with the stand.

Solid-state electronic ballast

The SterilGARD®III Advance° features solid-state electronic ballasts for fluorescent and (optional) UV light. These ballasts increase reliability, efficiency, service life and reduce heat.

New Advanced Control Board

The SterilGARD®III Advance° is equipped with a new control board with enhanced reliability and diagnostic capability. The new board is designed to have built in immunity to momentary voltage interruption (flicker), electrical noise, and vibration. Diagnostic indicators provide easier troubleshooting of critical components without the need of special instruments.

UniPressure Plenum

The telescoping all steel positive pressure plenum in the SterilGARD®III Advance° provides the user with a number of desirable features which enhance

safety and reliability while reducing down time during servicing:

1. This unique plenum design directs air across then through the HEPA downflow filter, improving downflow uniformity, extending filter life and reducing noise.
2. The two piece plenum serves as the filter sealing mechanism providing a continuous and evenly distributed clamping force around the complete perimeter of the filters. This approach eliminates potential filter frame damage as experienced with typical approaches, which utilize point forces. This method assures secure and sealed filters.
3. The filter plenum has a gasketed surface to the upstream side of the filter. The gasket on both upstream and downstream filter frames reduces the transmission of vibration through the unit from the motor blower assembly.
4. The motor blower assembly is mounted on a slide plate, which forms one wall of the plenum. This plate is removed by loosening one screw and disconnecting an electrical plug connector.
5. The two telescoping sections of the plenum are operated by turning two threaded rods in each section. These screw clamps exert a force on the all-metal plenums, which distributes the clamping force uniformly to the filter frames.

Specifications

Weight

The weight of the SterilGARD®III, Model SG403A/ SG603A cabinet is 532/727 pounds with a shipping weight of 652/872 pounds. With the (optional) channel stand, the cabinet weight is 608/810 pounds with a shipping weight of 728/955 pounds.

Electrical Specifications

115 VAC, 1 Phase, 60 Hz

The SterilGARD®III Advance° incorporates Baker's StediVOLT® motor speed controller for the blower motor. This compensates for variations in incoming line voltages.

The SterilGARD®III features one GCFI protected circuit with two receptacles controlled by an internal self-resetting circuit breaker. The unit is furnished with one 16' power cord with 20-amp plug, type NEMA 5-20P. The power cord provides the cabinet and internal receptacles with a protective earth ground and serves as the units disconnect device.

The unit is protected with a 20 amp, 250 VAC circuit breaker.

	SG403A	SG603A
Blower motor (1,625 RPM)	6.6	10.9 amps
Fluorescent Light (ballast)	0.6	0.6 amps
Duplex outlets (G.F.I.)	5.0	4.0 amps
Control Circuit	0.4	0.4 amps
UV Light (optional)	0.9	0.9 amps
Auto Lift (optional)	2.0	2.0 amps

Environmental Conditions

The SterilGARD®III Advance° is designed to be used under the following conditions:

- Indoor use
- Altitudes up to 2000 meters
- Temperature range from 5° C to 40° C
- Main supply voltage fluctuations not to exceed ±10% of the nominal voltage
- Maximum relative humidity 80 percent for temperatures up to 31 degrees Celsius decreasing linearly to 50 percent relative humidity at 40 degrees Celsius.
- Transient overvoltages according to Installation Categories (OVERVOLTAGE CATEGORIES) I, II AND III (see Annex J). For Mains supply the minimum and normal category is II.
- POLLUTION DEGREE 2

II - PREPARING THE STERILGARD®III ADVANCE^o FOR USE

Checking the Cabinet Upon Arrival

Upon receipt of your new SterilGARD®III cabinet, first inspect the exterior of the crate, box and/or skid. If there is any broken glass or other visible damage, that fact should be noted on the receiving slip and immediately reported to the delivering carrier.

Next, remove the packing material and inspect the cabinet itself. Remove the cabinet from the skid with a forklift or other available equipment. If any concealed damage is found it should be reported to the delivering carrier. A claim for restitution should be filed within 15 days.

Due to the risk of mishandling by trucking companies, Baker has removed certain parts of the cabinet and has packed them separately. These items are listed on the packing slip, which accompanies the unit. Please check the packing slip carefully to be sure that all items have been located.

The Uses of a Biological Safety Cabinet

The SterilGARD®III Advance^o has been designed to provide a work area which protects the experiment from the environment, and the environment and operator from the experiment. The laminar flow biological safety cabinet is designed for work with Biosafety Levels 1, 2 and 3 (low to moderate risk) agents as listed in The Center for Disease Control's "Biosafety in Microbiological and Biomedical Laboratories" (U.S. Department of Health and Human Services, Public Health Service, Centers for Disease Control and National Institutes of Health, U.S. Government Printing Office, Washington, D.C. 20402. (HHS publication number CDC 93-8395).

Biosafety level 4 or extremely high risk agents should *never* be used in this cabinet, except in conjunction with a one-piece positive pressure personnel suit ventilated by a life support system within a high containment facility. Please consult your safety professional for a proper risk assessment.

CAUTIONS:

- * *The use of any hazardous material in the cabinet requires that it be monitored by an industrial hygienist, safety officer, or other qualified individual.*
- * *Explosive or flammable substances should never be used in the cabinet unless a qualified safety professional has evaluated the risk.*
- * *If hazardous biological work is to be performed, apply the enclosed biohazard decal. This is in accord with OSHA regulations (volume 39, number 125, Part II).*
- * *If chemical, radiological or other non-microbiological hazards are present, be sure to employ appropriate protective measures. Call upon a suitably trained individual to monitor the operation.*

Location Within the Laboratory

The ideal location for any biological safety cabinet is in a dead-end corner of the laboratory away from personnel traffic, vents, doors, windows and any other sources of disruptive air currents. Published research from The Baker Company and unpublished tests performed at the National Cancer Institute show that if a draft or other disruptive air current were to exceed the intake velocity of the cabinet, contamination can enter the work area or escape from it (for more information, contact The Baker Co). **Proper placement within the laboratory is essential.**

If the cabinet exhausts air into the laboratory instead of venting to the outside, it is important that there is adequate space between the top of the cabinet and the ceiling. A solid ceiling located too close to the exhaust filter will restrict the air and limit the intake velocity. The exhaust filter guard, an inverted "V" shaped perforated steel plate included with your SterilGARD®III cabinet, will provide the necessary distance between exhaust opening and ceiling. If the filter guard is not installed, the cabinet exhaust opening should be

no closer than 2³/₄" from the ceiling, to enable proper airflow. Consult with our Customer Service Department for the implications of this, and for alternatives.

Installing the Cabinet

Installation of this cabinet should be carried out in accordance with appropriate OSHA regulations and those of other regulatory agencies having jurisdiction.

1. Remove the protective container from around the cabinet.
2. Remove the strapping that holds the cabinet to the pallet.
3. Remove the tape that secures the viewscreen, work surface and diffuser.
4. The small cardboard box taped to the work surface contains the drain valve and the exhaust filter guard.
5. If cabinet exhausts its air directly into the laboratory instead of ducting it to the outside, install the exhaust filter guard on top of the exhaust damper using the two wing nuts installed on the damper.
6. The drain valve must be installed before the cabinet is either installed on the stand or placed on a counter top.
7. If ordered with the optional stand, refer to the stand installation and assembly instructions packed in the cardboard box with the stand.

NOTE: If you place your unit on the optional stand and you need to move the unit, we recommend you leave the unit on the stand. If you must take the unit off the stand to move it, disassemble the stand before moving it and reassemble at the new location.

Connecting the Exhaust

The SterilGARD®III cabinet can operate with filtered exhaust air entering directly into the room, or with filtered exhaust ducted to the outdoors. Details of these alternatives are as follows:

Exhaust into the room -

Never use the top of the cabinet or the work area for storage purposes, and never use flammable, explosive or toxic vapors or gases, or substances which generate them, unless a qualified safety professional has evaluated the risk. The filter removes only particulates and not gases, thus causing the recirculation of these within the cabinet.

Ensure that the exhaust filter guard is properly installed over the filter opening. The filter guard will provide the following advantages:

- Provide adequate space between filter opening and ceiling for proper airflow.
- Prevent potentially damaging objects from being dropped onto the filter.
- Prevent objects from being placed over the exhaust opening and reducing the exhaust flow rate.

Exhaust to the outside -

Whenever possible, the filtered exhaust should be canopy connected to its own separate exhaust system. If it must be channeled into a ganged exhaust system, make sure that the system is not a recirculating one.

The cabinet exhaust volume to the room for a STERILGARD III Model 403A and 603A are as follows:

MODEL	Sash Opening	Exhaust Volume
SG403A	8"	269 CFM ± 5%
SG403A	10"	335 CFM ± 5%
SG603A	8"	408 CFM ± 5%
SG603A	10"	510 CFM ± 5%

To facilitate connections to an in-house exhaust system, use one of the following:

The optional CEC (canopy exhaust connection) and HEC (hard exhaust connection) both mount directly over the exhaust filter, include an access panel for leak

checking the filter and terminate to a 10" diameter vertical collar which can be directly connected to standard duct work. We recommend an airtight damper on the (HEC), and a decon box and decon seal plate for the CEC to seal the cabinet for decontamination.

(CEC) CANOPY EXHAUST CONNECTION

Exhaust Connection Type	Sash Height	Exhaust flow rate (min/max) (CFM)	Suction Min/Max (" W.C.)
CEC403A	8"	322 / 520	0.05 / 0.25
CEC403A	10"	401 / 585	0.08 / 0.30
CEC603A	8"	490 / 754	0.15 / 0.40
CEC603A	10"	613 / 914	0.20 / 0.50

(HEC) HARD EXHAUST CONNECTION

MODEL	Sash Opening	Exhaust Volume	Suction
HEC403A	8"	269 CFM ± 5%	0.06" w.c.
HEC403A	10"	335 CFM ± 5%	0.08" w.c.
HEC603A	8"	408 CFM ± 5%	0.10" w.c.
HEC603A	10"	510 CFM ± 5%	0.15" w.c.

You may want to install an indicator light or some other safety device to give warning if the exhaust system fails. For more details, please contact The Baker Company.

While the cabinet contains an internal damper to adjust for variations in filter resistance and sash opening size, the building exhaust system should contain provisions to adjust the building system flow and pressure.

Final Connections and Tests

1. The plumbing connection to the service petcocks must be made with great care because the effluent from a safety cabinet may be biologically hazardous. When present, petcocks are piped within the cabinet. The external connection uses 3/8" compression fitting at the rear, top or bottom of the cabinet

outer sidewall seal panel. Connection to plant utilities should be made per NFPA by qualified personnel with proper materials and technique. *Flammable gas should not be piped into any cabinet.* However, if the risk is professionally evaluated and a decision is made to install a flammable gas petcock, then an emergency shut-off valve should be situated in an accessible location *outside* the cabinet.

2. A 20-amp power cord with a NEMA 5-20P plug is furnished with the SterilGARD®III. It should be plugged into an appropriate 115 Volt AC, 60 Hz, 20 amp dedicated utility outlet.
3. Thoroughly clean the interior of the cabinet. Locate sash at correct access opening height 8".
4. Press the blower switch. The yellow indicator below the switch should light and the blower should start.
5. Turn on the fluorescent light and make sure the bulb is lit. The lights will not go on unless the blower switch is on.
6. If your cabinet has been purchased with the optional Ultraviolet (UV) Light, lower the viewscreen to its fully-closed position and turn the UV light on to make sure it is operational. The UV light option features an interlock which prohibits its operation unless the viewscreen is completely closed and the fluorescent light is turned off.
7. Although all units are carefully tested at the factory, it is advisable that certain other checks are made on-site by a qualified technician after installation. These include testing the filters for leaks and checking the air balance of the unit, especially if it is connected to an exhaust system. A description of these tests can be found in Section 4, "On-site Checks and Maintenance."
8. It is also recommended that all personnel who will be using the cabinet study this Operator's Manual to learn how to use the cabinet most effectively. For additional start up and use procedures, please turn to Section 3, "Proper Cabinet Use."

III - PROPER CABINET USE

A biological safety cabinet is a valuable supplement to good sterile technique, but is not a replacement for it. If the cabinet is not understood and operated correctly, it will not provide an adequate protective barrier.

All activities that are to be performed in your cabinet should first be approved by a competent professional, such as an industrial hygienist or safety officer, to make sure that the cabinet is appropriate for the work it will be required to do. This person should monitor the cabinet and its operating personnel at regular intervals to see that it is being used correctly.

In order to keep the interior workspace clean and free of particulates, all Baker biosafety cabinets are designed for continuous operation. If the blower is turned off, the unit becomes contaminated with room air. Therefore it is recommended that the blower is left on at all times.

Operator Controls

The operator controls and indicators are arranged on the front panel of the unit. See Fig. 2 below. A number of switches are arranged in a single membrane switch assembly.

1 - Alarm Reset Switch/ Sash Level Alarm -

For normal operation, the viewscreen must be placed to allow an opening of 8" or 10". The sash alarm will be activated whenever the sash is raised or lowered from this level. To mute the audible alarm, press the alarm reset button. The indicator will continue to flash. After five minutes, the alarm will sound again to remind you to lower the viewscreen. You may press the alarm reset switch again to mute the alarm for another five minutes. *The alarm will sound again if the viewscreen is not in the proper position.*

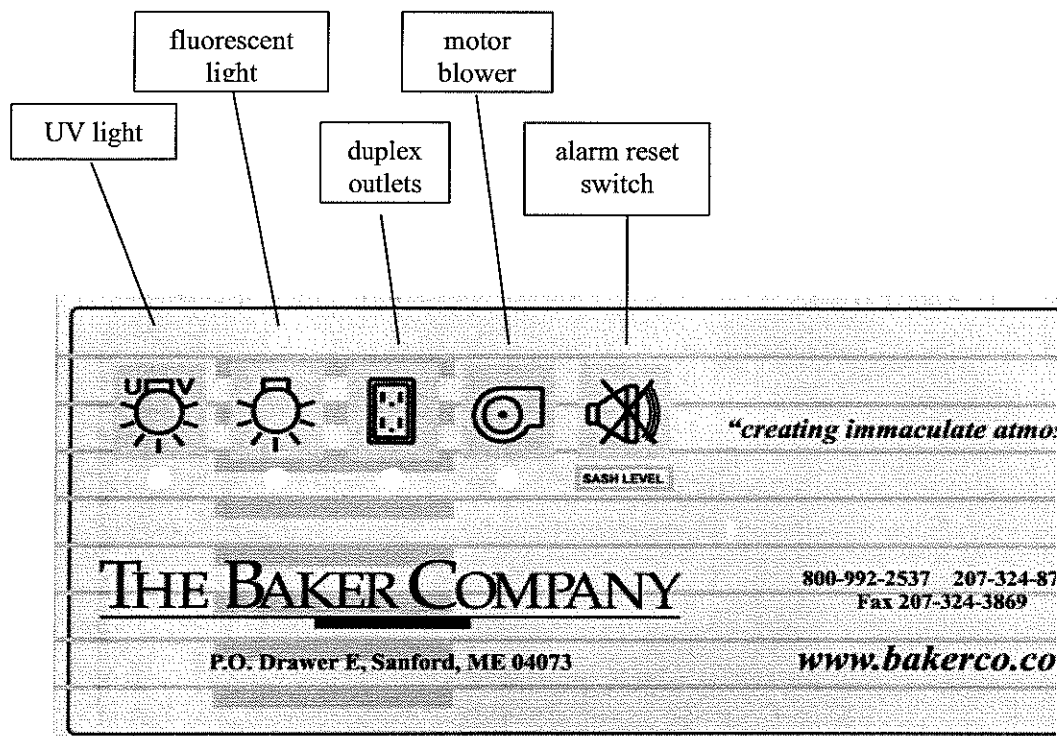

Fig. 2 Operator Controls

2 - Blower On/Off Switch -

This switch controls the power to the blower for the cabinet. When the switch is turned on, the yellow indicator light below the switch will light.

3 - Outlet On/Off -

This switch controls the outlets on both sides of the work area. When the outlets are turned on, the yellow indicator light below the switch will light.

4 - Light On/Off Switch -

This switch controls operation of the fluorescent light. **The blower must be turned on for the fluorescent light to operate.**

The yellow indicator light below the switch will light when the fluorescent light is turned on.

5 - Ultraviolet Light (optional) On/Off Switch

A bulb, which produces light in the ultraviolet (UV) range, may be used to help disinfect the work area. This switch controls the UV light inside the work area if the UV light is purchased and installed in the cabinet. **Before the UV light may be turned on, the viewscreen must be fully closed, and the fluorescent light must be turned off.** The UV light will shut off if the viewscreen is opened.

The yellow indicator light below the switch will light when the UV light is turned on. This unit is also capable of regulating the amount of time the UV light stays on which is determined by the operator. This function is very useful if the cabinet is to be left unattended for an extended period of time. To enable the timer, make sure the viewscreen is fully closed and the UV lamp is off. Depress the UV keypad switch and hold for 3 seconds. The alarm will pulse twice to signify that the timer mode has been entered. Release the switch. Immediately after, each press and release of the switch will program the timer to elapse one hour. (one pulse equals one hour, four pulses equals four hours, ect.) If no pulse is detected from the operator after four seconds, the timer begins to elapse automatically. The timer can be disabled at any time during or after the timing sequence by pressing the UV keypad or opening the viewscreen.

Ground Fault Interrupter

The outlets on this unit are protected by a ground fault circuit interrupter (GFCI). The GFCI is designed to protect the operator from a possible electrical hazard. If the GFCI detects a hazardous condition, it will cut off electricity to all of the outlets. The button in the center of the left hand outlet will pop out. To reset the GFCI, correct the cause of the problem, then press the reset button on the GFCI.

Start-up Procedure

1. If the unit has not been left running continuously, press the blower on/off switch. The yellow indicator light below the switch will light. Make sure that you have cabinet airflow by listening for blower sound. Check the reading on the mag gauge, it should be consistent with the last time the unit was on.
2. Turn on the fluorescent light. The fluorescent light will not operate unless the ultraviolet light is turned off.
3. Check to determine that the drain valve is in the closed position or the drain coupling is capped.
4. Wipe down the interior area of the cabinet with a surface disinfectant.
Note: Some disinfectants, such as bleach or iodine, may corrode or stain the steel surfaces. Good practice is to thoroughly clean the surfaces afterward with a detergent and rinse with sterile water to prevent corrosion.
5. Place all materials to be used for the next procedure inside the cabinet on the solid worksurface. **Disinfect the exterior of these materials prior to placing them on the worksurface.**

Everything required (and nothing more) should be placed in the cabinet before beginning your work so that nothing passes in or out through the air barrier, until the procedure is completed. Implements should be arranged in the cabinet's work area in logical order so that clean and dirty materials are segregated, preferably on opposite sides of the work area.

Blocking the front and rear perforated grilles must be avoided. If wipes or absorbent towels are used on the work surface, be sure to keep them away from the grilles.

6. After your equipment is in place inside the cabinet, adjust the sliding viewscreen so it is open no higher than the correct access opening height (8" or 10"). An alarm will signal if you are not at the cabinet design opening. This is important to maintain proper airflow.
7. After the cabinet has run for at least three minutes with the window in the proper position, you are ready to begin.

Working in the Cabinet Work Space

1. Hands and arms should be washed thoroughly with germicidal soap both before and after work in the cabinet. Operators are encouraged to wear long-sleeved gowns or lab coats with tight-fitting cuffs and sterile gloves. This minimizes the shedding of skin flora into the work area and protects hands and arms from contamination.
2. Perform all work on the depressed area of the solid work surface. Work with a limited number of slow movements. Since all of the equipment you need is already in the cabinet, it will not be necessary to move your arms in and out through the air barrier.
3. Because opening and closing doors in the laboratory causes air disturbance which might interfere with cabinet airflow, this kind of activity should be kept to a minimum while the cabinet is in use. Personnel should also avoid walking by the front of the cabinet while it is in use.
4. Avoid using floor-type pipette discard canisters. It is important that your used pipettes be discarded into a tray or other suitable container inside the cabinet. This reduces the temptation to move in and out of the work area unnecessarily.

Because of the restricted access, pipetting within the cabinet will require the use of pipetting aids.

5. Use good aseptic technique. Procedures done with good technique and proper cabinet methods will not require the use of a flame. If, however, a safety officer approves the use of flame after evaluating the circumstances, then a burner with a pilot light such as the "Touch-O-Matic" should be used. Place it at the rear of the work area where the air turbulence caused by the flame will have the least possible effect. Flame disturbs the unidirectional airstream and also contributes to the heat load. If the cabinet blower is unintentionally turned off, the flame could also damage a filter.

Tubing for a burner within the cabinet should be resistant to cracking or puncture. Material such as Tygon tubing is not acceptable for this use.

6. **Never operate your cabinet while the viewscreen alarm indicator is on.** The operating position of the sash provides an 8" or 10" high access opening, depending on the design set at the factory. This restricted opening permits optimum operating conditions for the cabinet. Because operators will not all be the same height, it is suggested that the operator use a chair which may be adjusted for height.
7. After a procedure has been completed, all equipment which has been in contact with the research agent should be enclosed, and the entire surface decontaminated. Trays of discarded pipettes and glassware should be covered. The cabinet should then be allowed to run for at least three minutes with no activity so that the airborne contaminants will be purged from the work area. Next, make sure that all equipment is removed from the cabinet.
8. After you have removed all materials, culture apparatus, etc., decontamination of the interior surfaces should be repeated. Check the work area carefully for spilled or splashed nutrient which might support bacterial growth. **Never use the cabinet to store supplies or laboratory equipment.**
9. We recommend that the cabinet be left running continuously to ensure containment

and cleanliness. If the user elects to turn the cabinet off at the end of a work session, the window should be closed completely. The sash alarm will be silenced when the window is in the closed position.

Reacting to Spills

Consult your safety professional for proper procedures and treatment of the specific agents you plan to use.

Ultraviolet Germicidal Lamp (optional)

The SterilGARD®III Advance^o is available with an ultraviolet light. The light is controlled by an on/off switch on the front panel. See Fig. 2. **The UV light will not operate unless the viewscreen is completely down, and the fluorescent light is off.**

Warning!

- *Do not defeat interlock, UV is hazardous!*
- *Eyes and skin should not be exposed to direct ultraviolet light.*
- *Ultraviolet light should not be relied upon as the sole decontaminating agent. Additional surface disinfection should be performed both before and after every cabinet use.*
- *A biological safety cabinet acts as a supplement to good aseptic practices, not as a replacement.*

Ultraviolet lamps lose their effectiveness over time and should be replaced when intensity drops below 40 microwatts per cm² at the worksurface. Check regularly.

Decontamination

Whenever maintenance, service or repairs are needed in a contaminated area of your cabinet, the cabinet must first be decontaminated by an

appropriate agent. The National Institute of Health, National Cancer Institute and the Centers for Disease Control have all recommended the use of formaldehyde gas for most microbiological agents. Its application requires individuals who are experienced in the decontamination of cabinets, since the gas itself is toxic.

A good reference for this procedure is NSF/ANSI Standard 49-2002 ANNEX G "Recommended Microbiological decontamination Procedure", NSF International, 789 North Dixboro Road, P.O. Box 130140, Ann Arbor, Michigan 48113-0140.

Whatever gas you choose, have the proper safety equipment (gas masks, protective clothing, etc.) within easy reach. In addition, you will want to be sure that the gas you are using will be effective against all of the biological agents within the cabinet. When you have decided which gas to use, post the antidote to it in a visible and nearby location. The volume of the SG403A & SG603A cabinets are 49 and 78 cubic feet respectively. Provide the correct amount of decontaminating gas for this volume.

Carcinogens and other toxins present a unique chemical deactivation problem and the standard biological decontamination will not, of course, be effective against chemicals or other non-biological materials. With materials of this kind, consult a qualified safety professional.

FOR MORE INFORMATION

For a complete listing of articles, papers and reports related to containment, clean air products and safety, contact The Baker Company for our complete Bibliography or visit our website at www.bakerco.com.

Decontamination procedure

Warning!

This procedure should be performed by qualified technicians only.

1. Surface-disinfect the inside of the window and all other surfaces on the view screen assembly.
2. Multiply the total volume of the cabinet (30 ft³ by .3 gram/ft³) to determine the amount of paraformaldehyde required to decontaminate the cabinet. If the cabinet is vented to the outside you must consider the volume of the duct work in the paraformaldehyde calculation.
3. Prior to sealing up the cabinet make sure all gas or flammable petcocks are closed and pressure tight. Use a soap bubble solution to make sure there is no leakage. Note you are creating a confined space.
4. The inside cabinet work space should be at room temperature with 60% to 85% relative humidity. If relative humidity is low (10 to 30%) add boiling water in the work space. If it is (40% to 55%) add a pan of hot tap water in the work space. Relatively humidity above 85% will require extra clean up which will be covered in step 15.
Note: Without the proper relative humidity the formaldehyde gas will not be effective. The mode of entry of formaldehyde into the living organisms is through the cell wall by the absorption of water.
5. Place a heating mantle with paraformaldehyde in the work space. The heating mantle must be able to reach 450 degrees F and must have a grounded plug which should be plugged in to an outlet outside the cabinet.
6. This step is optional. Place a second heating mantle in the cabinet with 10% more by weight of ammonium bicarbonate than paraformaldehyde. This will be used later in step 13 to neutralize the formaldehyde gas.
7. This step is recommended. Place spore strips inside the cabinet to confirm the decontamination process has been successful.
8. If the cabinet is vented to the room, use a sheet of plastic and seal the front access and exhaust port openings. These openings should be sealed such that the exhaust airflow recirculates back to the front access opening. This will promote the even distribution of formaldehyde gas throughout the cabinet.
9. If the cabinet is vented to the outside, then the exhaust transition should have a means to recirculate the exhaust airflow back to the cabinet blower. This will promote the even distribution of formaldehyde gas through the exhaust filter. Seal the front access opening.
10. Turn on the heating mantle containing the paraformaldehyde flakes.
11. After 25% of the paraformaldehyde has depolymerized, turn on the cabinet blower for 10 to 15 seconds. Repeat after 50%, 75% and 100% of the paraformaldehyde has depolymerized.
12. Allow the formaldehyde gas a minimum residence time of 12 hours, preferably over night.
13. Turn on the heating mantle containing ammonium bicarbonate (NH₄HCO₃) and the cabinet blower and allow the two gases to circulate for at least one hour. Then vent the cabinet to the outside.
14. Aseptically remove spore strip and place in Trypticase-soy broth and incubate for 7 days. No growth will verify the decontamination process.
15. When cleaning up, you may find residual paraformaldehyde (white powder) on the metal or glass surfaces. To remove this, use ammonia in warm water, wear gloves and wipe down the affected surfaces. The paraformaldehyde will dissolve in water and be neutralized by the ammonia.

Cleaning and Disinfecting Stainless Steel

Simple Cleaning

Caution

Do not use steel wool or steel pads when cleaning stainless steel.

Dirt deposits on stainless steel (dust, dirt and finger marks) can easily be removed. Frequently, warm water, with or without detergent, is sufficient. If this does not remove the deposits, mild, non-abrasive household cleaners can be used with warm water and bristle brushes, sponges or clean cloths.

Iron rust discoloration can be treated by rubbing the surface with a solution of 15% to 20% by volume of Nitric Acid and water and letting it stand for one to two minutes to loosen the rust.

Disinfection

The purpose of disinfection is to destroy particular organisms that could pose a potential hazard to humans or compromise the integrity of the experiment. It is important to use a suitable disinfectant in the concentration appropriate to the organism being killed. Standard disinfectants include: Hypochloride (chlorine bleach), Iodophor-Detergent, Ethanol, and Phenol .

Important

Disinfection and cleaning should always be followed by rinsing in clean hot water and wiping the surface completely dry.

Disinfect the work surface before and after every procedure.

1. Disinfect surfaces of all equipment used.
2. Remove all items from the inside of the cabinet.
3. Place all items that may have come in contact with the agent(s), such as used pipettes, in a biohazard bag or other suitable container.

4. Disinfect the entire inside surface of the cabinet.

For additional information on cleaning and disinfecting stainless steel, please refer to: "Decontamination, Sterilization, Disinfection, and Antisepsis", Vesley, Donald and Lauer, James L., *Laboratory Safety Principles and Practices, Second Edition*, 1995, Fleming, D.O., Richardson, J.H., Tulis, J.J. and Vesley, D., editors, ASM Press, Washington, D.C., pp. 219-237; and *Biosafety Reference Manual, Second Edition*, 1995, Heinsohn, P.A., Jacobs, R.R. and Concoby, B.A., editors, AIHA Publications, pp.101-110.

Using Ancillary Equipment

The rule to keep in mind is that the more equipment placed in the cabinet, the greater will be the air turbulence it causes. The turbulence resulting from equipment and materials can disrupt the designed airflow and reduce the effectiveness of the cabinet. When you use equipment which rotates, vibrates or heats, be sure to place it at the rear of the work area if possible. This will minimize the turbulence at the access opening.

About the HEPA Filters

The High Efficiency Particulate Air (HEPA) filter is one of the essential components of a biological safety cabinet. It is the shield, which stands between the operator and environment and the experimental agent.

The HEPA filter consists of a continuous sheet of glass fibers that are pleated and then mounted in a rigid frame. It is very delicate and the filter media should *never* be touched.

Proven efficiency in all HEPA filters used in Baker cabinets is 99.99% for particles 0.3 microns in diameter. The 0.3 micron particle is used as the basis for filter definition because theoretical studies have shown that filtration efficiency should be at a minimum for particles of this diameter, with efficiency increasing for particles either larger or smaller. Experiments with various viruses and microbial agents have proven the effectiveness of HEPA filters. (Contact The Baker Company for more information).

It must be pointed out that the HEPA filter is *does not* filter gasses or vapors, nor are they 100% efficient on particulates. Consider the filters' inefficiency when performing a risk assessment. Since this cabinet is partially recirculating, there will be gaseous buildup to the point of equilibrium if these agents are used.

The life of a filter is determined by the cabinet/motor/blower system design, how it is used and how often. Under normal laboratory conditions, you can expect at least five years of use. However, misuse or a heavy dust load within the cabinet will shorten any filter's lifetime. Bunsen burners and misuse of chemicals will also shorten the useful life.

- Work only with agents assigned to biosafety levels 1, 2, or 3 in this cabinet.
- Always close the drain valve after each use.
- If the unit presents a warning signal, don't operate the unit until cause is determined and the warning ceases.

If the operators are well trained and use good common sense when operating your cabinet, you should have very few problems.

Operating procedures

After many years of seeing our equipment used and misused, we have made up this list of suggestions:

- Store equipment and supplies outside of the cabinet.
- Always leave the blower on.
- Set the view screen at the proper height.
- When possible, use pipetting aids.
- Avoid use of an open flame within the cabinet unless the use has been specifically approved by a safety professional.
- Always keep the air intake grilles clear and unobstructed.
- Only use toxic, explosive or flammable substances if a safety professional has approved them for work in your cabinet.
- The control system will adjust automatically for small changes in the load on the blower. Adjustments for larger changes should only be made by a qualified technician. Don't change the cabinet or blower speed unless the change is required by a decrease in measured air velocity.

IV - ON-SITE CHECKS AND MAINTENANCE PROCEDURES

We recommend that the following checks be performed before initial use, after relocation, and after each filter change. They should also be carried out at regular intervals, usually six months or one year, as specified by an industrial hygienist, safety officer or other qualified person. The tests described below meet recommended minimum requirements and only experienced technicians using proper procedures and instruments must perform them. Our representatives can tell you about other tests, which you may consider desirable.

As reported earlier in this manual, each individual cabinet made by The Baker Company is carefully tested before it leaves the factory. Your copy of the test report, which you will find at the back of this manual, gives the factory test results for your own SterilGARD®III cabinet. Use it as your record of the original testing, and as your guide to testing in the future. To gain many years of satisfactory service, please be sure that your maintenance personnel come as close as possible to duplicating these original test figures.

Your test procedures should be identical to ours so that achieving similar test results and comparison of data will be possible. Please correspond directly with us to request detailed procedures for your particular cabinet model. Alternate testing procedures can be found in the NSF International Standard No. 49.

The Airflow Balance

Warning!
This procedure should be performed by qualified technicians only.

The airflow balance, which is set at the factory, provides your cabinet with the proper air volume and velocity control to minimize leakage of airborne contamination either into or out of the work area.

In order to duplicate as closely as possible the airflow characteristics described in the original factory test report, please follow these steps:

1. Adjust the window to its designed opening height. If the window is set above or below this height an alarm will sound.

2. Intake Velocity

Specific details for acquiring the intake velocity readings are illustrated on the cabinet instruction label affixed to the front of your cabinet. There are two methods that can be used to obtain the correct intake velocity readings on your SterilGard III Cabinet. The "Primary Method" is the recommended method where a direct inflow measurement or "DIM" is sealed directly to the front access opening to acquire the cabinet airflow rate. If the Primary Method cannot be used due to the absence of a DIM or minimal work space, the "Secondary Method" must be used. This method is completed by lowering the window sash opening to three inches and using a thermal anemometer to take a set of readings across the reduced opening. The average of these readings is then used to calculate the actual intake velocity of your SterilGard Cabinet as shown in the example below.

(Ex. SterilGard 403A)

$$\begin{array}{r}
 \text{3" Window Opening Area} \quad \text{Correction Factor} \\
 \begin{array}{c}
 \text{(3" SASH)} \\
 \text{Traverse Vel. X} \\
 \text{Avg.}
 \end{array}
 \times
 \frac{0.958 \text{ FT}^2(0.089\text{m})^2}{2.56 \text{ FT}^2(0.237\text{m})^2}
 +10 \text{ FPM} \\
 \text{8" Window Opening Area} \quad \quad \quad (0.05)\text{M/S}
 \end{array}$$

Finally, a correction factor is added to this value (SG403A + 10 FPM) (SG603A + 5 FPM) which again is noted on the airflow data plate affixed to the front of your cabinet.

3. Down flow Velocity

NOTE: The IV bar and UV light bulb need to be removed while performing downflow readings.

Your SterilGard III Biological Safety Cabinet has been NSF International certified with a dual down flow velocity listing. Your cabinet was tested at the factory using a non-uniform or "zoned" grid pattern (21 readings) to reduce the number of readings needed to achieve the set point. Specific details of this pattern and values are illustrated on the cabinet instruction label affixed to the front of your cabinet. The second listing, which is the down flow range, is 50 to 60 fpm (feet per minute) for both 8" and 10" access opening heights can also be used. Refer to NSF /ANSI 49-2004 under "Annex F 2.3.1 Uniform Down Flow Cabinets" to obtain detailed instructions.

4. Compare your results with those originally recorded at the factory.

Warning!

When the light canopy is lowered, some electrical parts are exposed. Do not perform any work inside the canopy unless you are a trained electrician or electronic technician.

5. Make adjustments to the blower speed controller and the damper as necessary. The speed controller is located inside the light canopy on the far left side. Turn the screw clockwise/ counterclockwise to increase/decrease flow. The damper is located inside the cabinet. An adjustment rod with indicator is positioned at the top of the cabinet on the left side. Using a proper wrench the damper can be opened/closed by turning the rod clockwise/counter clockwise to increase/ decrease flow. The chart below may aid with making the correct adjustment:

Condition		Adjustment	
Downflow	Inflow	Damper	Speed Controller
High	High		Decrease
Low	Low		Increase
Low	High	Close	
High	Low	Open	
OK	Low	Open	Increase
OK	High	Close	Decrease
Low	OK	Close	Increase
High	OK	Open	Decrease

NOTE: As the HEPA filters load up with particulates, airflow will be maintained automatically, at least until the filter resistance increases 60%. When airflow eventually diminishes, you will have to increase the blower speed in order to maintain the original volume of total airflow. There is a speed control located in the light canopy on the far left side. Turn it clockwise until you have the desired airflow. If the airflow cannot be maintained, it will be necessary to replace the HEPA filters. (See "Procedure for HEPA Filter Replacement" later in this section).

Filter Leak Test

The filters in your cabinet were tested at our factory before shipment to ensure that the media, gasket, and frame were not exceeding NSF International Standard 49 allowable leak rates. Since filters may become damaged in transport, we recommend that the filters be re-tested by qualified technicians before the cabinet is used. The filters should also be leak tested at prescribed intervals as specified by an industrial hygienist, safety officer or other qualified person. NSF International details the steps for performing the filter leak test in their Standard 49.

Filter leak test procedures:

1. Remove diffuser under downflow filter and external damper over the exhaust filter to access filter media and frame.
2. Perform calculations/measurements for upstream concentration of aerosol challenge.

Warning!

Decontaminate the unit before measuring the upstream concentration of aerosol in a contaminated plenum.

3. Perform filter leak test per NSF 49.
4. Repair leaks as required.

Airflow Smoke Pattern Test

We recommend that qualified technicians verify the direction of airflow within your cabinet before the cabinet is used. The direction of airflow should also be verified at prescribed intervals as specified by an industrial hygienist, safety officer or other qualified person. NSF International details the steps for performing the airflow smoke pattern test in their Standard 49.

Cabinet Integrity Test

The sealing integrity of your cabinet was tested at our factory before shipment to ensure that the welds, gasketed seams, and hardware were free of detectable leaks. Since these items may become damaged in transport, we recommend that they be re-tested, by qualified technicians, before the cabinet is used. The cabinet integrity test should also be performed at installation, relocation and at prescribed intervals as specified by an industrial hygienist, safety officer or other qualified person. NSF International details the steps for performing the cabinet integrity test in their Standard 49.

Cabinet Integrity Test Procedure:

1. Decontaminate the cabinet if it has been used.
2. Disconnect cabinet from electrical source.
3. Shut off all gas, air, and/or vacuum ports.
4. Seal off the exhaust opening by taping around the external damper and the slot, or by taping a piece of cardboard or plastic over the opening. If the cabinet is connected to an external exhaust, close the gas tight damper or remove ductwork to allow sealing.
5. Remove the light canopy, the electrical panel, and the window tracks.

6. Seal the front window opening by taping a piece of heavy gauge plastic around the perimeter of the opening.

Warning!

Decontaminate the unit before pressurizing, if it has contaminated plenums.

7. Perform cabinet integrity test per NSF 49.
8. Repair leaks, as necessary.
9. Restore the cabinet to operating status. Be sure to remove the sealing material, clean the cabinet, and reassemble all components.

Electrical Safety Tests

The electrical leakage, ground circuit resistance, and polarity were tested at our factory before shipment to ensure that there is no risk of electrical shock present in your cabinet. Since electrical components may become damaged in transport, we recommend qualified technicians retest them, before the cabinet is used. The electrical safety tests should also be performed at prescribed intervals as specified by an industrial hygienist, safety officer or other qualified person. NSF International details the steps for performing these tests in their Standard 49.

Note: While performing the electrical safety tests, ensure that the connections with the test leads are solid, as poor connections will increase the resistance reading. Also, ensure that the exposed metal being touched is solidly connected to the cabinet frame. Gasketed panels may not provide a reliable measurement.

Maintenance Notes

Cleaning the Work Area

Spills that fall through the perforated grilles can be removed through the drain valve after proper decontamination.

To wash the drain pan under the work surface, lift up and surface decontaminate the solid work surface, the perforated grille, and remove the work surface supports. This provides

unobstructed access to the drain pan for easy cleaning. Remember that this area must be assumed to have contamination, so use caution in the way you approach the task. Make sure you close the drain valve when you are finished cleaning the drain pan.

Ultraviolet Germicidal Lamp (optional)

As reported in other sections of this manual, UV germicidal lamps lose their effectiveness over time and should be replaced when their intensity at the work surface drops below 40 microwatts per square centimeter at a wavelength of 253.5×10^{-9} meters.

If your cabinet has a germicidal lamp, frequently measure its intensity at the geometric center of the work surface with an ultraviolet light meter. The appearance does not indicate UV effectiveness.

Check the Mag Gauge Or Optional Air Flow Monitor (AFM) Regularly

Changes in areas surrounding the laboratory may produce unexpected dust or other conditions which affect the filters. To maintain filter integrity and good cabinet operation, check the Mag Gauge or AFM periodically.

Replacing the HEPA Filters

If the control system presents an alarm, or if your periodic checks of total airflow show a drop of ten percent or more from the original settings, the filters may be loading with particulates. As explained earlier in this section, the blower speed can be manually increased to compensate for filter loading. However, when the airflow can no longer be maintained or when the filters are damaged, they need to be replaced.

Before any seal panels are removed, the cabinet should be decontaminated. Please see pages 11-12 for specifics on decontamination. The filters are sure to have collected microorganisms and other potentially harmful particles generated in the work area during their lifetime, and maintenance personnel should not allow

themselves to be exposed. It should also be remembered that a specific gaseous decontamination may work against microorganisms, but not against chemical agents. Where chemicals are present, consult an industrial hygienist or other qualified person.

A chemically contaminated filter must be handled with caution. Clothing and/or breathing apparatus should be used to protect personnel as necessary to reduce the hazard. It is advisable to seal the contaminated side of the filter by taping a plastic sheet or cardboard over the face before removal. This should minimize the number of particles shaken loose from the filter. Once removed, the filter should immediately be sealed in a chemical hazard bag and then disposed of safely in accordance with environmental regulations.

After filter replacement has been completed, the cabinet and the room should be cleaned and decontaminated in a manner consistent with the nature of the hazardous material. The cleaning materials, along with the protective gear and clothing, should be properly disposed.

HEPA filters are very easily damaged, and you will want to use great care in handling so as to avoid injury to the filter media and gasket surfaces. When installing the new filters, it is a good idea to tape a piece of cardboard over the filter media to give protection against dropped wrenches or misdirected fingers. Of course, you'll need to make sure that the cardboard is removed before the access panels are re-installed. Inspect the filters carefully before and after installation. A broken or damaged filter is worthless.

For detailed instructions on changing the filters, see the following two sections.

Changing Filters

Warning!

Decontaminate the unit before changing filters and then disconnect power source.

1. Lower the sash to the fully closed position.
2. Disconnect the tygon tube from the back of the magnehelic gauge and lift off the outer closure panel.
3. Remove the canopy locking fasteners inside the inner closure panel and then lower the canopy. (Make sure cables are secure.)
4. Remove the inner closure panel by removing the two bolts at the top and loosening the two bolts at the bottom.
5. Loosen the four lock nuts holding the electrical mounting board and carefully place board face down inside canopy. (No electrical connections need to be removed)
6. Loosen each of the eight 3/8" hex head bolts on the front seal panel. Be sure not to damage or lose the seal washers on each bolt.
7. Remove the front seal panel making sure that you do not damage the gasket. The filters are now exposed.
8. Loosen the 1/2 - 13-plenum clamp bolts, located on each side of the downflow plenum, approximately 3 1/2 revolutions or until the supply plenum is raised about 1/4 inch above the filter. See Figure 3.
9. Loosen the filter gasket seal from the metal plenum. A putty knife works fine to break the gasket seal if necessary. Align the downflow filter with the notches in the frame of the plenum and remove the filter by sliding it towards you.

NOTE: *Once removed, the filters should immediately be sealed in a chemical hazard bag appropriately marked for the type of hazard and then disposed of safely in accordance with environmental regulations. If you are not removing the exhaust filter, proceed to step number 11. If only the exhaust filter is to be changed, the downflow plenum clamp bolts (lower) should be loosened four or more revolutions before*

loosening the exhaust plenum clamp bolts (upper).

10. Alternately loosen the 1/2 - 13-plenum clamp bolt, located on each side of the exhaust plenum, approximately 3 1/2 revolutions or until the exhaust plenum is lowered about 1/4 inch. See Figure 3. Loosen the exhaust filter asket seal from the metal plenum. Remove the exhaust filter by sliding it towards you.

Next turn each bolt $1\frac{1}{4}$ to $2\frac{1}{2}$ revolutions

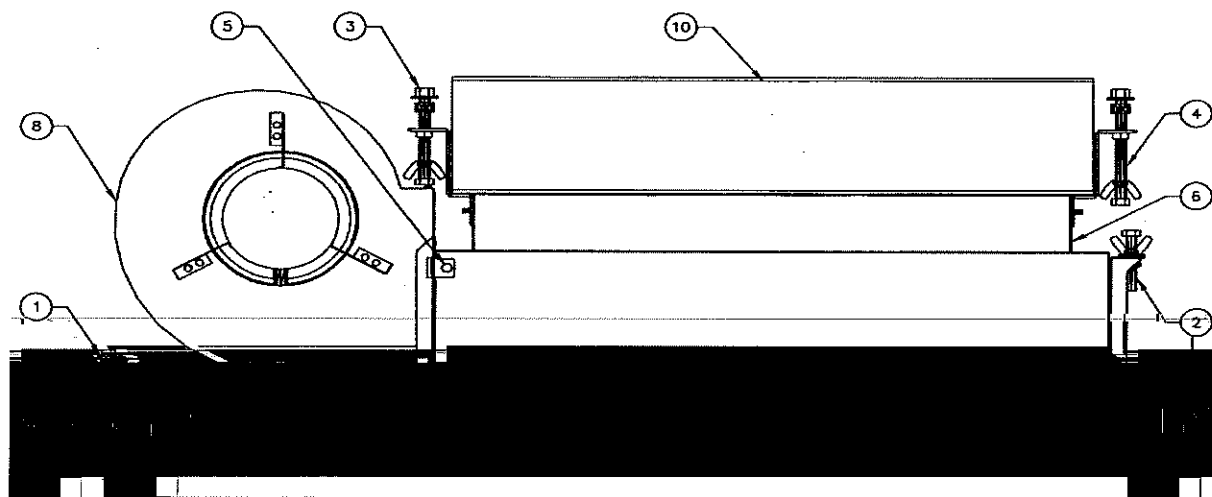

10	EXHAUST FILTER
9	SUPPLY FILTER
8	MOTOR BLOWER ASSEMBLY
7	SUPPLY PLENUM
6	EXHAUST PLENUM
5	MOTOR BLOWER ASSEMBLY CLAMPING BOLT
4	EXHAUST PLENUM ADJUSTING BOLT
3	EXHAUST PLENUM ADJUSTING BOLT
2	SUPPLY PLENUM ADJUSTING BOLT
1	SUPPLY PLENUM ADJUSTING BOLT
FIG NO. _____ DWG NO. 333166	

u
n
t
i
l
t
h
e
p
a
n
e
l
g
a
s
k
e
t

is evenly compressed to $\frac{1}{8}$ -inch thickness. Do not overtighten. (Do not use a power drive socket for this procedure).

Fig. 3 - Downflow Plenum

11. Replace the filter(s) by simply aligning them with the notches in the frame of the plenum and sliding them back against stops in rear, ensuring that the gasket remains attached on both sides.
12. The exhaust plenum clamps should be tightened first, alternately two to three revolutions at a time until the filter gasket is compressed to approximately $\frac{1}{8}$ inch.
13. The downflow plenum clamps can now be tightened, alternately two the three revolutions until the gasket is compressed to approximately $\frac{3}{16}$ inch.
14. Reinstall the front seal panel by first tightening each $\frac{1}{4}$ - 20 hex cap screw until the bolt seal washer is engaged with the panel.

Troubleshooting

Here are some suggestions based on our experience with the use and misuse of biological safety cabinets.

When a smoke test indicates that there is air flowing from the interior of your cabinet into the surrounding room -

1. Make sure that the exhaust damper is adjusted to its factory-marked position and that no other objects are blocking the airflow.
2. Make sure that the stainless steel downflow diffuser is installed in the work area under the downflow HEPA filter.
3. If your cabinet is connected to an in-house exhaust, make sure that there is adequate exhaust suction and the system is not producing back pressure. Also, be sure the dampers are open. Re-balance the exhaust system to handle an adequate volume of air and static pressure (suction). Consult with building maintenance people.
4. The exhaust filter may be loaded with dirt if the unit has been in service for some time. Decontaminate, and replace all HEPA filters.
5. There may be high cross-drafts in the room which are causing the outflow of smoke. Check the airflow balance, following the procedure recommended in an earlier section of this Section. Eliminate the source of the cross draft.

When there is low airflow within the work area and through the exhaust filter -

1. Check the incoming line voltage. Low voltage may cause the blower to operate at a slower-than-designed speed. Although this should be corrected in the building's electrical system, you may be able to compensate by adjusting the blower speed control clockwise until proper velocity is reached. The control is located on the left side of the light canopy.
2. Check the filters for damage. Decontaminate the unit and replace the filters, if necessary.

If there is no air flow within the work area -

1. Check to make sure the blower switch is turned on. The yellow indicator below the button should be lighted.
2. Check to make sure the unit is plugged into a dedicated electrical outlet (grounded 20 amp, 115 Volt AC, 60 Hz).
3. Check to make sure the wiring connections inside the left end of the light canopy are pushed together properly.
4. Check to see if the lights are working. If they are, then turn the blower switch off and let the cabinet set for ten minutes. This allows the motor time to reset itself, if it has been overheated.

Note: If the motor restarts and there is a whining sound, the motor bearings may be causing the motor to overheat.

5. If these solutions do not correct the problem, or if the blower failed to start after the rest period, then the speed control, blower motor, or capacitor is defective. A qualified electrician, using the wiring diagram in the Appendix of this manual, can by-pass the speed control to determine if it is defective.

If one (or both) of the electrical outlets does not function -

1. Check to make sure the outlet switch is in the on position. The yellow indicator below the switch should be on.
2. Check the reset button on the Ground Fault Interrupter outlet. If the GFI has tripped out, press the reset button.
3. The outlets are also protected by a self-resetting thermal circuit breaker. A qualified electrician, using the wiring diagram in the Appendix of this manual, can check this breaker.

If the ultraviolet light does not work -

1. Ensure that the window is completely closed and the fluorescent light is off.
2. Check for proper installation of the ultraviolet bulb in the lamp sockets.
3. Check the ultraviolet light bulb; replace if necessary.
4. Have a qualified electrician check the wiring and ballast for continuity. The wiring can be traced to the source of a break. If none of the above is effective, the ballast may need replacing.

When there is uneven fan operation, or noise from the motor/blower assembly -

CAUTION: It may be necessary to decontaminate the cabinet before performing any exterior panels.

1. Lower the light canopy from the unit and check the multi-pin connectors at each end to be sure they are securely engaged.
2. Check the speed controller.
3. Lower the light canopy from the unit and check the multi-pin connectors at each end to be sure they are securely engaged.
4. Check the blower wheel for contact with the blower housing.
5. Check the blower for loose objects.

When the window open alarm is sounding -

1. Check to ensure the window is at the correct position. The alarm should be silent when the window is at the proper design opening. The indicator below the alarm-reset button will flash. You may cancel the audible alarm for five minutes by pressing the alarm-reset button. The indicator will continue to flash until the window is set in the correct position. After 5 minutes, the alarm will sound again. You may press the alarm-reset button again.

If the fluorescent light does not work -

1. The blower switch should be turned on, and the yellow indicator below the switch should be lit.
2. Lower the light canopy from the unit and check the multi-pin connectors at each end to be sure they are securely engaged. If the lamp flickers and can be corrected by vigorous rubbing of the bulb, there is probably an improper ground. The wiring can be traced to the source of a break.

If the air magnehelic gauge has high or low readings -

A higher reading than what was originally stated on the cabinets test report could be an indication of the following:

1. Blocked or partially obstructed perforated grilles (front and/or rear).
2. Towels or wipes have blocked the towel guard on either the back or sides of the unit.
3. The viewscreen is in the closed position and the in-house exhaust fan is still pulling air through the cabinet.
4. Incorrect air flows

For any of the above conditions, always check for proper air flows first.

A lower reading than what was originally stated on the cabinets test report could be an indication of the following:

1. Partially or totally blocked filters.
2. Incorrect air flows.
3. Perforated grilles or worksurface has been removed.

For any of the above conditions, always check for proper air flows first.

SG403A/SG603A DISASSEMBLY INSTRUCTIONS

NOTES: Refer to diagram on Page 19 for blower, filter and plenum configuration.
For Motor/Blower removal, follow steps 1-18.
For filter removal, follow steps 1-15 & 21-23

TOOLS REQUIRED: (1) 3/8" Spin Wrench (2) 3/8" Socket and Drill (3) 3/4" Wrench and (4) 1/4" Spin Wrench

DISASSEMBLY:

Disconnect Power Source!

1. Remove front cover.
 - A. Lift out at the bottom enough to disconnect the magnehelic gauge hose.
 - B. Lift out at the bottom and carefully lift up and away from the unit.
2. Remove the thumb screws that retain the face frame to the canopy (located inside of the front cover frame).
NOTE: Lower the sash to the closed position.
3. Drop the canopy down on its restraint cables and disconnect the limit switch wires.
4. Disconnect the canopy wires from the circuit board on the right hand side of the canopy.
5. Remove cable from relay.
6. Disconnect the restraint cables from the face of the unit and lift off the canopy at the bottom.
7. Remove the two retaining bolts at the top of the unit that secure the "information center" panel.
8. Loosen the four retaining nuts on the outer edges of the breadboard panel that houses the electrical components.
9. Disconnect the cord assembly at the top of the unit that goes up from the breadboard assembly.
10. Disconnect plug on left side.
11. Lift off the whole breadboard assembly with the cord assembly attached, and store in a safe place.
12. Remove "information center" panel.
13. Remove the window by lifting up and out. Store in a safe place.
14. Using a 3/8" drive socket and drill, remove ten retaining bolts from the front access panel. Remove the center top bolt last.
15. Loosen the track retaining bolts and remove the tracks by sliding out horizontally.
16. Blower/motor removal - remove one bolt, lock-washer and clip at the forward edge of the supply plenum.
17. Disconnect the motor leads by pulling apart at each connection.
18. Remove the blower by sliding it out the front.
19. Raise the lower supply plenum approximately 1/4" so that the filter can slide out.
20. Remove the supply HEPA filter by sliding out of the front.
21. Loosen the exhaust filter plenum by adjusting the two wing nut retaining bolt assemblies.
NOTE: Pull towards you on the L.H. retaining bolt and away from you on the R. H. retaining bolt.
22. Lower the exhaust filter until it clears the front top edge of the unit.
NOTE: Break the exhaust HEPA seal by lifting up gently at both front corners.
23. Pull exhaust filter straight out towards you.
24. Loosen the bolts on the inside of the exhaust plenum enough to allow the clamping hardware to angle out away from the slotted retaining brackets.
25. Remove the side panels - (7) retaining bolts per side.
26. Remove the 3/4" brass nuts from each petcock plumbing connection.
27. Repeat the process on the other side, if plumbing exists.
28. Lift out the worksurface using the pulltabs near unit sidewalls.

REASSEMBLY:

Use the disassembly instructions in reverse order.

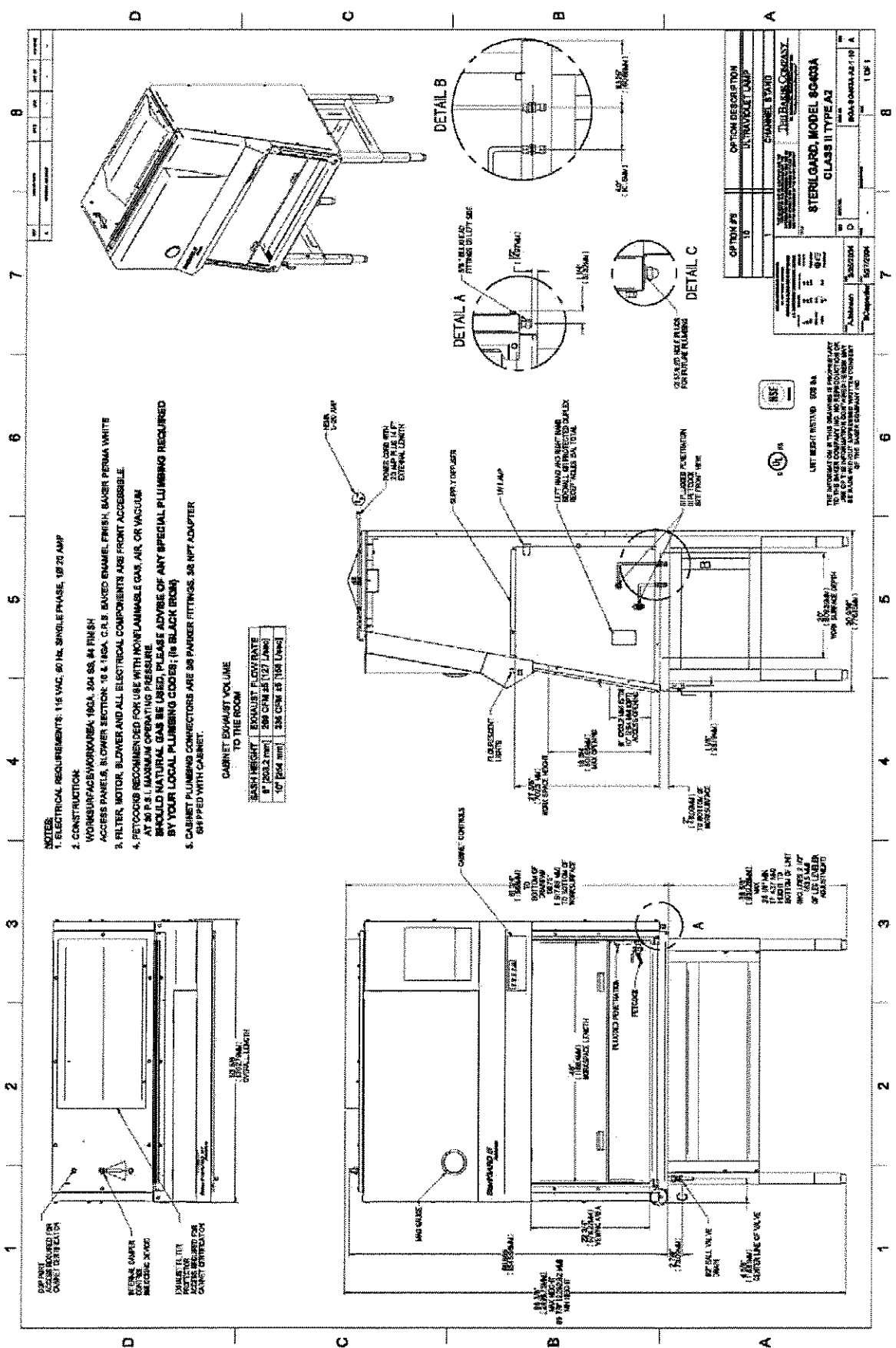

A	ORIGINAL RELEASE	DATE	DRN	APP BY	APP DATE
B	DEL 3006/UPDATE WIRING PER ECR00417	92804	TFM	APP BY	APP DATE

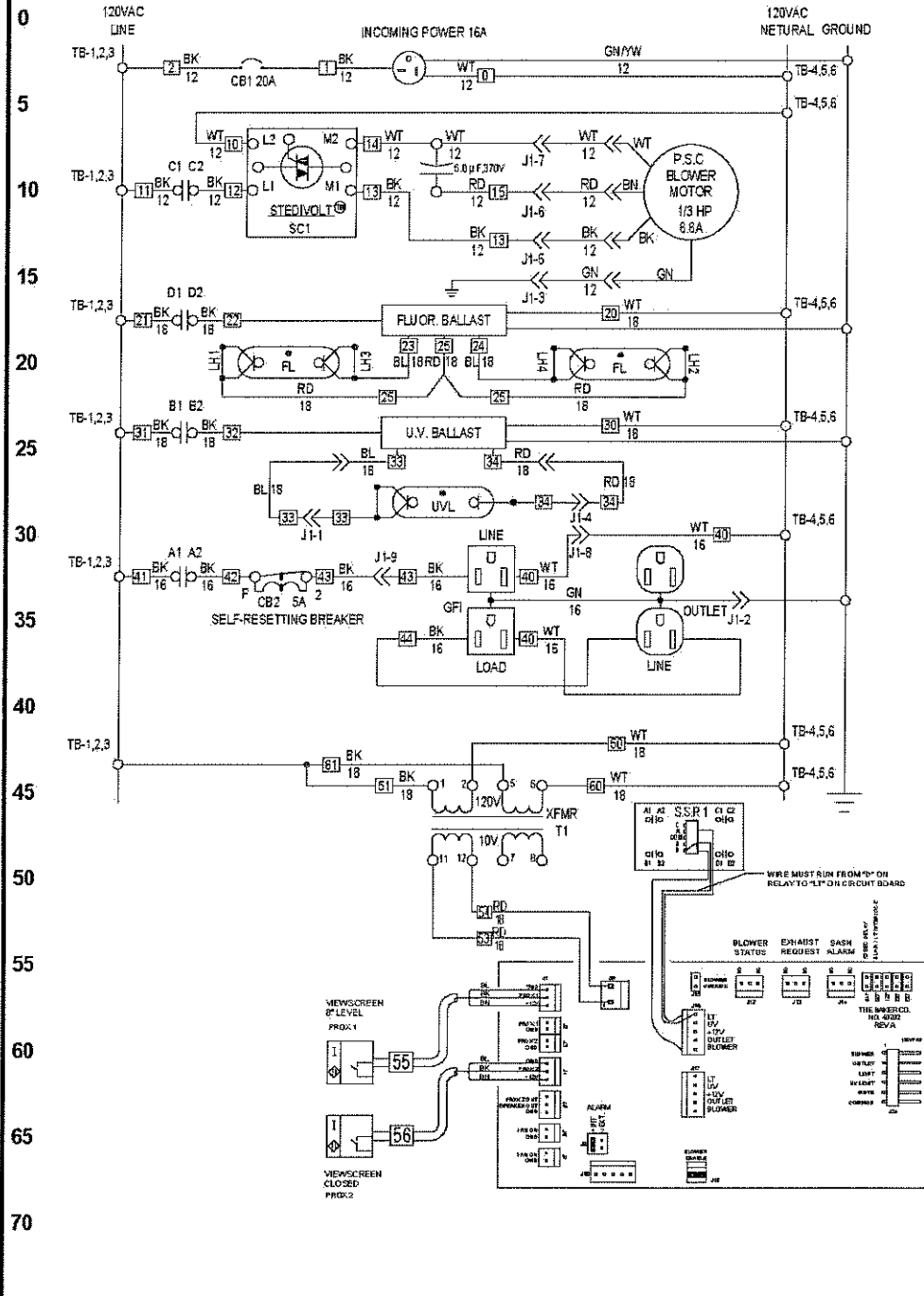

NEMA 5-20P PLUG	32897
CIRCUIT BREAKER	40449
J1, CANOPY LEFT POWER CONNECTOR	37843
TB, CANOPY TERMINAL BLOCK	40450
CAPACITOR	11557
STEDIVOLT SPEED CONTROLLER	39658
QUAD S.S. RELAY	1855167
MOTOR BLOWER	31676 11429
FLUORESCENT BALLAST	34160
FLUORESCENT LAMP	17927
FLUORESCENT SOCKET	34465
UV BALLAST	34160
UL LAMP	18024
UV SOCKETS	20281 20283
STANDARD OUTLET	18231
GFI OUTLET	34921
SELF-RESETTING BREAKER 5A	34331
TRANSFORMER PTC FUSE BUILT IN	34327
MEMBRANE SWITCH CIRCUIT BOARD	40702
MEMBRANE SWITCH	37919
PROXIMITY SWITCH # 1	40671
PROXIMITY SWITCH # 2	40647
DESCRIPTION	BAKER NO.

LEGEND
 BL 54 DENOTES WIRE NO. 54, 22 A.W.G.
 22 ALL WIRES 16 A.W.G. UNLESS OTHERWISE NOTED
 TB-3.4 DENOTES CANOPY TERMINAL BLOCK, TERMINALS 3 OR 4

Caution (Refer to Accompanying documents)

Protective conductor terminal

DRAWN T. Martin DATE 1/10/2005 CHECKED dbessey DATE 1/10/2005	<p align="center">THE BAKER COMPANY</p> <p align="center">161 Galbhouse Rd., Sanford, Maine 04073 USA <i>"Creating Immaculate Atmospheres"</i></p> <p align="center">LADDER SCHEMATIC</p> <p align="center">SterlGARD III SG403A</p> <p>THIS DRAWING AND ITS CONTENTS ARE THE PROPERTY OF THE BAKER COMPANY. THE INFORMATION CONTAINED HEREON MAY NOT BE USED OR COPIED IN ANY MANNER WITHOUT THE WRITTEN PERMISSION OF THE BAKER COMPANY.</p>
DWG NO. 333E522 SHEET B	1 OF 1

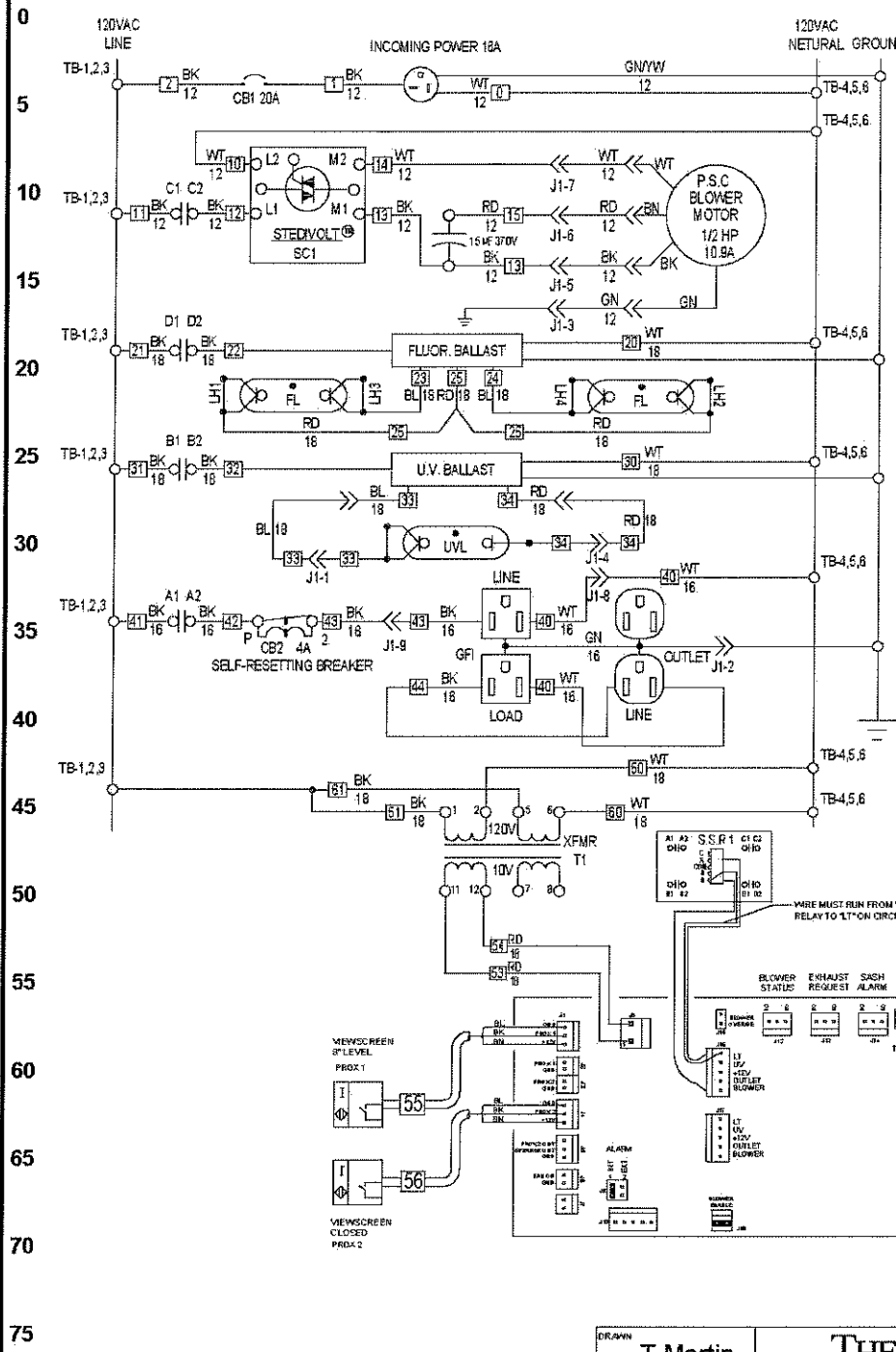

- NEMA 5-20P PLUG
- CIRCUIT BREAKER 40449
- J1, CANOPY LEFT POWER CONNECTOR 37843
- TB, CANOPY TERMINAL BLOCK 40450
- CAPACITOR 40816
- STEDVOLT SPEED CONTROLLER 39658
- QUAD S.S. RELAY 1855167
- MOTOR 40814
- BLOWER 11418
- FLUORESCENT BALLAST 40457
- FLUORESCENT LAMP 17927
- FLUORESCENT SOCKET 34465
- UV BALLAST 34185
- UL LAMP 18025
- UV SOCKETS 20261
- 20263
- STANDARD OUTLET 18231
- GFI OUTLET 34921
- SELF-RESETTING BREAKER 34337
- 4A
- TRANSFORMER 34327
- PTC FUSE BUILT IN
- MEMBRANE SWITCH 40702
- CIRCUIT BOARD
- MEMBRANE SWITCH 37919
- PROXIMITY SWITCH # 1 40371
- PROXIMITY SWITCH # 2 40647

LEGEND

DENOTES WIRE NO. 54, BLUE, 22 A.W.G.

TB-3,4 DENOTES CANOPY TERMINAL BLOCK, TERMINALS 3 OR 4

Caution (Refer to Accompanying documents)

Protective conductor terminal

DRAWN T. Martin	THE BAKER COMPANY 161 Gatehouse Rd., Sanford, Maine 04073 USA <i>"Creating Immaculate Atmospheres"</i>		
DATE 12/22/2004			
CHECKED dbessey	TITLE LADDER SCHEMATIC		
DATE 1/10/2005	FOR SterIGARD III SG603A		
THIS DRAWING AND ITS CONTENTS ARE THE PROPERTY OF THE BAKER COMPANY. THE INFORMATION CONTAINED HERE ON MAY NOT BE USED OR COPIED IN ANY MANNER WITHOUT THE WRITTEN PERMISSION OF THE BAKER COMPANY.		DWG NO. 336E522	A
		SHEET 1 OF 1	

REPLACEMENT PARTS LIST
STERILGARD III ADVANCE , MODEL SG403A & SG603A
VERTICAL LAMINAR FLOW CABINET

	SG403A	SG603A
Part Description	Part #	Part #
Capacitor	11557	11558
Circuit Breaker (Outlets)	34331	34337
Exhaust Hepa Filter	40661	40662
Fluorescent Ballast	34160	40457
Fluorescent Lamp	17927	17927
Front Panel	333X604	336X604
Ground Fault Interrupter Outlet with Indicator Light	34921	34921
Lamp Holder Base	34465	34465
Proximity Switch (Lower)	40647	40647
Proximity Switch (Higher)	40671	40671
Right Angle Micro Cable	40672	40672
Mag Gauge	20773	20773
Membrane Switch Controller	40702	40702
Motor/Blower Speed Controller	39658	39658
Relay, Solid State	1855167	1855167
Terminal Block Asm.	40450	40450
Circuit Breaker (Resetable)	40449	40449
Sash Balance	38014	38172 / 38173
Side Panel, LH (POBM)	333X650	333X650
Side Panel, RH (POBM)	333X651	333X651
Standard Outlet	18231	18231
Supply Blower	11429	11432
Supply Diffuser	333P709	336P709
Supply Hepa Filter	40141	40142
Supply Motor	31676	31679
Switch, Touch Type	37919	37919
Transformer	34327	34327
Ultraviolet Lamp	18024	18025
Ultraviolet Lamp Ballast	34160	34165
Ultraviolet Lamp Socket	20281 / 20283	20281 / 20283
Viewscreen Assembly	333A310	336A310
Viewscreen Frame Assembly	333A311	336A311

Stand Assembly/Leg Extension

The unit is shipped with the legs bolted in the shipping position. The unit has two work-surface height settings per option:

~30 1/8" and 38 5/8" (with the Adjustable Foot Option)

~30" and 36" (with the Caster Option)

- Remove the following parts from the hardware box shipped with the unit. Check the quantities with the list below.

Item No.	Description	Qty.
1	<i>Adjustable Foot or Caster Option</i>	4
2	3/8"-16 x 1" Hex head bolt	8
3	3/8" Lock washer	8
4	3/8" Flat washer	8
5	7/16" Plug button	8

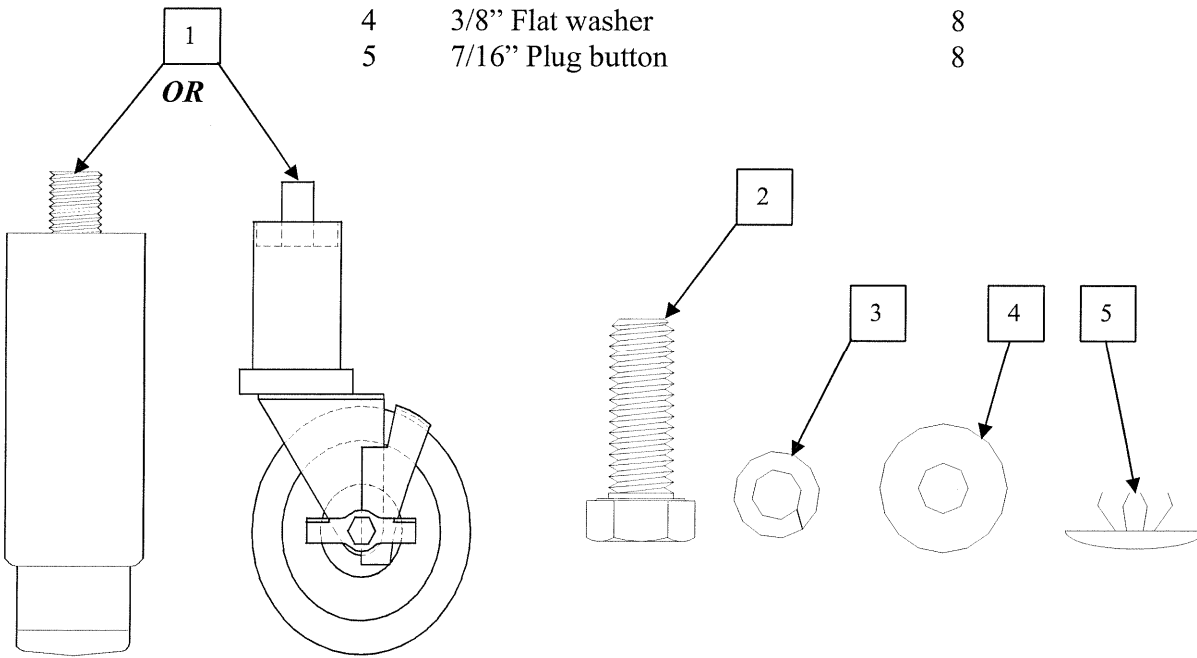

Slide the unit off the Pallet

- To protect the floor finish, use a moving blanket. Carefully slide the unit off the pallet onto the moving blanket.
- Slide the unit into its destination room before going further with the assembly/installation.

Installing the Adjustable Foot or Caster Option

3. Lift one end of the unit/stand assembly up a minimum of 7" and block in position.
See illustration below.
4. Screw in two of the Adjustable Feet or Casters (item # 1). Screw item #1 in by hand as tight as you can and remove the blocks.

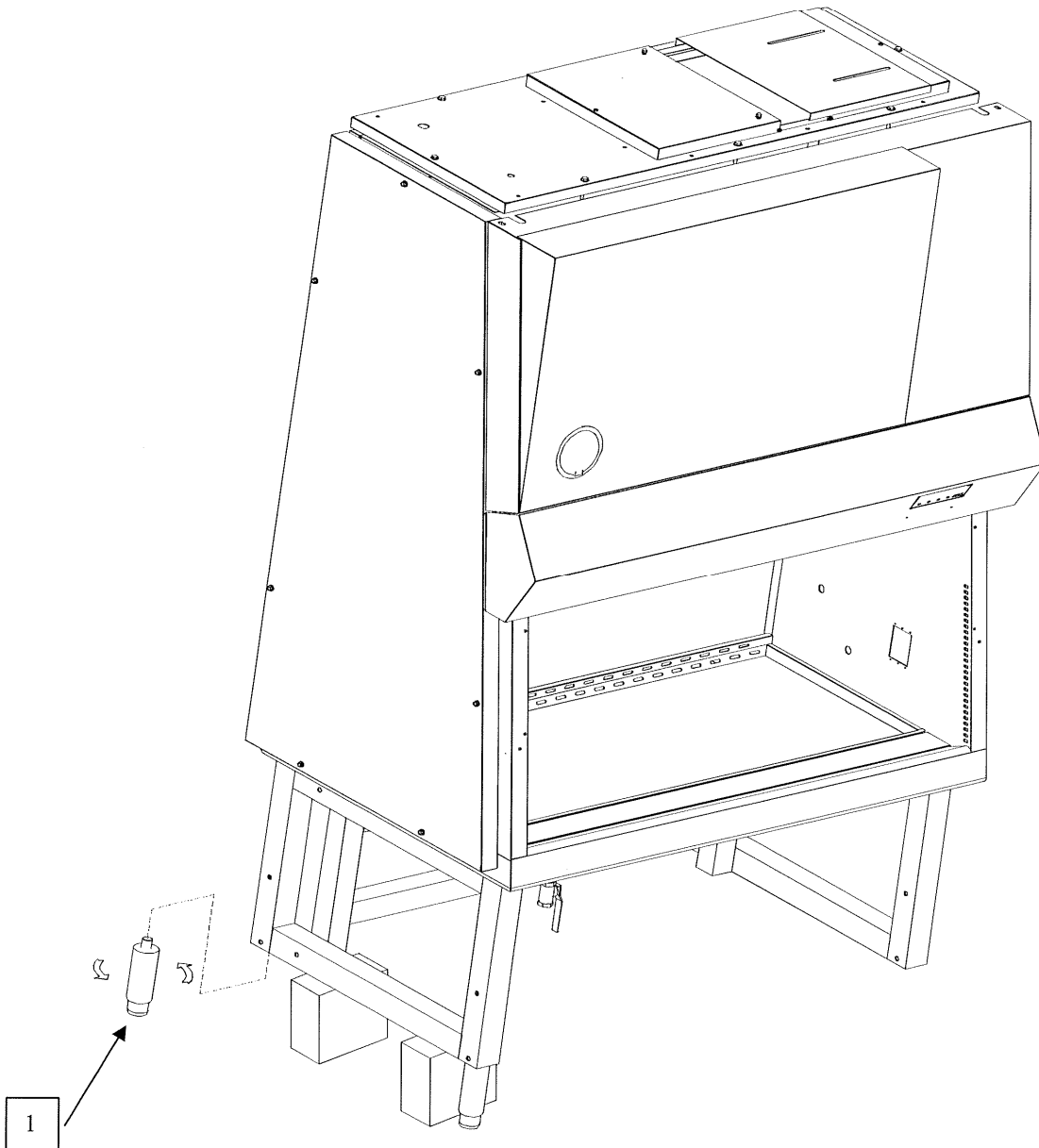

5. If your unit was purchased with the **Caster Option** be sure to **check the previously installed casters** (to avoid cabinet movement) then repeat steps 3 and 4 for the other end of the unit.

6. Only the Adjustable Foot Option is shown above for clarity.

Raise the Unit to 30 1/8" Work-Surface Height (Adjustable Foot Option)
Raise the Unit to 30" Work-Surface Height (Caster Option)

7. Lift one end of the unit up a minimum of 5" and block in position
8. Unscrew the bolts (one per leg) that hold the legs in the shipping position.
9. Slide the leg out of the stand until the holes line up at the next position.

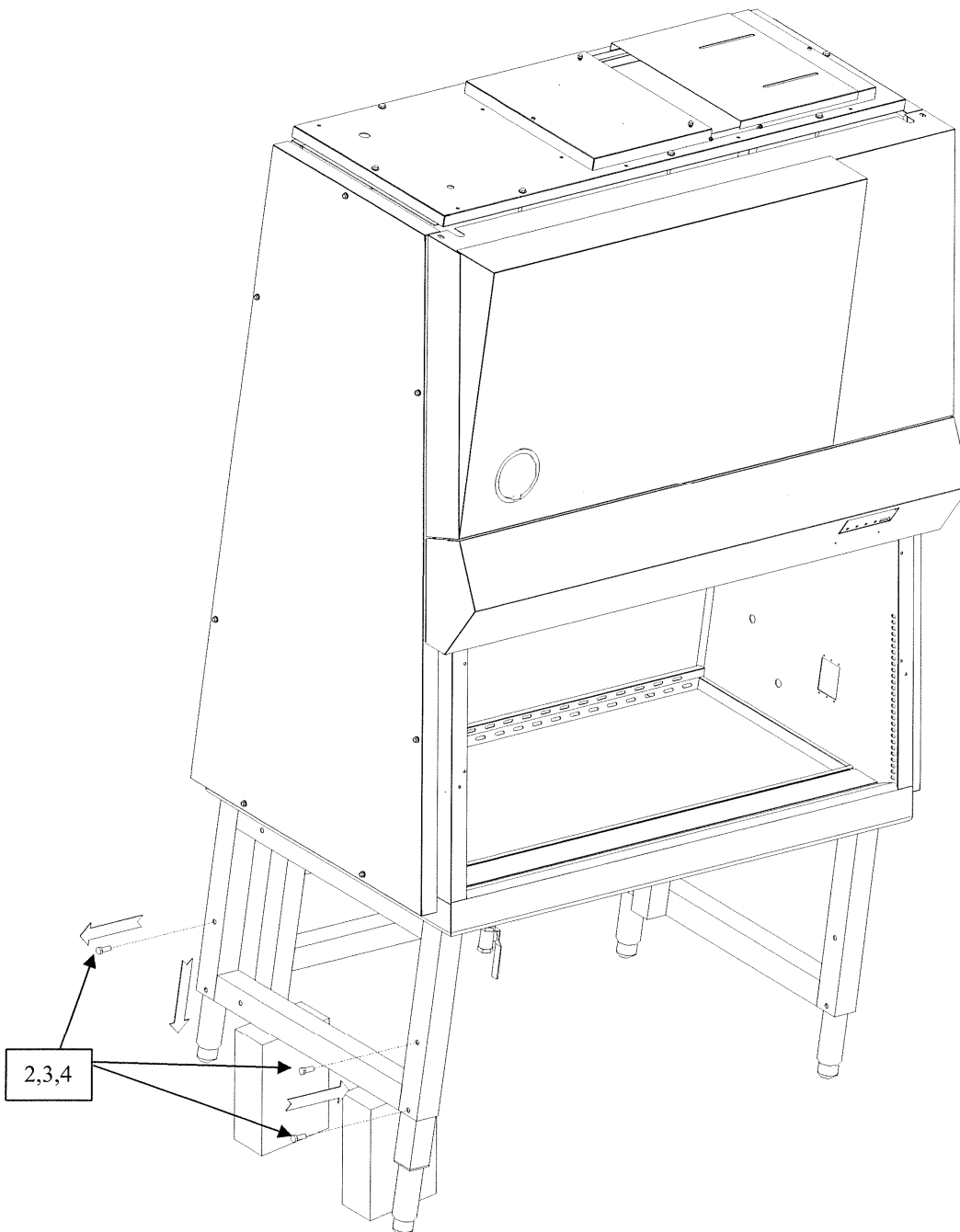

10. Bolt the leg in position with items 2, 3, and 4. (two bolts per leg)
11. Repeat steps 8 and 9 for the other leg and remove blocks.
12. Repeat steps 6 through 10 for the other end of the unit.
13. Plug open holes using item 5. (one per leg)

To raise the Unit to the 38 5/8" Work-Surface Height (Adjustable Foot Option)
To raise the Unit to the 36" Work-Surface Height (Caster Option)

14. Lift one end of the unit up a minimum of 7" and block in position
 15. Unscrew the bolts (two per leg) that hold the legs in the current work-surface-height position.
 16. Slide the leg out of the stand until the holes line up at the next position.
 17. Bolt the leg in position with items 2, 3, and 4. (two bolts per leg)
 18. Repeat steps 15 and 16 for the other leg and remove blocks.
 19. Repeat steps 13 through 17 for the other end of the unit.
 20. Plug open holes using item 5. (Two per leg *Adjustable Foot Option*)
 (One per leg *Caster Option*)
-

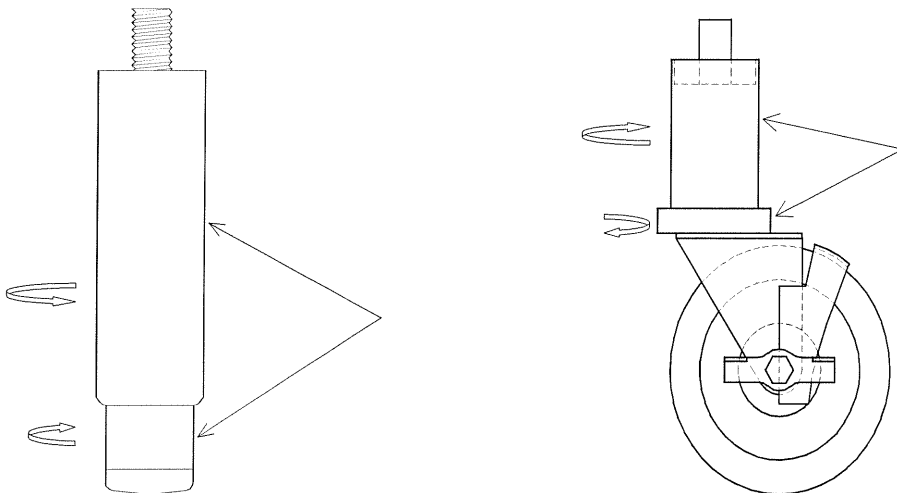

Turn in opposing directions for fine adjustment to aid in leveling of cabinet.
 SEE ILLUSTRATIONS ABOVE

THE PROPER WAY TO INSTALL OR REMOVE CHANNEL STANDS

To install a stand please follow steps (1-7). To remove a stand, please reverse steps (1-7).

STEP 1 : First gather all stand components and attaching hardware. The stand parts consist of two sides and one back support. Hardware consist of (4) 1/4"x 1-1/4" bolts w/ 1/4" flat/lock washers and 1/4" hex nuts (4) 3/8" x 1 bolts w/ 3/8" flat/lock washers (8)chrome dots (4) Adjustable leg levelers. Tools required are a 7/16" wrench or deep socket, 9/16" wrench or socket.

STEP 2 : Place stand sides on the floor so that the stainless steel legs are setting on the floor. Next place the stand back support between the sides so that the open part of the channel is towards the floor. This can also be done by rotating the stand parts (360 degrees), to make attaching the hardware easier.

STEP 3 : Using the 3/8 hardware, attach the sides and back support by inserting the bolts thru the (4) holes located in the support into the already installed rivnuts in the two sides. (2) bolts each side. Do not tighten any of these bolts until you have all (4) of them threaded in slightly. Tighten bolts after this is done.

STEP 4 : With stand assembly complete, rotate stand so that the back of the sides are setting flat on the floor. Attach leg leveler legs by screwing them into the bottom of the stainless steel legs in the sides of stand assembly. Position the stand assembly in the upright position so that the leg levelers are now resting on the floor. The stainless steel legs can be adjusted to your desired height requirement. This is done by removing and replacing the (2) 3/8"bolts in each leg. Unused rivnuts in the legs will be plugged with the (8) chrome dots. If the cabinet is not in it's permanent location you may want to perform the leg adjustment after step. 7:

STEP 5 : Cabinet must now be lifted high enough to allow clearance for stand assembly to be positioned under it. This is typically done from the front of the cabinet. Stand assembly is slid in from the back of the cabinet. If space constraints are an issue, the stand may have to be assembled under the cabinet after it has been lifted.

STEP 6 : Once the stand is positioned under the cabinet you must then install (4) 1/4"x 1-1/4" bolts into the key way slots located under the cabinet in each of the (4) corners. Cabinet is now ready to be lowered onto the stand assembly. There are

(4) holes on the top of the stand which the 1/4"x1-1/4" bolts must be guided thru. Be careful not to let the bolts drag thru the holes while lowering as burrs may occur and cause cross threading. With the cabinet resting on top of the stand assembly, place (1) 1/4" flat / lock washer / hex nut/ onto each of the 1/4x1-1/4" bolts. Tighten after all (4) are threaded on.

STEP 7 : Lift device should be removed if not being used to move cabinet into position. If lift device is mobile it may be used to maneuver cabinet into desired location. A blanket could also be placed under leg levelers to slide unit as to not scuff flooring.

CONGRATULATIONS YOU HAVE SUCCESSFULLY ASSEMBLED AND INSTALLED A CHANNEL STAND.

In-field Fluorescent and Ultraviolet Lamp Replacement Instructions

SG403A & SG603A

Fluorescent Lamp Replacement

1. Turn the fluorescent lamps off by depressing the light on/off switch locating on the right side of the light canopy.
2. Next, pull the vertical panel **out** enough at the bottom so that the thumbscrews can be accessed. (Fig.1). While loosening the thumbscrews, support the light canopy with the other hand and lower until restraint cables hold canopy in place. **CAUTION: Use care when pulling vertical cover out at the bottom to access thumbscrews. DO NOT LIFT UP , unless removal of panel is necessary.**

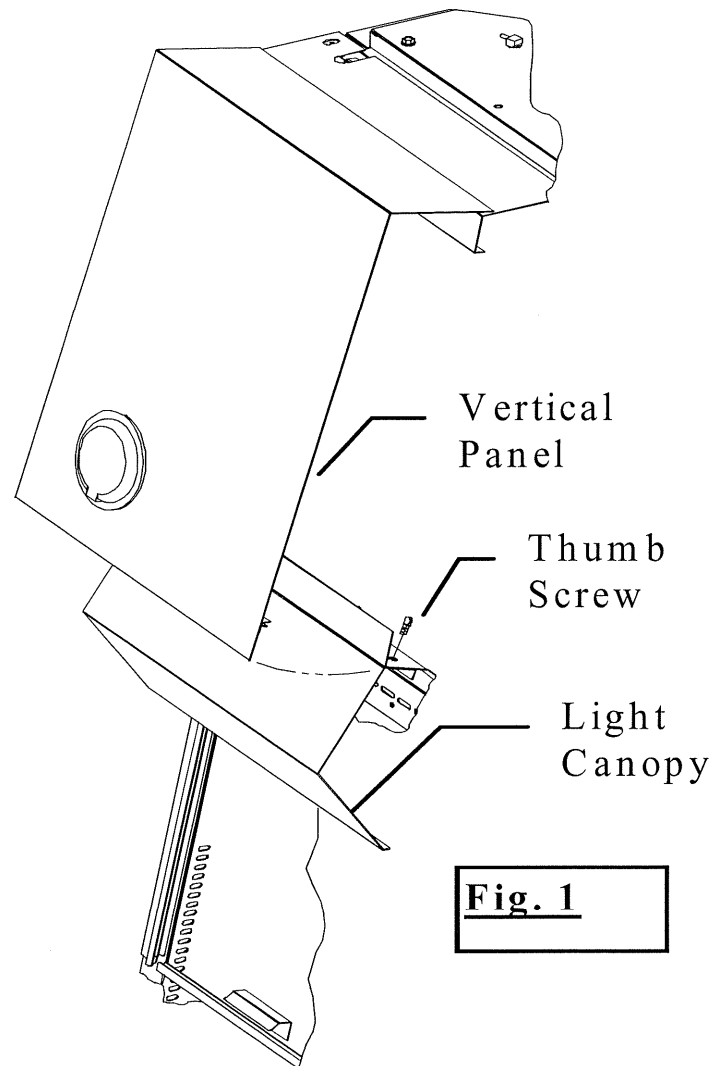

3. Disconnect the restraint cables from the face of the unit at both ends of the light canopy (Fig. 2) and gently hinge canopy down until it rests on the front of the unit.

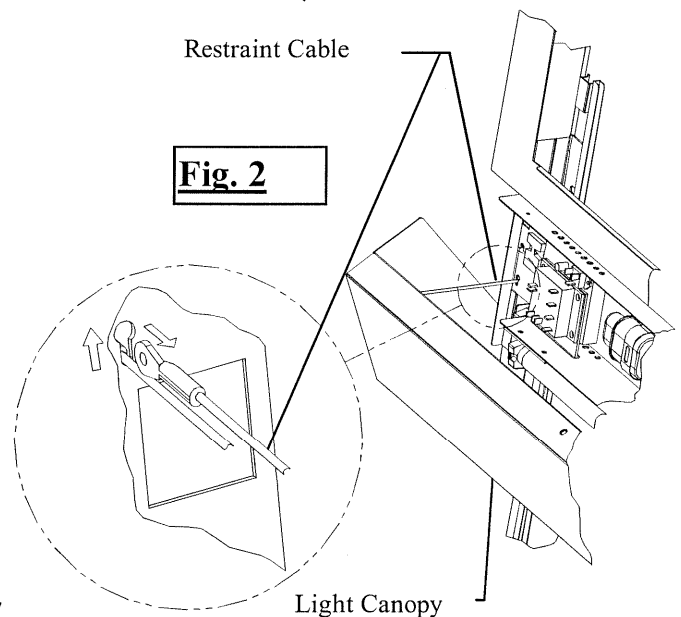

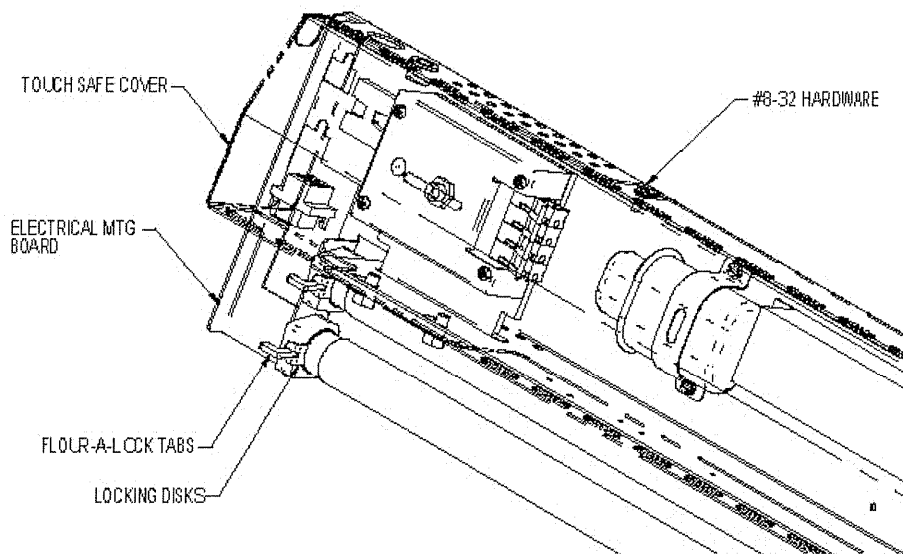

Figure 3

4. Next remove locking tabs (2) from the lamp holders located on the left side of the fluorescent lamps. (See Figure 3) Next using both hands, grasp the lamp carefully near each end and rotate it away from the cabinet approx $\frac{1}{4}$ turn until the lamp is no longer seated in the holders. Remove the second lamp as instructed and dispose of them properly.
5. Install new lamps using the reverse directions listed, making sure that the locking disks are installed on one end of the lamp and that the *FLUOR-A-LOCK* tabs are inserted properly. (See Figure 3.)
6. Hinge light canopy temporarily and press the light on/off switch and verify that both lamps are working.
7. Lower canopy halfway and re-insert restraint cables on either end of electrical mounting board, close canopy, install thumbscrews and tighten. Finally, lower the vertical panel slowly.
8. The fluorescent lamp replacement is now complete.

Ultraviolet Lamp Replacement

1. As reported in other sections of this manual, UV germicidal lamps lose their effectiveness over time and should be replaced when the intensity at the work surface

drops below 40 microwatts per square centimeter at a wavelength of 253.5×10^{-9} meters.

2. **Caution:** Before replacing a UV germicidal lamp it might be necessary to check with an industrial hygienist, safety officer or other qualified person in the lab to make sure that there is nothing stored in the cabinet that could potentially be a hazard to you or could be contaminated by room air.
3. First, raise the viewscreen to its maximum position. The audible alarm should activate and the indicator on the light canopy will flash. To mute this audible alarm while the UV lamp is being replaced, press the alarm reset button located on the light canopy. After five minutes the alarm will sound again and you may press the reset button if more time is needed for lamp replacement.
4. Next using both hands, grasp the UV lamp carefully near each end and move it $\frac{1}{2}$ " to the right side of the cabinet until the UV lamp is released from the lamp holder on the left side. Carefully remove lamp from cabinet and dispose of them properly.
5. Install new lamp using the previous instructions in reverse, making sure that the lamp is held securely in place.
6. Finally, lower the viewscreen to the proper sash opening height in order to cancel the audible alarm and flashing indicator light.
7. The replacement is now complete.

SG 403A / 603A ADVANCED °
EXHAUST TRANSITION SYSTEM
FIELD INSTALLATION INSTRUCTIONS
(For model HEC 403A, HEC 603A, CEC 403A & CEC 603A)

Tools required:

- 5/16 - Hex wrench and nut driver
- 11/32 - Hex wrench and nut driver**
- 3/8 - Hex wrench and nut driver
- 7/16 - Hex wrench and nut driver
- 11/32 - Combination wrench

CAUTION: If your cabinet has been in service, make sure you decon it before installing the HEC (Hard Exhaust Connection) or CEC (Canopy Exhaust Connection).

UNPACKING:

1. Remove contents from their shipping package and examine for damage. *(Be careful not to damage the gasket on the bottom flange of the exhaust transition)*
2. Check the quantity of the components to the following packing lists and illustrations:
 - Figure 1:** Type A cabinet – Exhausting to room
 - Figure 2:** Hard Exhaust Connection (HEC)
 - Figure 3:** Canopy Exhaust Connection (CEC)

Packing List for HEC

Item	Description	Qty SG403A	Qty SG 603A
1	Exhaust transition	1	1
2	Exhaust filter access cover (closed face)	1	1
3	¼”-20 x ¾” Washer head bolt	4	6
4	¼” Seal washer	6	8
5	¼”-20 x 1” Hex head bolt	4	4
6	¼” Flat washer	6	6
7	¼” Lock washer	6	6
8	¼”-20 Double ended transition mounting bolt	2	2
9	¼”- 20 Hex nut	2	2
10	Exhaust transition mounting clip	2	2
11	Air tight damper assembly (ATD)	1	1
12	Short exhaust collar (Optional)	1	1
13	#8-32 Cap nut	8	8
14	#8 Flat washer	8	8
15	#8 Lock washer	8	8
16	Exhaust transition gasket, ¼” x ½”	8.3 ft	10.3 ft
17	Access cover gasket, ¼” x ½”	6.2 ft	8.2 ft
18	Exhaust collar gasket, 1/8”	1	1

*Items shipped loose in the packaging.

Packing List for CEC

<i>Item</i>	Description	Qty SG403A	Qty SG 603A
1	Exhaust transition	1	1
2	Exhaust filter access cover (open face)	1	1
3	¼"-20 x ¾" Washer head bolt	4	6
4	¼" Seal washer	6	8
5*	¼"-20 x 1" Hex head bolt	4	4
6*	¼" Flat washer	6	6
7*	¼" Lock washer	6	6
8*	¼" 20 Double ended transition mounting bolt	2	2
9*	¼"-20 Hex nut	2	2
10*	Exhaust transition mounting clip	2	2
11*	Air tight damper assembly (ATD)	1	1
12*	Short exhaust collar (Optional)	1	1
13*	#8-32 Hex nut	4	4
14*	#8 Flat washer	4	4
15*	#8 Lock washer	4	4
16	Exhaust transition gasket, ¼" x ½"	8.3 ft	10.3 ft
17	Access cover gasket, ¼" x ½"	6.2 ft	8.3 ft
18	Decon Seal Box Assembly (Optional)	1	1
19	#8-32 Hex Head Screw	8	8
20			

*Items shipped loose in the packaging.

EXHAUSTING REQUIREMENTS:

All Exhaust Flow Rates listed below for HEC (Hard Exhaust Connection) are based on a nominal 105 FPM intake velocity.

HEC EXHAUSTING REQUIREMENTS:

HEC

Cabinet Model	Transition Model	Sash Height (Inchs)	Exhaust Flow Rate (cfm)	Pressure Loss (" w.c.)	Added Height to Type A Cabinet with ET. ATD / SHORT COLLAR (Inchs)	Exhaust Duct Diameter (Inchs)
SG403A	HEC403A	8	269	0.06	11-1/2 / 5-5/16	10
SG403A	HEC403A	10	335	0.08	11-1/2 / 5-5/16	10
SG603A	HEC603A	8	408	0.10	11-1/2 / 5-5/16	10
SG603A	HEC603A	10	510	0.15	11-1/2 / 5-5/16	10

INSTALLATION INSTRUCTIONS FOR HEC:

(Reference Figures 1 & 2)

NOTE: Cabinets shipped with exhaust transition assemblies already installed, proceed to step 7 to complete the installation.

1. Remove the exhaust filter protector assembly located over the exhaust filter opening by removing two (2) #8-32 locking nuts and washers. This assembly will no longer be required.
2. **Remove the exhaust filter access panel [Item 2] from the front of the transition by removing four (4) bolts with seal washers [Items 3 & 4 (Detail A)].**
3. Remove two (2) top panel-mounting bolts located in front of the exhaust filter opening. Install two (2) ¼" double ended transition mounting bolts with seal washers [Items 4 & 8] The longer end threads into the cabinet.
4. Place the exhaust transition over the exhaust filter opening. Align the two holes at each end of the transition with the ¼" female fasteners that are located at each side of the exhaust filter opening.
5. Install the transition mounting hardware [Items 5, 6&7 (Detail C)] along with transition mounting clip and hardware on the double ended mounting bolt [Items 6, 7, 9 & 10 (Detail D)]. Tighten all hardware until the transition gasket is compressed between 25 to 50 percent.
6. Reinstall the exhaust filter access cover. [Item 2 (Detail A)].
7. Attach the airtight damper assembly (ATD) [Item 11] or optional short collar [Item 12] along with gasket to the eight (8) studs located at the top of the transition using #8 hardware [Items 13, 14 & 15 (Detail B)].

With the HEC installed and connected to the building exhaust system the cabinet should be certified by a qualified technician to assure proper cabinet performance.

All Exhaust Flow Rates listed below for CEC (Canopy Exhaust Connection) are based on a nominal 105 FPM intake velocity.

If the cabinet intake varies from the nominal 105 FPM, adjust the exhaust flow rate to a minimum of 20% over the intake airflow.

CEC EXHAUSTING REQUIRMENTS: (Continued)

CEC

Cabinet Model	Transition Model	Sash Height (Inchs)	Exhaust Flow Rate Min/Max (cfm)	Pressure Loss Min/Max (" w.c.)	Pressure Loss with BSC Sealed for Decon. (" w.c.)	*Intake Velocity (fpm)	Additional Heights (Inchs)	Exhaust Duct Dia. (Inchs)
SG403A	CEC403A	8	322 520	0.05 0.25	0.20	89	ET 3.80" Decon Box 3.0" Short Collar 1.50" ATD 7.75"	10
SG403A	CEC403A	10	401 585	0.08 0.30	0.30	82	SAME AS ABOVE	10
SG603A	CEC603A	8	490 754	0.15 0.40	0.34	85	SAME AS ABOVE	10
SG603A	CEC603A	10	613 914	0.20 0.50	0.60	84	SAME AS ABOVE	10

* = With exhaust sealed off

INSTALLATION INSTRUCTIONS FOR CEC:

(Reference Figures 1 and 3)

NOTE: Cabinets shipped with exhaust transition assemblies already installed, proceed to step 7 to complete the installation.

1. Remove the exhaust filter protector assembly located over the exhaust filter opening by removing two (2) #8-32 locking nuts and washers. This assembly will no longer be required.
2. Remove the exhaust filter access panel [Item 2] from the front of the transition by removing four (4) bolts with seal washers [Items 3 & 4 (Detail A)].
3. Remove the two (2) top panel-mounting bolts located in front of the exhaust filter opening. Install two (2) ¼" double ended transition mounting bolts with seal washers [Items 4 & 8]. The longer end threads into the cabinet.
4. Place the exhaust transition over the exhaust filter opening. Align the two holes at each end of the transition with the ¼" female fasteners that are located at each side of the exhaust filter opening.
5. Install the transition mounting hardware [Items 5, 6&7 (Detail B)] along with transition mounting clip and hardware on the double ended mounting bolt [Items 6, 7, 9 & 10 (Detail C)]. Tighten all hardware until the transition gasket is compressed 25 to 50 percent.
6. Reinstall the exhaust filter access cover [Item 2 (Detail A)].
7. If the Decon Seal Box (optional) was ordered for your cabinet, first remove the side panels by loosening the (4) hex head screws as shown in figure 3. Place the decon seal box on top of the exhaust transition so that all four weld studs are located properly. Install (1) one flat washer, (1) one lock washer, and (1) one #8-32 nut provided, onto each weld stud and tighten accordingly. Re-install side covers onto seal box and tighten. Mount optional short collar [Item 12] and gasket to the eight (8) studs located at the top of the transition using #8 hardware [Items 13, 14 & 15 (Detail B)].

With the CEC installed and connected to the building exhaust system the cabinet should be certified by a qualified technician to assure proper cabinet performance.

Figure 1: Type A2 cabinet – Exhausting to room

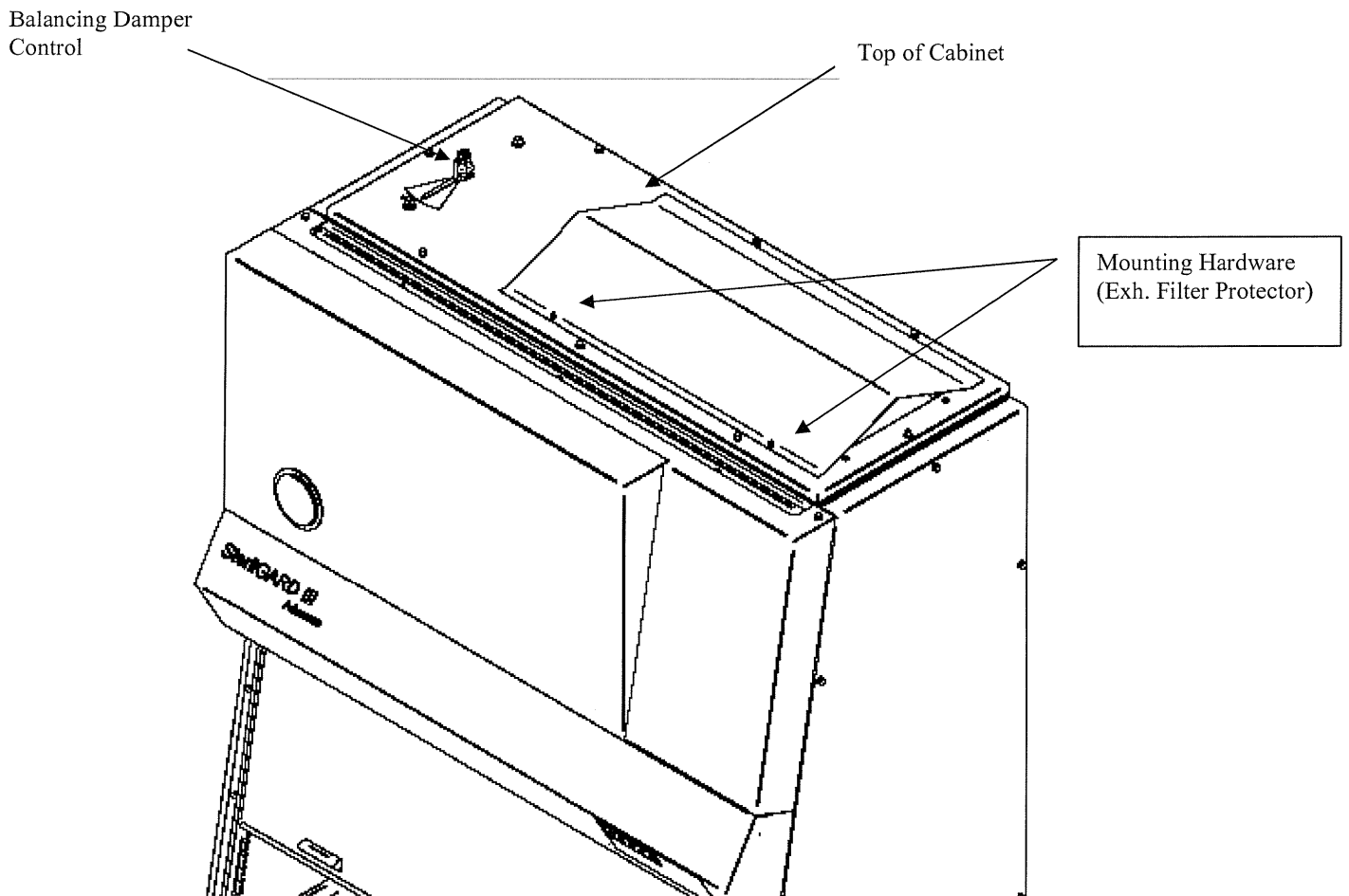

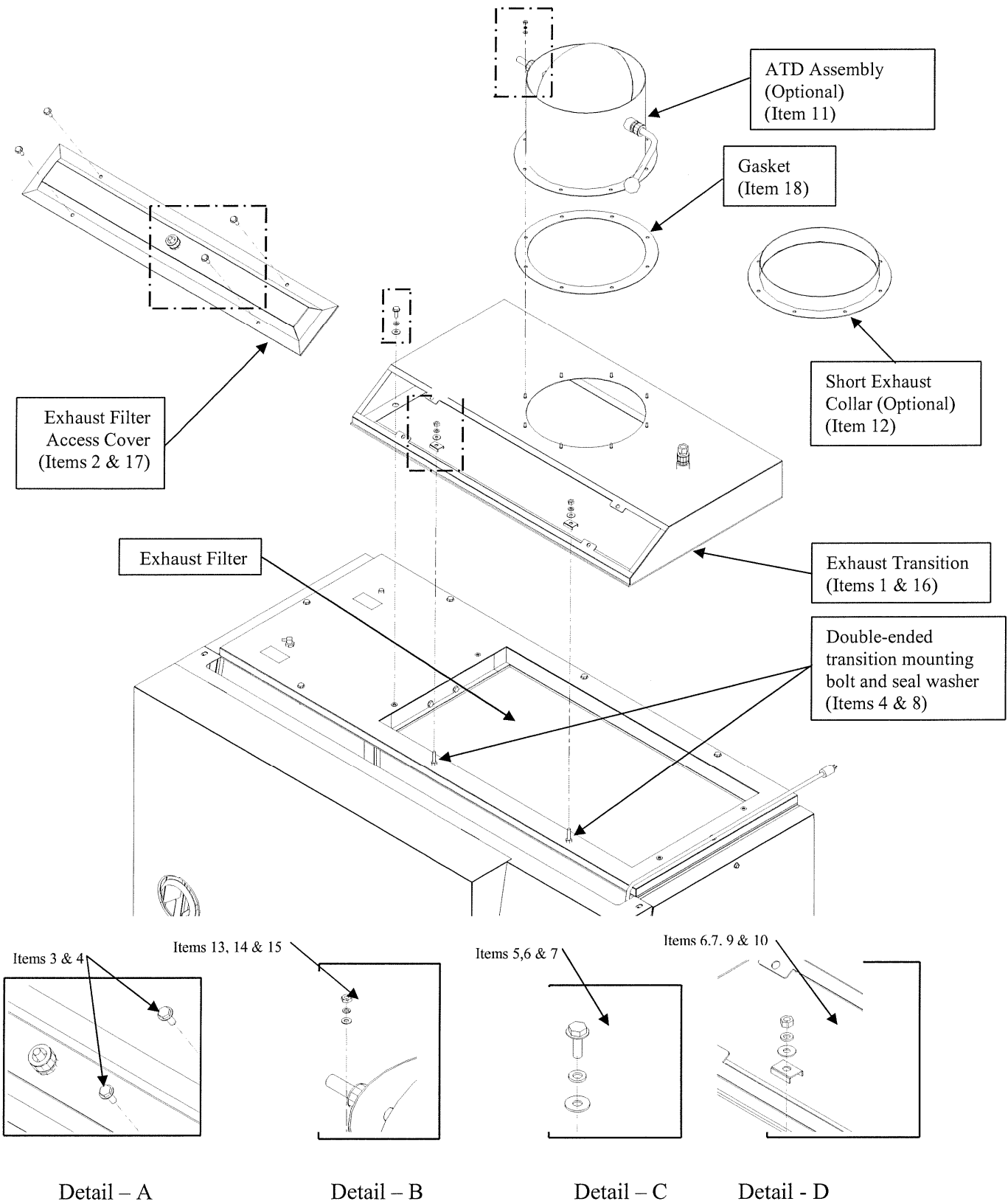

Figure 2: Hard Exhaust Connection (HEC)

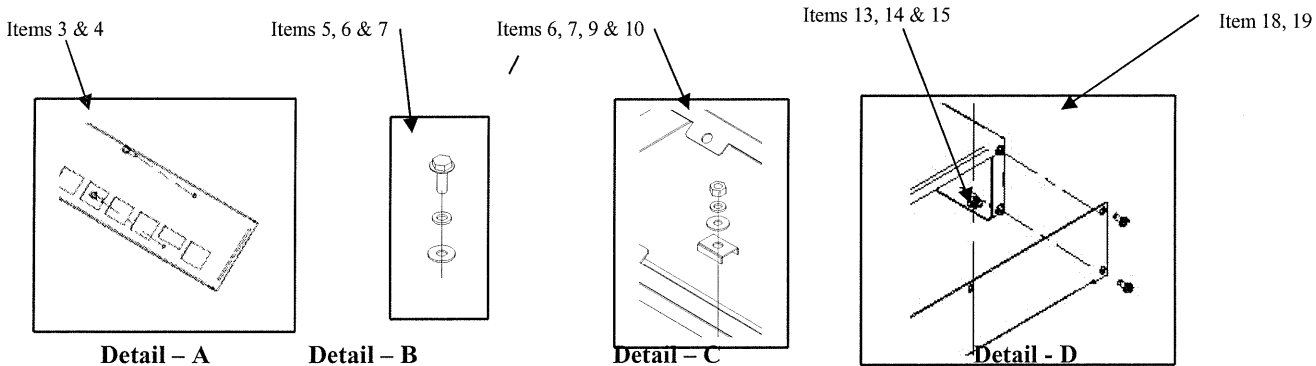
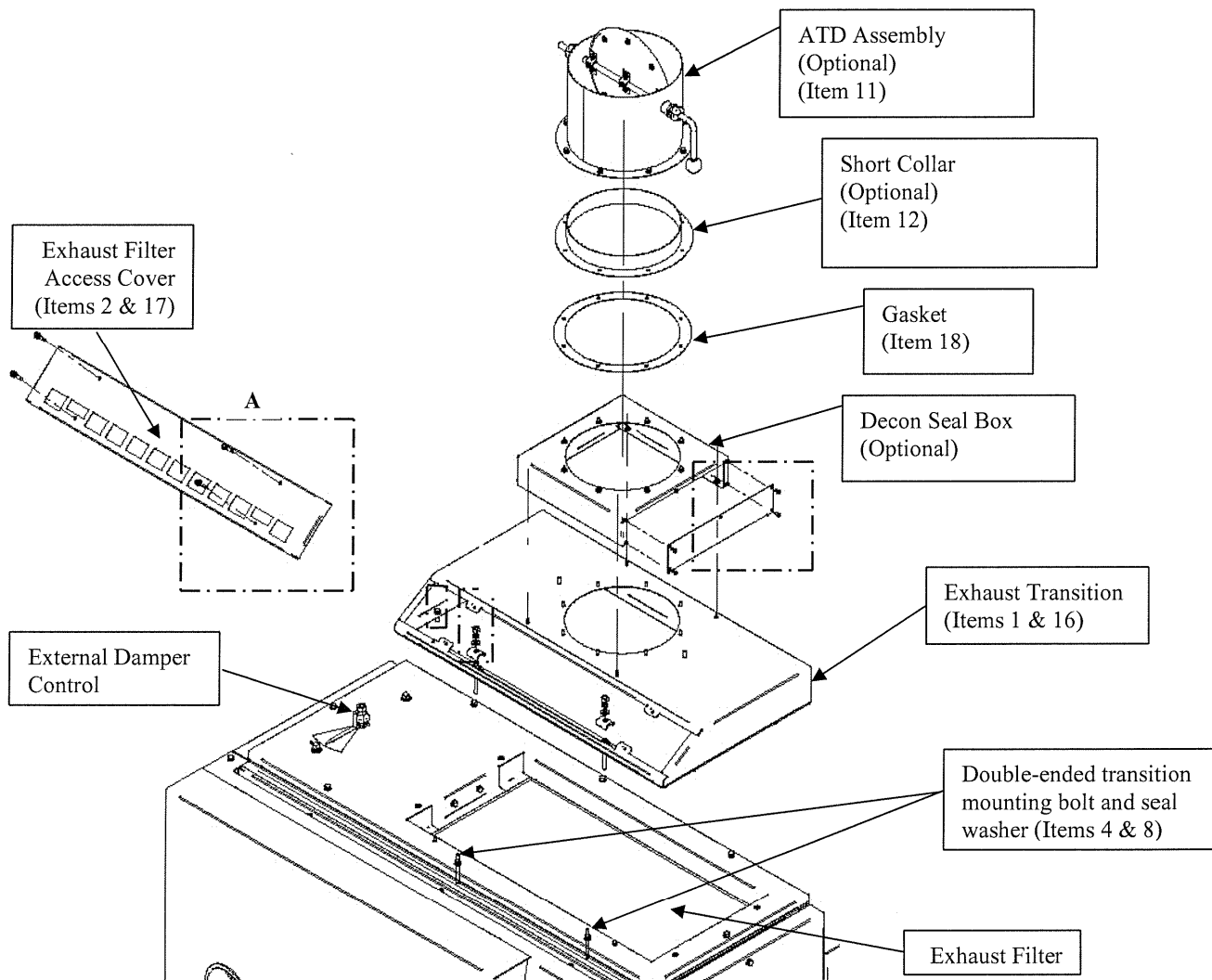
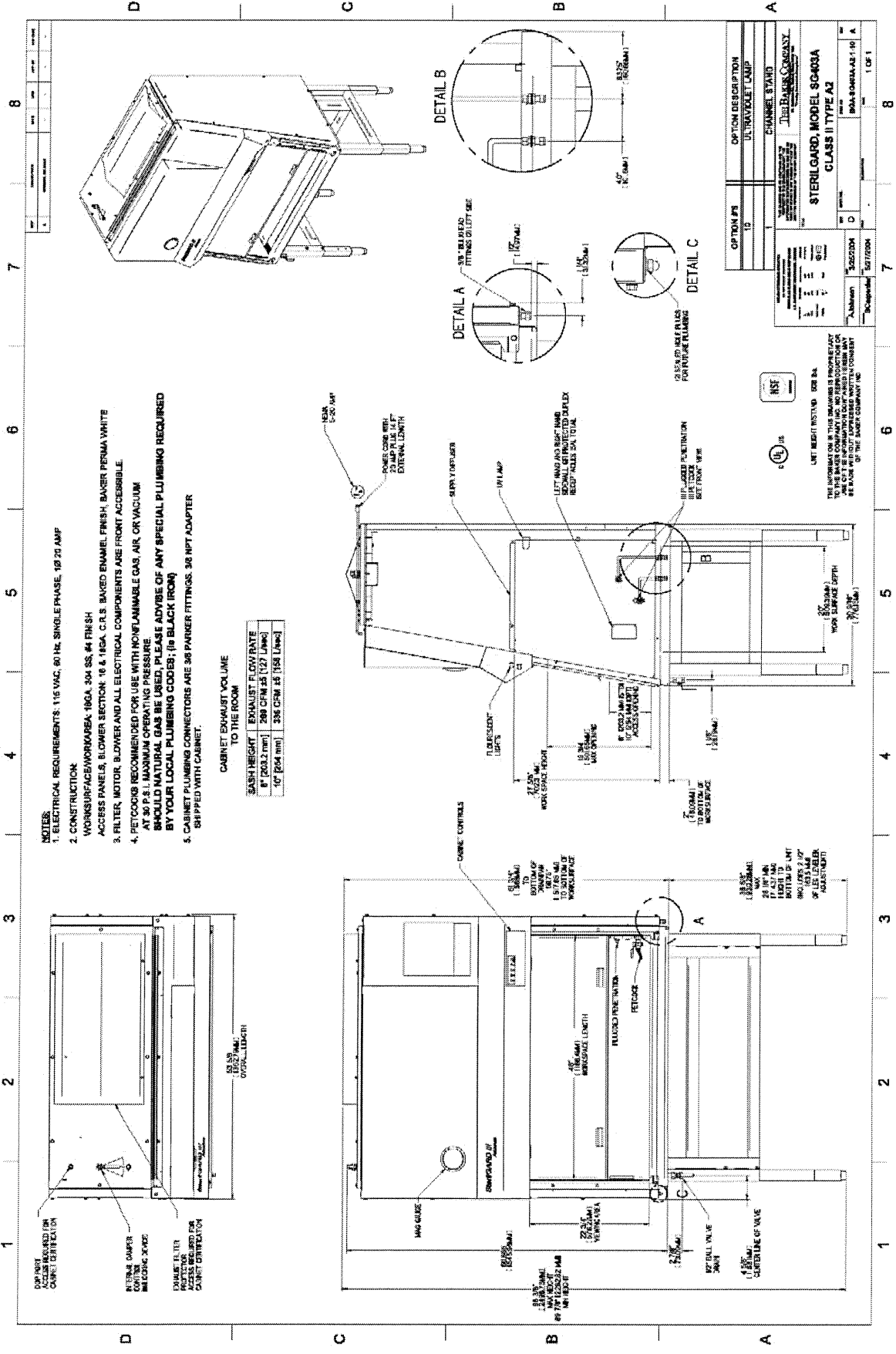

Figure 3: Canopy Exhaust Connection (CEC)



- NOTES:**
1. ELECTRICAL REQUIREMENTS: 115 VAC, 60 Hz, SINGLE PHASE, 19.75 AMP
 2. CONSTRUCTION
WORKSURFACE/WORKAREA: 18GA. 304 SS, 44 FINISH
ACCESS PANELS, BLOWER SECTION: 16 G. 18GA. C.R.S. BAKED ENAMEL FINISH, BAKER PERSMA WHITE
 3. FILTER, MOTOR, BLOWER AND ALL ELECTRICAL COMPONENTS ARE FRONT ACCESSIBLE.
 4. FITTINGS RECOMMENDED FOR USE WITH NONFLAMMABLE GAS, AIR, OR VACUUM AT 30 P.S.I. MAXIMUM OPERATING PRESSURE.
SHOULD NATURAL GAS BE USED, PLEASE ADVISE OF ANY SPECIAL PLUMBING REQUIRED BY YOUR LOCAL PLUMBING CODES; (IS BLACK IRON)
 5. CABINET PLUMBING CONNECTORS ARE 3/8 PARRER FITTINGS, 3/8 NPT ADAPTER SHIPPED WITH CABINET.

CABINET EXHAUST VOLUME TO THE ROOM

SASH HEIGHT	EXHAUST FLOW RATE
6" (152.4 mm)	288 CFM ±5 (127 L/min)
10" (254 mm)	336 CFM ±5 (154 L/min)

OPTION #1	OPTION DESCRIPTION
12	ULTRAVIOLET LAMP
CHANNEL STAND	
STERILGARD, MODEL 90403A CLASS II TYPE A2	
BIO-SAFE COMPANY	
1000 W. 10TH AVENUE, SUITE 100, DENVER, CO 80202	
TEL: (303) 733-1100 FAX: (303) 733-1101	
WWW.BIO-SAFE.COM	
Model	90403A
Revision	1.0
Author	BAK/SAR/AS-10
Checker	BAK/SAR/AS-10
Approver	BAK/SAR/AS-10
Date	10/1/01

NSF
cUL 25
LIST WEIGHT LISTED SEE BA

THE INFORMATION IN THIS DRAWING IS PROPRIETARY TO THE BIO-SAFE COMPANY, INC. NO REPRODUCTION OR USE IN ANY MANNER WITHOUT THE WRITTEN PERMISSION OF THE BIO-SAFE COMPANY, INC.

A	ORIGINAL RELEASE	DATE	DRN	APP-SY	APP-DATE
B	DEL 38026, UPDATE WIRING PER ECR00417	9/28/04	TFM	APP-SY	APP-DATE

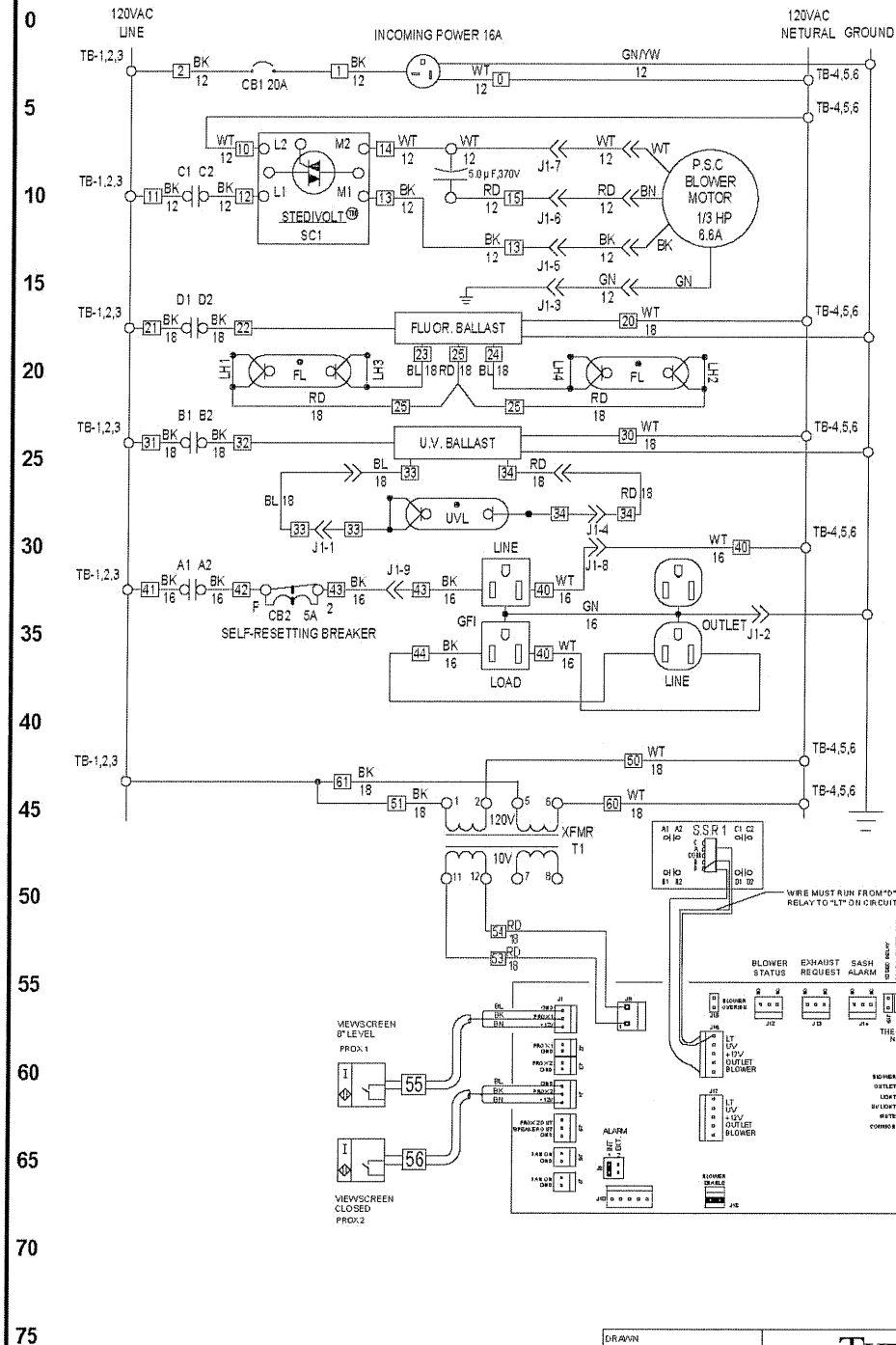

NEMA 5-20P PLUG	32897
CIRCUIT BREAKER	40449
J1, CANOPY LEFT POWER CONNECTOR	37843
TB, CANOPY TERMINAL BLOCK	40450
CAPACITOR	11557
STEDIVOLT SPEED CONTROLLER	39658
QUAD S.S. RELAY	1855167
MOTOR BLOWER	31676 11429
FLUORESCENT BALLAST	34160
FLUORESCENT LAMP	17927
FLUORESCENT SOCKET	34465
UV BALLAST	34160
UL LAMP	18024
UL SOCKETS	20281 20283
STANDARD OUTLET	18231
GFI OUTLET	34921
SELF-RESETTING BREAKER 5A	34331
TRANSFORMER PTC FUSE BUILT IN	34327
MEMBRANE SWITCH CIRCUIT BOARD	40702
MEMBRANE SWITCH	37919
PROXIMITY SWITCH # 1	40671
PROXIMITY SWITCH # 2	40647
DESCRIPTION	BAKER NO.

LEGEND
 54-22 DENOTES WIRE NO. 54, 22 A.W.G.
 ALL WIRES 16 A.W.G. UNLESS OTHERWISE NOTED
 TB-3.4 DENOTES CANOPY TERMINAL BLOCK, TERMINALS 3 OR 4

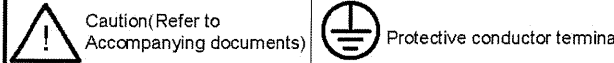

DRAWN T.Martin DATE 1/10/2005 CHECKED dbessey DATE 1/10/2005	<div style="text-align: center;"> THE BAKER COMPANY 161 Gatehouse Rd., Sanford, Maine 04073 USA <i>"Creating Immaculate Atmospheres"</i> </div> TITLE LADDER SCHEMATIC FCR SterIGARD III SG403A	DWG NO. 333E522 SHEET 1 OF 1
THIS DRAWING AND ITS CONTENTS ARE THE PROPERTY OF THE BAKER COMPANY. THE INFORMATION CONTAINED HEREON MAY NOT BE USED OR COPIED IN ANY MANNER WITHOUT THE WRITTEN PERMISSION OF THE BAKER COMPANY.		B

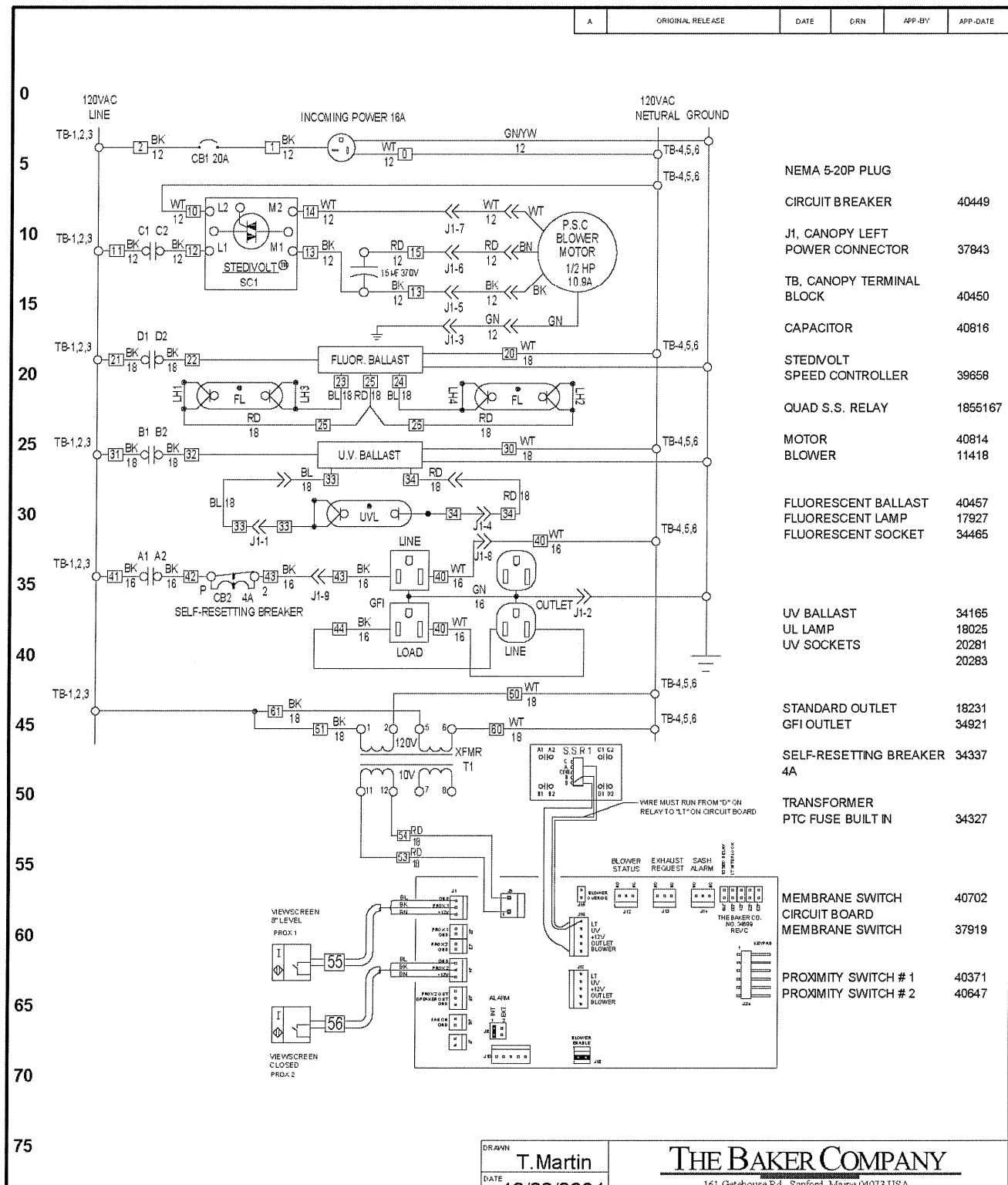

A	ORIGINAL RELEASE	DATE	DRN	APP-BY	APP-DATE
---	------------------	------	-----	--------	----------

LEGEND

DENOTES WIRE NO. 54, BLUE, 22 A.W.G.

DENOTES CANOPY TERMINAL BLOCK, TERMINALS 3 OR 4

Caution (Refer to Accompanying documents)

Protective conductor terminal

DRAWN	T.Martin	THE BAKER COMPANY 161 Gathouse Rd., Sanford, Maine 04073 USA <i>"Creating Immaculate Atmospheres"</i>			
DATE	12/22/2004				
CHEKED	dbessey	TITLE	LADDER SCHEMATIC		
DATE	1/10/2005	FCR	SteriGARD III SG603A		
		THIS DRAWING AND ITS CONTENTS ARE THE PROPERTY OF THE BAKER COMPANY. THE INFORMATION CONTAINED HERE ON MAY NOT BE USED OR COPIED IN ANY MANNER WITHOUT THE WRITTEN PERMISSION OF THE BAKER COMPANY		DWG NO.	336E522
				SHEET	A
				1 OF 1	

The Baker Company
Airflow Monitor (AFM) Installation Instructions
(For SG403A / 603A Exhaust To Room, HEC or CEC)

Exhaust To Room Installation Instructions:

1. Remove all items from shipping container and identify the following: Contents should include 1) Airgate with 1" probe installed, 2) AFM (Airflow Monitor) and Velcro Strip (if AFM was not factory installed).
2. Insert the 1" long AFM probe into the shaft collar located on top of the airgate if not already complete. The probe has a long scratch mark on its side. Rotate the probe so the mark is positioned to the left side of the shaft collar as shown in *Detail A*. This will orientate the thermistors (glass beads) on the probe tip in a horizontal plane so it can properly sense the airflow. Fully insert the probe so the tip passes through the hole in the airgate approximately 3/32" of an inch. Tighten the retaining collar set screw carefully. Do not over tighten. (*Make sure not to rotate the probe while tightening*).
3. Remove the #8-32 hardware already fastened to the two weldstuds on top of the cabinet.
4. Next grasp the Airgate and carefully lower it onto the top seal panel locating the keyhole contour onto the far left weld stud as shown in *figure 1*. Once in place slide the Airgate to the far left until it stops. Route probe wiring behind front access panel and plug into AFM. Be sure to tie up extra probe cord length in order to prevent interference with viewscreen.
5. Next place the Exhaust Filter Protector on top of the unit locating the holes onto the two front weldstuds and replace #8-32 hardware and tighten.

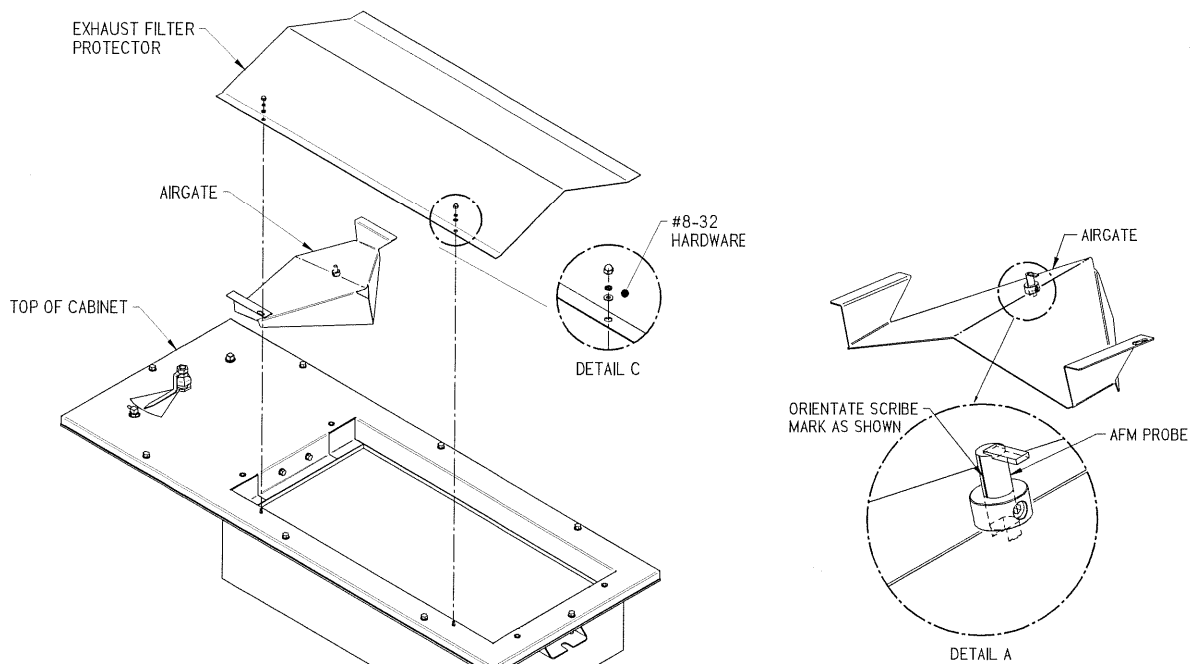

FIGURE 1

HEC or CEC Installation Steps:

1. Remove all items from shipping container and identify the following: Contents should include 1) Airgate, 2) AFM (Airflow Monitor) with 1” probe, 3) #8-32 locknut, 4) Cardboard protector sheet, 5) Velcro Strip. (See Figure 2)
2. Insert the 1” long AFM probe into the shaft collar located on top of the airgate. The probe has a long scratch mark on its side. Rotate the probe so the mark is positioned to the left side of the shaft collar as shown in *Detail A*. This will orientate the thermisters (glass beads) on the probe tip in a horizontal plane so it can sense the airflow passing through it properly. Fully insert the probe so the tip passes through the hole in the airgate approximately 3/32” of an inch. Tighten the retaining collar set screw carefully. Do not over tighten. (*Make sure not to rotate the probe while tightening*).
3. Remove the exhaust transition access panel and place to one side.(*See Figure 1*). Carefully place the cardboard sheet provided on the filter face center. Grasp the airgate with your index finger inserted into the front opening as shown in *Figure 3*. Carefully insert the airgate through the front access opening. Once the airgate is completely inside exhaust transition turn the airgate to the left side of the transition and slowly lower it onto the top seal panel locating the keyhole contour onto the far left weld stud. Insert the #8-32 locknut provided leaving a 1/16 gap between the airgate flange and the lower portion of the nut. Once the Airgate has been installed carefully slide cardboard protector sheet to the right side of the exhaust filter and remove.
4. Run the probe wiring thru the slot located on the left side of the front access opening (*Figure 3*). Re-install the access panel to exhaust transition.
5. If the AFM is not factory installed, attach the AFM box to the cabinet with Velcro material provided and plug its power supply in a wall outlet.
6. **When scanning the exhaust filter for leaks during future certification**, scan the right side of the exhaust filter first, then carefully slide airgate to the right and lift up over weld stud/locknut. There is no need to remove the locknut as long as it is loosened properly. Continue sliding to the right side of the unit in order to scan the remaining left side of the filter. Reverse directions after filter scanning is complete.

AFM Calibration Steps (Low Flow Alarm Condition)

1. Confirm that the cabinet and exhaust system airflow are at the proper set point.
2. For Hard Exhaust Connections (HEC), use the exhaust system damper to lower the exhaust flow until the intake velocity is **80 FPM**.
3. For Canopy Exhaust Connections (CEC) and Exhaust To Room, open the light canopy, locate the cabinet blower motor speed controller and record the voltage across terminals M1 & M2. Reduce voltage to lower the intake velocity to **80 FPM**.

<u>Sash opening</u>	<u>Model</u>	<u>Intake flow rate at 80 FPM</u>
8”	SG 403A	205 CFM
	SG 603A	311 CFM
10”	SG 403A	256 CFM
	SG 603A	389 CFM
12”	SG 403A	306 CFM
	SG 603A	467 CFM

4. Low Flow Alarm Set Point: The ADJUST screw on the AFM box wants to be set so the yellow light will come on, then 6 seconds later the red light will turn on activating the audible alarm. (Make sure the slide switch for the audible alarm

is in the ON position). Turning the alarm ADJUST screw clockwise will move the CFM alarm point up and counter clockwise will move the CFM alarm point down.

5. Return the exhaust system to it proper flow rate and recheck cabinet intake velocity for HEC operation.
6. Return the cabinet blower motor speed controller to it original voltage and recheck cabinet intake velocity for CEC operation.

NOTE: (For either the Exhaust To Room, CEC or HEC connection). If an exhaust transition or cabinet damper adjustment is performed during a routine cabinet certification, the AFM alarm should be recalibrated using the steps above.

Figure 2: Parts Included

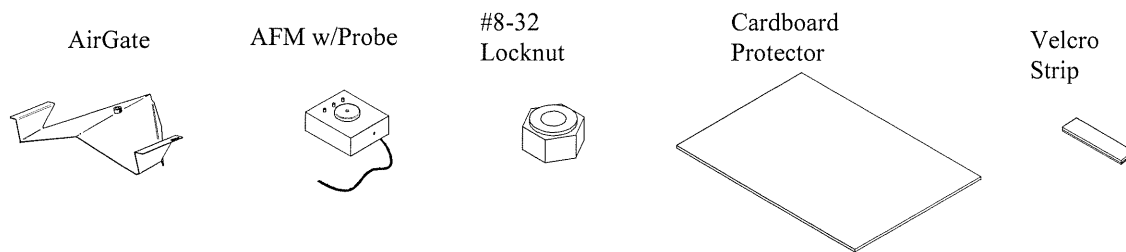
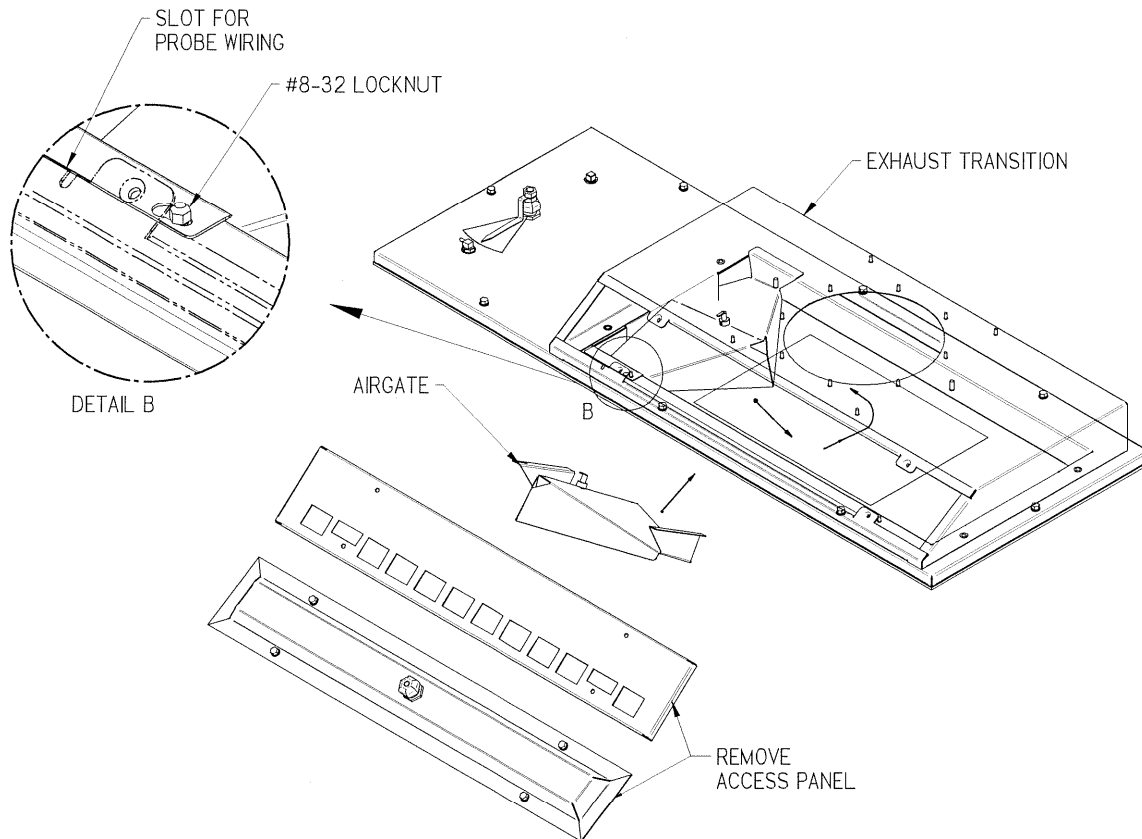

Figure 3: Airgate Installation (HEC or CEC)



NOTICE

The following is an excerpt from the O.S.H.A. Federal Register Page 22240 and Figure J-9.

*Biological hazard signs. The biological hazard warning shall be used to signify the actual or potential presence of a biohazard and to identify equipment, containers, rooms, materials, experimental animals or combinations thereof, which contains, or are contaminated with, viable hazardous agents. For the purpose of this subparagraph the term “biological hazard”, or “biohazard,” shall include only those infectious agents presenting a risk or potential risk to the well-being of man. The biohazard symbol shall be designed and proportioned as illustrated in figure J-9.”

We have enclosed a sign featuring the Biohazard Symbol.

We recommend that you attach this sign to the unit in a prominent location if you plan to perform any work in the hood with agents that present a risk or potential risk to the well-being of man.

Warranty

The Baker Company, Inc. expressly represents and warrants all goods (a) to be as specified (and described) in The Baker Company catalogues and literature, and (b) to be free under normal use, service and testing (all as described in The Baker Company, Inc. catalogues and literature) from defects in material and workmanship from a period of thirty-six months from the invoice date.

The exclusive remedy for any breach or violation of this warranty is as follows: The Baker Company, Inc. will F.O.B. Sanford, Maine furnish without charge repairs to or replacement parts or equipment which proved defective in material or workmanship. No claim may be made for any incidental or consequential damages.

THIS WARRANTY IS IN LIEU OF ALL OTHER WARRANTIES, EXPRESSED OR IMPLIED, INCLUDING ANY IMPLIED WARRANTY OF MERCHANTABILITY OR FITNESS FOR A PARTICULAR PURPOSE UNLESS OTHERWISE AGREED IN WRITING SIGNED BY THE BAKER COMPANY. (THE BAKER COMPANY SHALL NOT BE RESPONSIBLE FOR ANY IMPROPER USE, INSTALLATION, SERVICE OR TESTING OF GOODS

THE BAKER COMPANY

The Baker Company, Inc.
P.O. Drawer E
Sanford, Maine 04073
Tel: (207) 324-8773 / (800) 992-2537
Fax: (207) 324-3869
Email: bakerco@bakerco.com
www.bakerco.com

Copyright©1999 by The Baker Company. All rights reserved.