

Nikon

Inverted Microscope **DIAPHOT 300**

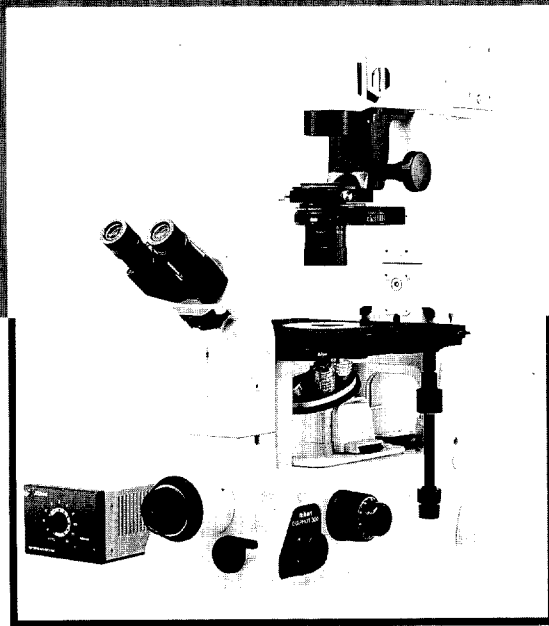

Instructions

NIKON CORPORATION

Thank you for your purchase of Nikon's Inverted Microscope Diaphot 300. Please read this instruction manual thoroughly in order to become acquainted with the complete system and its operation. We hope your Diaphot 300 will be of lasting service.

Nikon reserves the right to make such alterations in design as may be considered necessary in the light of experience. For this reason, particulars and illustrations in this handbook may not conform in every detail to models in current production.

Handling Precautions

1. Handle Carefully!

Handle the microscope gently, taking care to avoid sharp impacts.

2. Purpose

Use the microscope only for microscopic observation. Do not use it for any other applications.

3. Microscope Location

Select a location with limited exposure to dust, vibration, high temperature and humidity (40°C, 80% or more), and direct sunlight. Leave a certain space between the microscope and the nearby wall to allow the user to look at the warning labels on the lamphouse.

4. 12V100W Power Supply Unit

The power supply unit specified on page 53 "ELECTRICAL SPECIFICATIONS" is the power supply unit to light up the Nikon microscopes' 12V100W lamp. Do not use it for other purposes. Also, the user may not use the power supply unit if it is broken, and may not open the cover of the power supply unit.

5. Line Voltage

Confirm that the input voltage to the 12V100W power supply unit corresponds to your line voltage. Be sure to use the specified power supply unit (described in page 53 "ELECTRICAL SPECIFICATIONS").

6. Light Source

The microscope uses a 12V, 100W halogen lamp bulb as the standard light source. Do not use any lamp not described in the "ELECTRICAL SPECIFICATIONS" (on page 53). If a lamp bulb of over-rated wattage is used, the light adjusting circuit may be damaged.

7. With Lamp On —CAUTION—

Do not touch the lamphouse or place any heat-sensitive object near it, since the lamphouse becomes extremely hot during use. Also use great care not to bring volatile substances (such as gasoline, thinner, alcohol, etc.) close to the lamphouse. Such exposure may result in inflammation or other dangers.

8. Replacing the Halogen Lamp

Before replacing the 12V, 100W halogen lamp, turn off the power switch and unplug the power cord. When replacing the halogen lamp, wait until it cools down. Do not touch the glass of the halogen lamp with bare hands.

9. Dirt on Lens

Do not leave dust, dirt or fingerprints on the lens or lamp. Dirt or stains on the lens or mirror will deteriorate image quality.

10. Focusing Knobs

Never attempt to turn the right-hand and left-hand focusing knob in opposite directions at the same time as it will result in defects or damages. An attempt to turn the coarse focusing knob further after it reaches its limit will cause defects or damages. Never turn it forcedly.

Care and Maintenance

1. Lens Cleaning

Dust is best removed with a soft brush or gauze. More persistent dirt, such as fingerprints, grease and oil, may be removed with soft cotton, lens tissue, or gauze lightly moistened with absolute alcohol (methyl alcohol or ethyl alcohol).

Use only xylene to clean immersion oil off objective surfaces.

Do not use xylene to clean the entrance lens at the bottom of the eyepiece tube or prism surface of the eyepiece tube.

Absolute alcohol and xylene are quite inflammable. Use great care when handling them and when setting the power switch on and off. Be very careful with fire.

2. Cleaning Painted Surfaces

Avoid use of any organic solvents (such as alcohol, ether, thinner, etc.) to clean the painted or plastic surfaces of the instrument. We recommend that these parts be cleaned with silicon cloth.

3. Never Dismantle

Never attempt to dismantle the instrument, thereby avoiding the possibility of impaired operational efficiency and accuracy.

4. When Not In Use

When the microscope is not in use, cover it with the vinyl cover, and store it in a dry place not subject to mold.

We especially recommend that the objectives and eyepieces be kept in a container (such as a desiccator) with desiccant in it.

5. Periodical Inspection

To maintain the performance of the microscope, we recommend you to check the microscope periodically. (For details of inspection, contact your dealer or nearest Nikon representative.)

CONTENTS

Handling Precautions
Care and Maintenance

I . NOMENCLATURE	1
II . BASIC MICROSCOPY.....	4
III . PHOTOMICROGRAPHIC PROCEDURE.....	12
IV . OPERATIONS ON COMPONENTS	16
1. ON/OFF switching of power	16
2. Adjusting Brightness	17
3. Changing Optical Paths.....	19
4. Filters	20
5. Field Aperture Diaphragm	21
6. Condenser Aperture Diaphragm	22
7. System Condenser Turret Unit	24
8. Objectives	26
9. Turret Assembly	28
10. Diopter Adjustment.....	29
11. Adjusting Interpupillary Distance	30
12. Photomask.....	31
13. Eyepiece tube	32
14. Focusing Device	33
15. Refocusing Stopper	34
16. Handling Condenser Holder	35
17. Tilttable Illumination Pillar	36
18. Rectangular Mechanical Stage	38
19. Photomicrography	39
V . ASSEMBLY	42
VI . SYSTEM DIAGRAM	48
VII . TROUBLESHOOTING	49
● ELECTRICAL SPECIFICATIONS	53

I . NOMENCLATURE

II . BASIC MICROSCOPY

III . PHOTOMICROGRAPHIC PROCEDURE

IV . OPERATIONS ON COMPONENTS

V . ASSEMBLY

VI . SYSTEM DIAGRAM

VII . TROUBLESHOOTING

● ELECTRICAL SPECIFICATIONS

I . NOMENCLATURE

1. System Components (Right-hand)

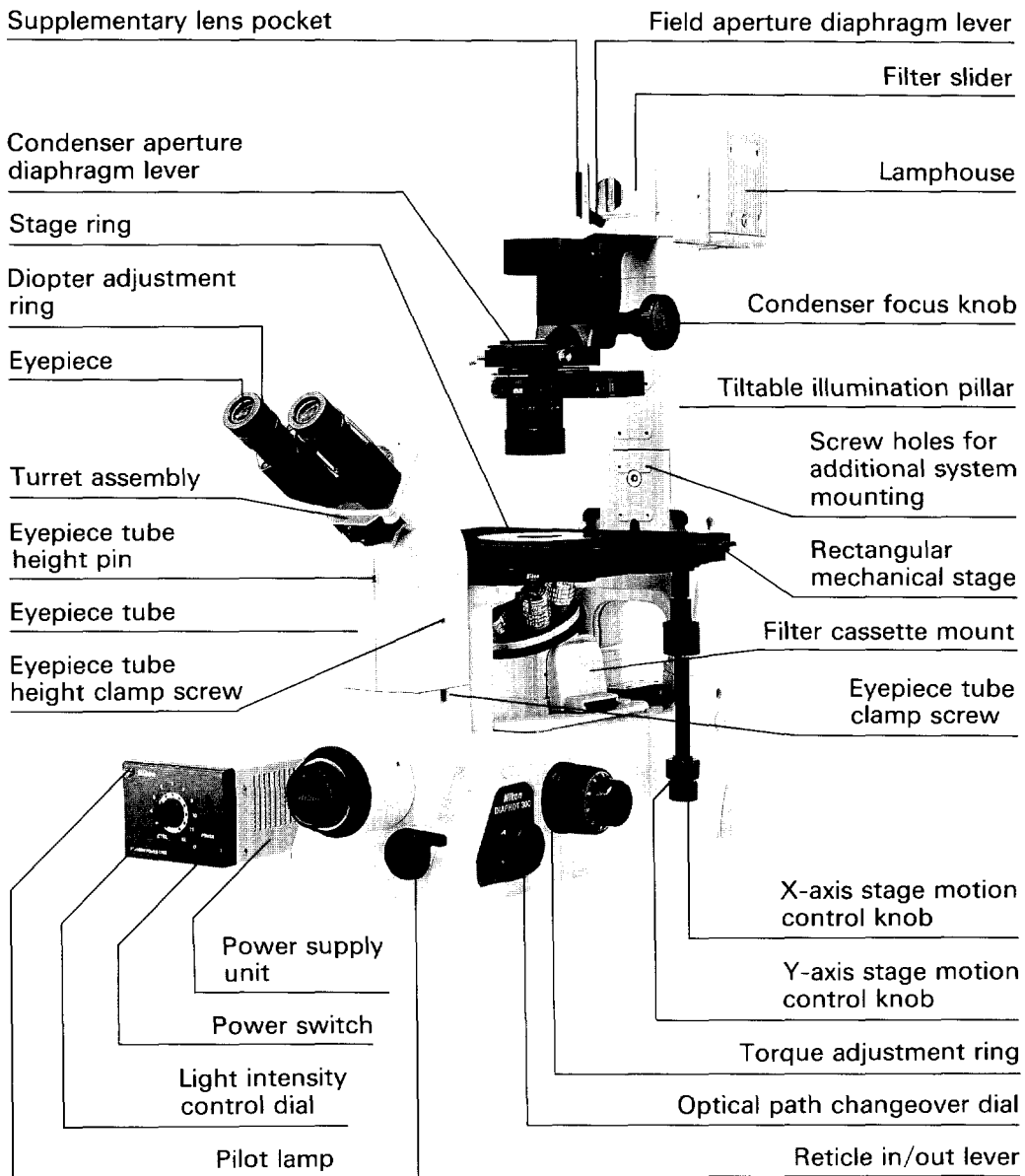

Figure 1-1

2. System Components (Left-hand)

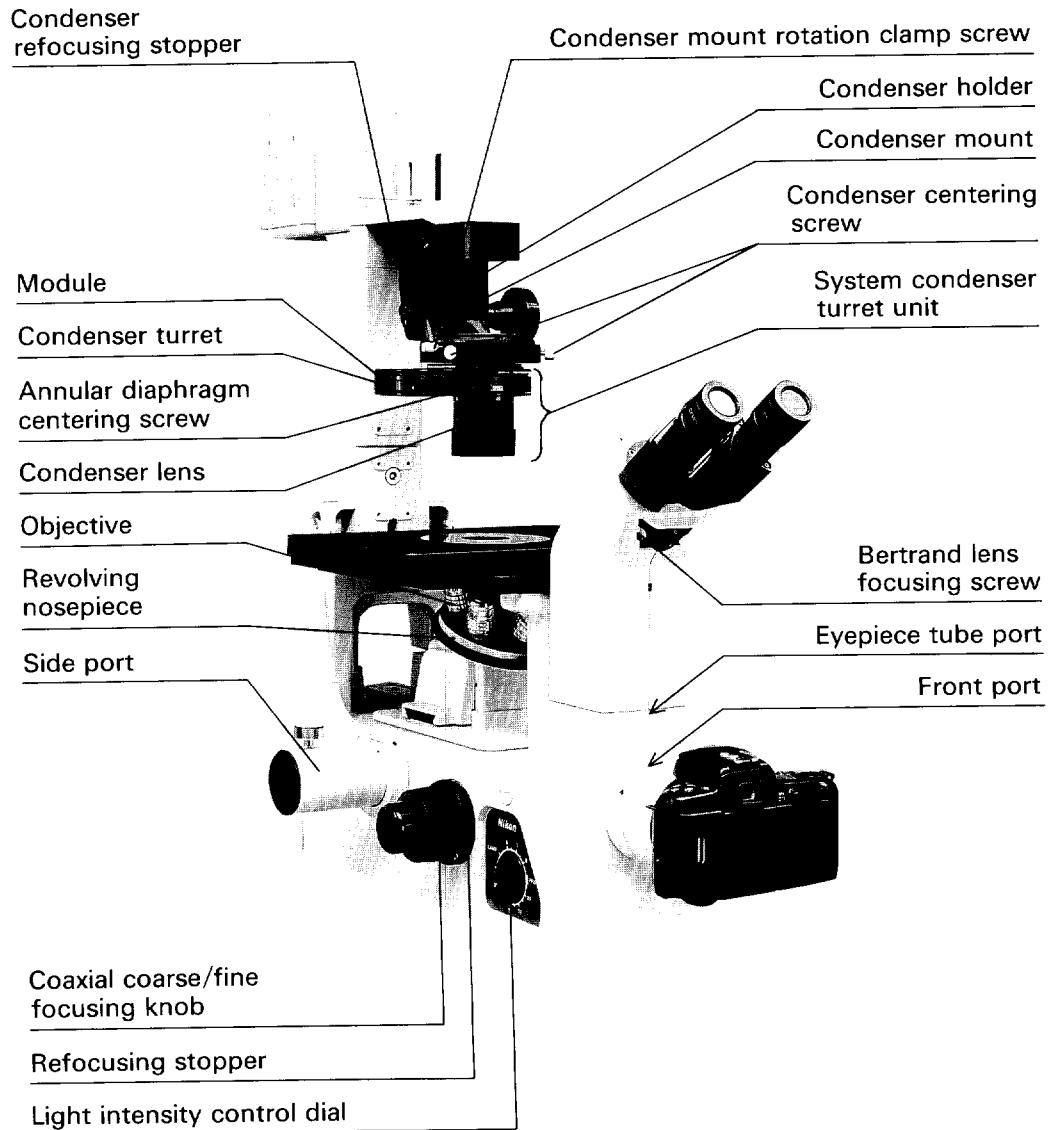

Figure 1-2

3. System Components (Rear)

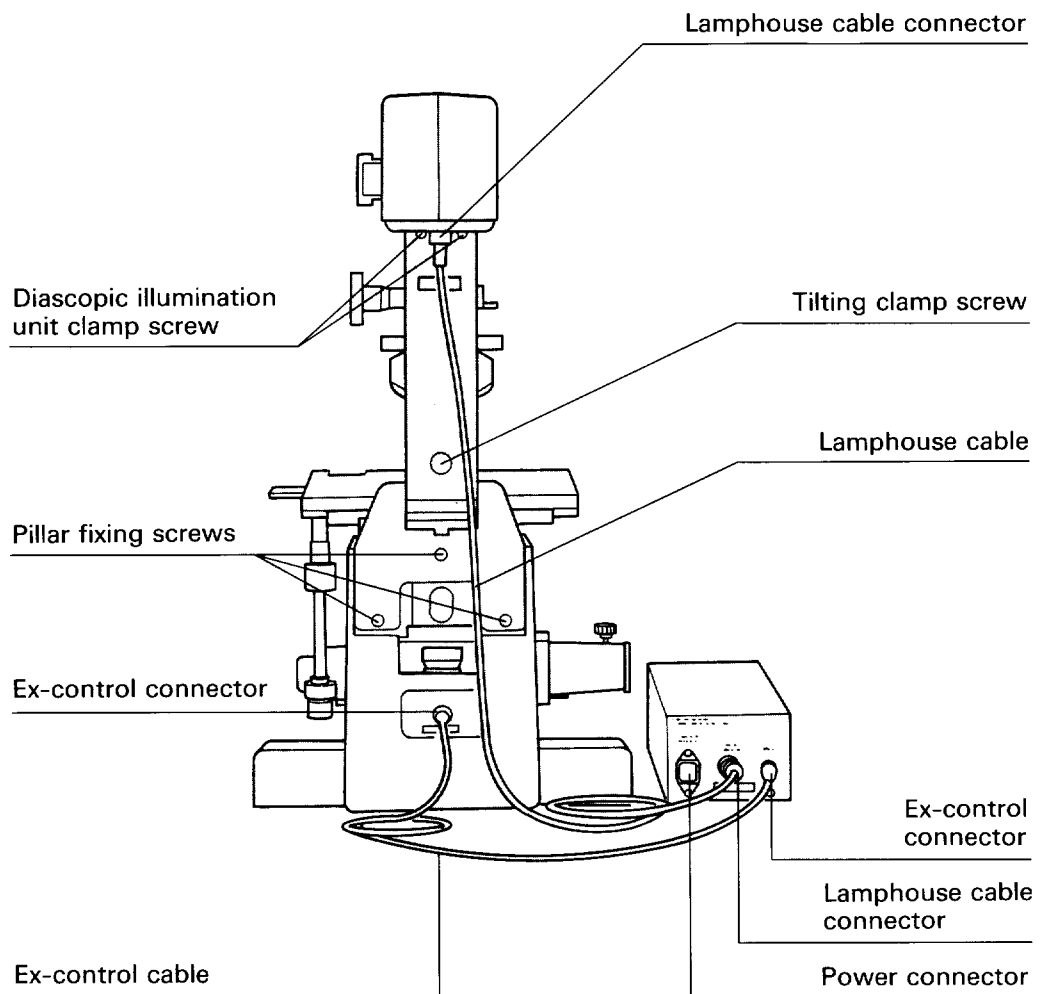

Figure 1-3

II. BASIC MICROSCOPY

For the normal microscopy, carry out steps 1. to 14. For phase contrast microscopy, carry out steps 1. to 18. For detailed operations, see Section IV. "OPERATIONS ON COMPONENTS", from page 16.

If the microscope has not been assembled, first read Section V. "ASSEMBLY" from page 42.

1. Turn on the power.

After confirming that the power supply is set for the correct line voltage, turn on the power switch. Set the light intensity control dial on the power supply unit to CTRL.

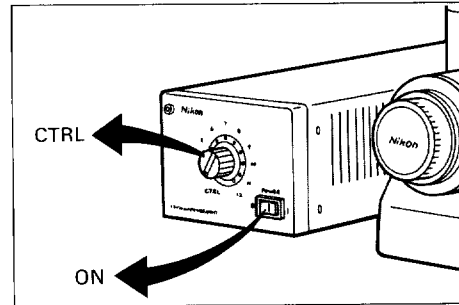

Figure 2-1

2. Set the lamp voltage to 6.

Rotate the light intensity control dial on the left side of the base to the "6" position. (If the light intensity is too high or too low, adjust it properly.)

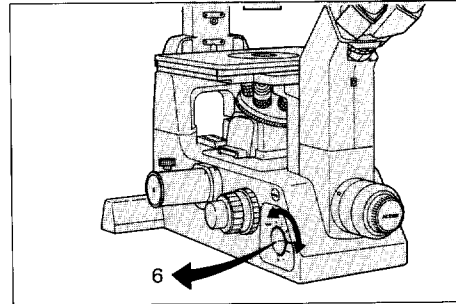

Figure 2-2

3. Set the optical path for the observation.

Set the turret assembly to O. (Eyepiece tube BT1 only.)

Set the optical path changeover dial on the right side of the base to A.

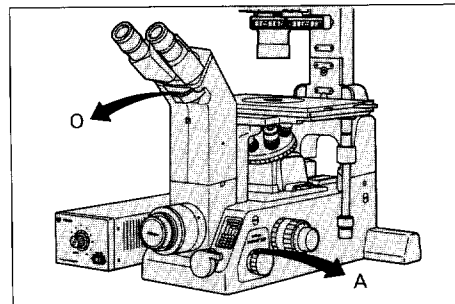

Figure 2-3

4. Select the NCB11 filter.

Hold the nonslip portion of the filter slider to push in the NCB11 filter. Do not touch the filter. Keep other filters out of the optical path. For phase contrast microscopy, set the GIF (green interference) filter, instead of the NCB11 filter, in the optical path.

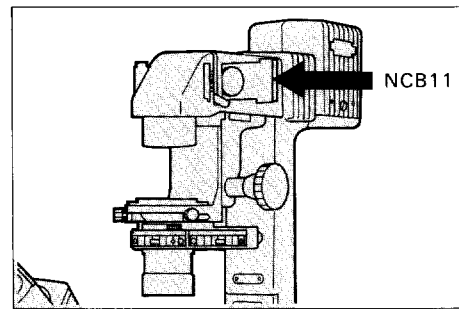

Figure 2-4

5. Fully open the field aperture and condenser aperture diaphragms.

Raise the field aperture diaphragm lever. Turn the condenser aperture diaphragm lever to the right.

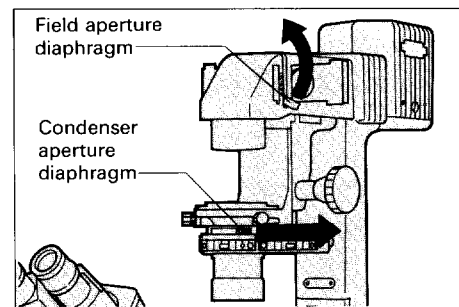

Figure 2-5

6. Adjust the condenser position.

Adjust the condenser to an approximately correct position.

- System condenser turret unit

- ◆ LWD condenser

- Rotate the condenser refocusing stopper by half turn to loosen it, and rotate the condenser focus knob to lower the condenser to its limit. Rotate the turret until the module A comes to the front (i.e., it enters the optical path).

- ◆ ELWD condenser

- Rotate the condenser focus knob to raise the condenser to the upper limit, then lower the condenser by approx. 1cm from the limit. Rotate the turret until the module A comes to the front (i.e., it enters the optical path).

- ELWD condenser

- Rotate the condenser focus knob to raise the condenser to the upper limit, then lower the condenser by approx. 2cm from the limit.

- SLWD condenser

- The SLWD condenser requires no adjustment since it is fixed.

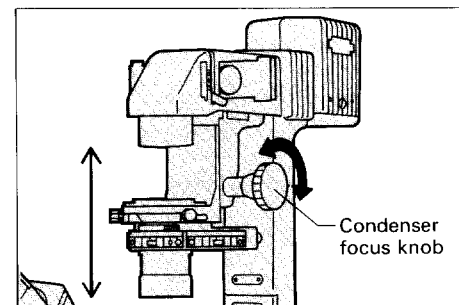

Figure 2-6

7. Move the 10× objective into the optical path.

Move the 10× objective into the optical path by rotating the revolving nosepiece securely into the clickstop.

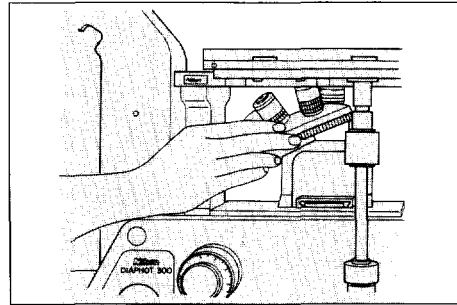

Figure 2-7

8. Adjust the eyepiece diopter.

Turn down the reticle in/out lever to the right to bring the photomask into the optical path.

Rotate the diopter adjustment ring on each eyepiece to bring the photomask's double crosshairs into sharp focus. (Be sure to perform this step for each eye, as correct focus for each eye is usually different.)

If the optional rubber eye guards are used and if you wear glasses, fold down the rubber eyeguards.

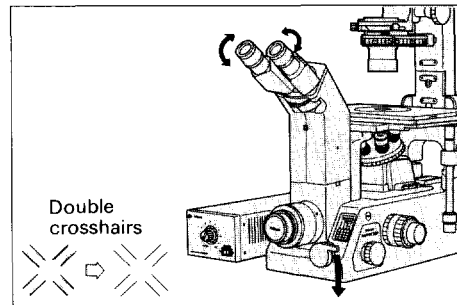
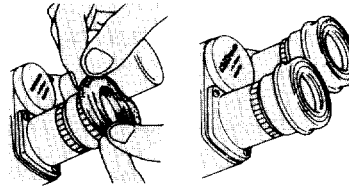

Figure 2-8



9. Adjust the interpupillary distance.

Adjust the interpupillary distance until the viewfield is visible as a single image through both eyepieces.

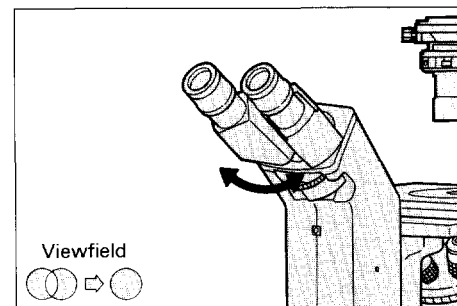

Figure 2-9

10. Place a specimen on the stage.

If the specimen is on a slide glass, be sure to mount it with its cover glass facing down. (See page 27.) Move the stage to position the desired section of the specimen into the viewfield.

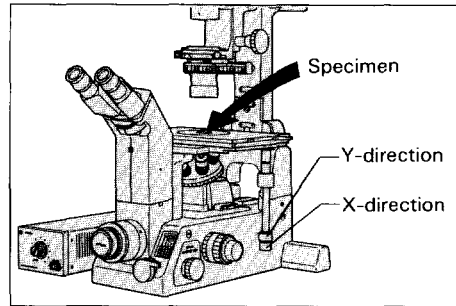

Figure 2-10

11. Focus.

Rotate the refocusing stopper on the left-hand focusing knob counter-clockwise to unlock the stopper. Rotate the coarse/fine focusing knob to focus on the specimen.

NOTE: Never turn the left-hand and right-hand knobs in the opposite directions at the same time, as damage may result.

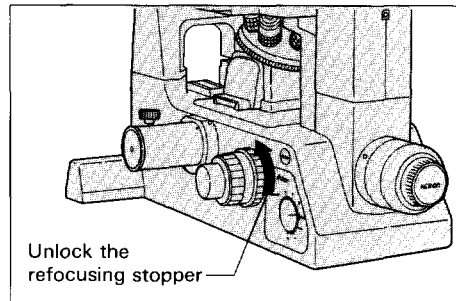

Figure 2-11

12. Center the condenser.

Narrow down the field aperture diaphragm until the diaphragm edge is viewed through eyepieces. Rotate the condenser focus knob to focus the image of the field aperture diaphragm on the specimen surface. Adjust the condenser centering screws so that the center of the field aperture diaphragm image matches the center of the viewfield.

NOTE: If the SLWD condenser is used, this centering is unnecessary. (Fully open the field aperture diaphragm.)

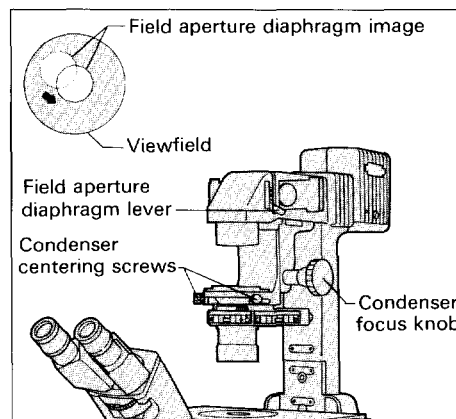

Figure 2-12

13. Switch to the 40× objective and re-center the condenser.

Switch to the 40× objective.
Adjust the image of the field aperture diaphragm until it is circumscribed with the viewfield.
If the center of the field aperture diaphragm image is off the center of the viewfield (eccentric condition), readjust with the condenser centering screws.
If the LWD condenser is used, tighten the condenser refocusing stopper.

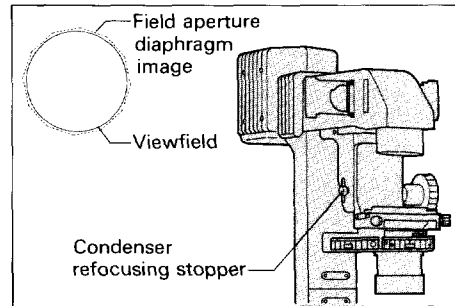

Figure 2-13

14. Perform microscopy with a desired objective

- ◆ Switch to a desired objective.
- ◆ Focus the microscope.
- ◆ Adjust the field aperture diaphragm until it is inscribed or circumscribed with the viewfield.
- ◆ Adjust the brightness with the ND filters or the light intensity control dial on the base. (Maintain the lamp voltage between 6 and 12. For color photomicrography, adjust it to PHOTO. See page 17.)
- ◆ Stop down the condenser aperture diaphragm to a range of 70 to 80% of the objective's numerical aperture. (See page 22.)
- ◆ When replacing the specimen, you can use the refocusing stopper (page 34), condenser refocusing stopper (page 35), and pillar tilting mechanism (page 36) for enhanced efficiency.

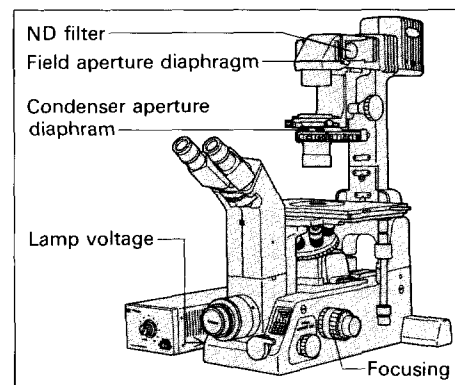

Figure 2-14

Now, the basic microscopic operation is completed.
Improved image quality may be achieved by slightly opening or closing the condenser aperture diaphragm. (See page 22.)
For phase contrast microscopy, proceed with the following steps 15. to 18.

Phase Contrast Microscopy

15. Switch to the phase contrast objective.

Rotate the revolving nosepiece to bring the phase contrast objective of the lowest magnification (ex. 4×) into the optical path. Focus the microscope with the coaxial coarse/fine focusing knob. (The phase contrast objective is identified as it is impressed with the Ph code. See page 26.)

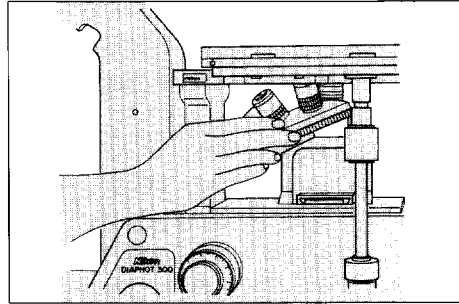

Figure 2-15

16. Bring the phase annular diaphragm into the optical path.

Identify the annular diaphragm that has the same Ph code as marked on the objective now in the optical path, and bring it into the optical path. (If the system condenser turret unit is used, rotate the turret to bring the module having the same Ph code as marked on the objective into the optical path.)

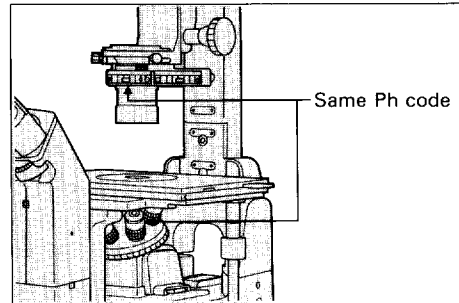

Figure 2-16

17. Center the annular diaphragm.

Open the field aperture diaphragm to the full.

If BT1 eyepiece tube is used:

Set the turret assembly to B. While observing through both eyepieces, rotate the Bertrand lens focusing screw to focus on the phase plate image of the objective and the annular diaphragm image of the condenser.

If BT2 eyepiece is used:

Remove an eyepiece and insert the centering telescope in place. Holding the knurled part of the centering telescope, rotate its eyepiece to focus on both the phase plate image of the objective and the annular diaphragm image of the condenser.

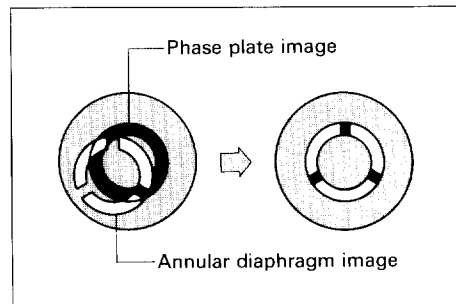

Figure 2-17

Adjust so that the phase plate image is concentric with the annular diaphragm image. Note that since any displacement of the phase plate and annular images will cause low contrast to the phase contrast image of the specimen, the exact coincidence of the two images is necessary.

- System condenser turret unit
Open the condenser aperture diaphragm to the full. (The optical path is blocked if the condenser aperture diaphragm is narrowed.) Insert two hexagonal screwdrivers into the annular diaphragm centering screws of the module in the optical path, and rotate the screwdrivers to center the annular diaphragm.

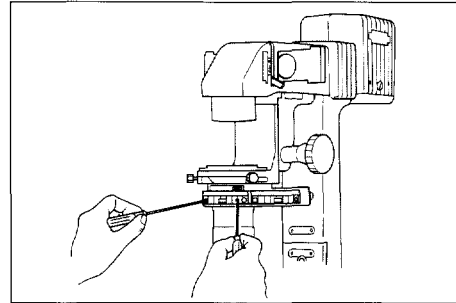

Figure 2-18

- ELWD condenser
Unclamp the right-hand and left-hand turret centering knobs. Rotate the centering knobs for adjustment. Through PhL centering, other annular diaphragms are also centered automatically.

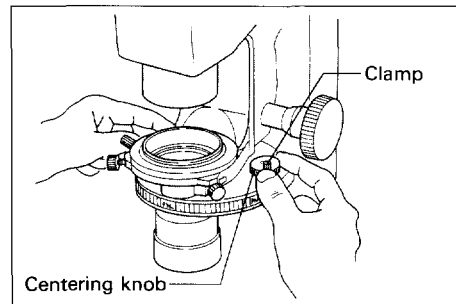

Figure 2-19

- SLWD condenser
Bring the PhL annular diaphragm into the optical path, then rotate the centering screws for adjustment. Maintain the field aperture diaphragm fully opened during observation. (No centering adjustment is necessary for the Ph1 annular diaphragm since it is fixed.)

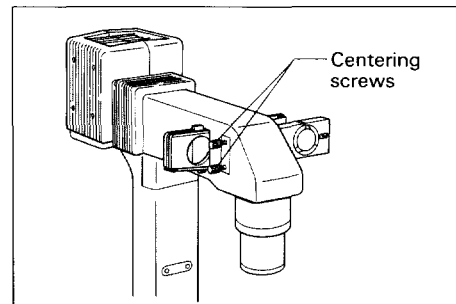

Figure 2-20

18. Perform microscopy with a desired phase contrast objective.

- Use the annular diaphragm (module) that has the same Ph code as marked on the objective on the optical path. Every time the annular diaphragm (module) is changed, center the annular diaphragm as described in 17. (As for the ELWD condenser, once centering is complete with PhL, other annular diaphragms are also centered automatically.)
- Adjust the field aperture diaphragm until it is circumscribed with the viewfield. (Open it to the full for the SLWD condenser)
- Adjust the brightness with the ND filters or the light intensity control dial.
- If the system condenser turret unit is used, always open the condenser aperture diaphragm to the full.
- For microscopy at the maximum contrast, bring the GIF filter into the optical path. Keep the NCB11 filter away from the optical path when using GIF filter.
- When replacing the specimen, you can use the refocusing stopper (page 34), condenser refocusing stopper (page 35), and pillar tilting mechanism (page 36) for enhanced efficiency.

Now, the phase contrast microscopic operation is all completed.

When you observe a specimen in a laboratory dish or other containers, we recommend the use of an objective that has a correction ring for compensating the thickness of the dish or container bottom. (See page 26.)

III. PHOTOMICROGRAPHIC PROCEDURE

Nikon's 35mm single-lens reflex cameras (such as F-601) and photomicrographic attachment MICROFLEX Series (option) may be used for photomicrography with the Diaphot 300.

Mount an SLR camera directly on the microscope front port. Because intermediate magnification, $2.5\times$, is applied, the photomicrography magnification is the "magnification of the objective multiplied by 2.5". The use of a cable release (option) eliminates the effects of vibration, allowing efficient photomicrography.

Mount a photomicrographic attachment directly on the side port, or on the eyepiece tube port via the optional eyepiece tube bracket and the trinocular eyepiece tube for the upright type microscope (option).

The following shows the photomicrographic procedures using a 35 mm SLR camera.

Before starting photomicrography, make sure that:

- The microscope is ready for normal microscopy. (See page 4.)
- The camera is loaded with film. (Refer to the instruction manual that comes with your camera.)
- ◆ For the photomicrographic procedures using the photomicrographic attachment, refer to its manual. Rotate the optical path changeover dial to align the optical path to the port on which the photomicrographic attachment is mounted.
- ◆ Regarding the procedure for mounting a camera or photomicrographic device, see Section V. "ASSEMBLY", from page 42.
- ◆ For detailed operations with individual components, see Section IV. "OPERATIONS ON COMPONENTS", from page 16.

1. Turn on the camera.

Flip on the main switch of the camera. Set the camera for the appropriate film sensitivity, exposure mode, and photometry mode. (Refer to the instructions supplied with the camera.)

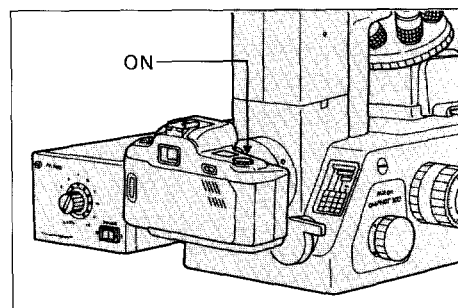

Figure 3-1

2. Adjust lamp voltage to PHOTO.

Set the light intensity control dial on the left side of the base to PHOTO. (page 17) (If the light intensity control dial on the power supply unit is used, set near "9".)

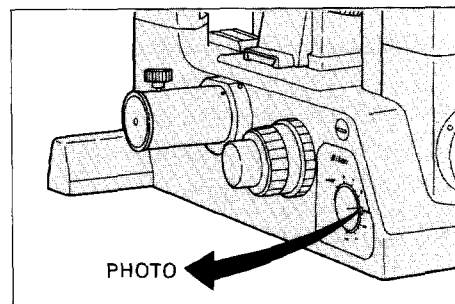

Figure 3-2

3. Select the optical path for photomicrography.

Set the turret assembly to O. (This applies to the eyepiece tube BT1 only.)
Set the optical path changeover dial on the right side of the base to B.

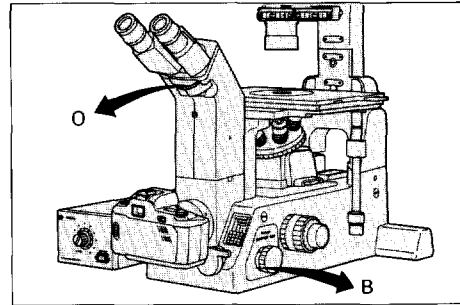

Figure 3-3

4. Set the filters.

- Daylight type color film: Bring the NCB11 filter into the optical path.
- Monochrome film or tungsten type color film: Bring the NCB11 filter out of the optical path.

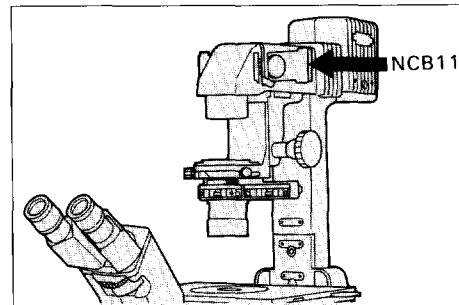

Figure 3-4

5. Compose the frame.

Turn down the reticle in/out lever to the right to bring the photomask into the optical path.

Move the stage to bring the desired object inside the photomask. (page 39)

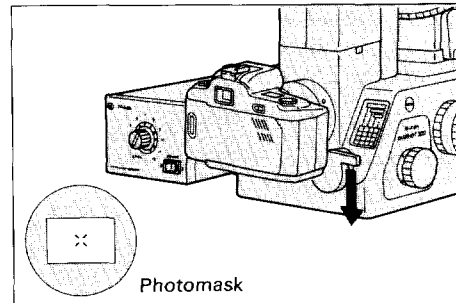

Figure 3-5

6. Adjust the focus.

While observing through the eyepieces, focus on your specimen. (page 40)

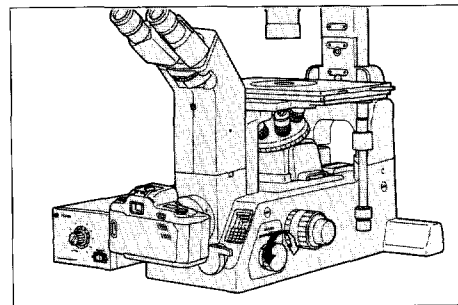

Figure 3-6

7. Adjust the diaphragm.

Narrow the field aperture diaphragm until it is slightly wider than the area to be photomicrographed. Adjust contrast, depth of focus and resolution with the condenser aperture diaphragm. (This diaphragm should usually be set to a range of 70 to 80% of the objective's numerical aperture. See page 22.)

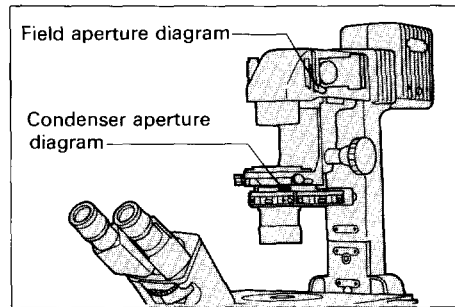

Figure 3-7

8. Check the exposure time.

Check the exposure time displayed on the camera. Adjust the brightness so that the exposure time is longer than 1/8 of a second.

- Color film: Adjust with the ND filters. (Keep the NCB11 filter in the optical path.)
- Monochrome film: Adjust with the ND filters or by varying the lamp voltage.

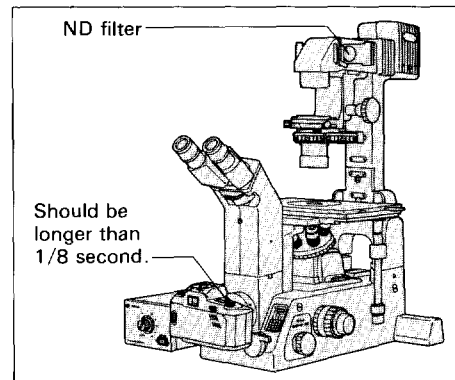

Figure 3-8

9. Prevent external light from coming in.

Fit the finder cap (option) to the camera finder. (Keep the finder cap on the finder except when the exposure time should be checked through the finder.) Set the turret assembly to C. (This applies to the eyepiece tube BT1, especially for long-time exposure.)

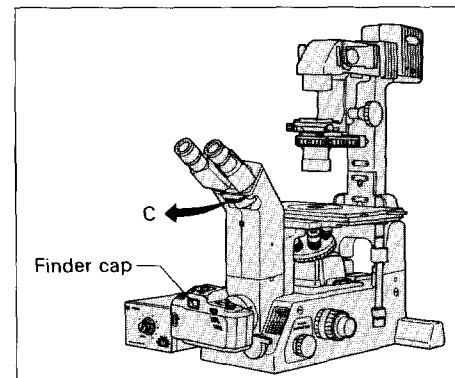

Figure 3-9

10) Press the shutter.

If the cable release (option) is used, press the release button.
The self-timer of the camera enables vibration-free photomicrography.

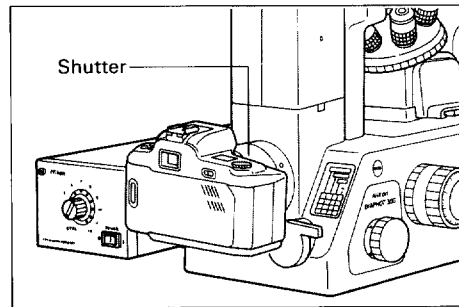

Figure 3-10

NOTE

The following requirements are especially important for photomicrography. Read the corresponding pages.

- The lighting is proper. (See page 39.)
- The microscope is accurately focused. (See page 40.)
- External light is kept out. (See page 39.)

IV. OPERATIONS ON COMPONENTS

1. ON/OFF switching of power

NOTE

- Before turning the power on, make sure that the input voltage to the power supply unit corresponds to the available line voltage.
- The microscope uses a 12V, 100W halogen lamp bulb as the standard light source. Do not use any other lamps. (See page 53.) If a lamp bulb of over-rated wattage is used, the light intensity adjusting circuit may be damaged.
- –CAUTION– Do not touch the lamphouse or place any heat-sensitive object near it, since the lamphouse becomes extremely hot during use. Also use great care not to bring volatile substances (such as gasoline, thinner, alcohol, etc.) close to the lamphouse. Such exposure may result in inflammation or other dangers.

Connect the power supply unit and lamphouse with the lamphouse cable.

To turn the power on, turn the power switch on the power supply unit front panel to the "1" position. The lamp goes on. (At this time, the pilot lamp on the power supply unit front panel also goes on.)

To turn the power off, turn the power switch to the "0" position. The lamp goes out. (The pilot lamp on the power supply unit also goes out.)

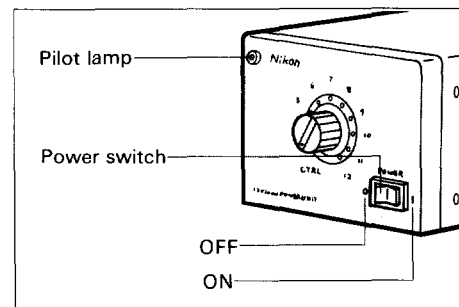

Figure 4-1

2. Adjusting Brightness

Control the lamp voltage or use the ND filters to adjust the brightness.

1) Brightness adjustment by controlling the lamp voltage

Two light intensity control dials are available: one on the front panel of the power supply unit, the other on the left side of the microscope base. Either of them can be used for brightness control.

Connect the microscope and power supply unit with the ex-control cable, and set the light intensity control dial on the power supply unit to CTRL. Now, light intensity can be adjusted with the light intensity control dial on the microscope body.

- If the light intensity control dial on the power supply unit is not set to CTRL, the light intensity control dial on the microscope body does not function.
- The light intensity control dial on the power supply unit and that on the microscope provide slightly different light intensity at the same readings.
- As the lamp voltage is changed, the color temperature also varies, which results in blueish hues if the dial volume is set to high numbers and reddish hue if set to low. For photomicrography using daylight type color film, be sure to set the lamp voltage to PHOTO or around 9 and bring the NCB11 filter into the optical path for the best color balance. (See page 20.)
- For photomicrography using tungsten type color film, set the lamp voltage to 8 and keep the NCB11 filter away from the optical path.
- For photomicrography using monochrome film, set the lamp voltage to 6 or higher and keep the NCB11 filter away from the optical path.
- Normally, adjust the lamp voltage between 6 and 12.

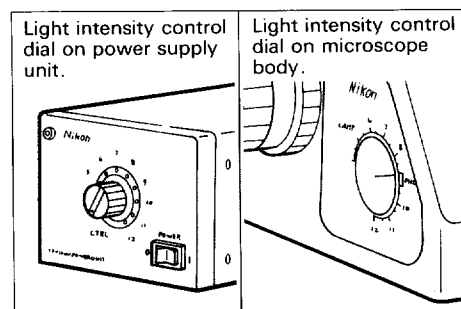

Figure 4-2

2) Brightness adjustment with ND filters

Filters for controlling light quantity are called ND filters. ND filters having larger numbers provide less transmission and therefore darker images. For color film, light quantity is controlled with ND filters, not by varying the lamp voltage.

This is because the change of lamp voltage leads to the change of color temperature which greatly effects the photomicrography.

ND filters are to be attached to the filter slider at the diascopic illumination unit. (See page 43.)

ND2 : Reduces light quantity to 1/2.
(Approx. 50% transmissivity)

ND16: Reduces light quantity to 1/16.
(Approx. 6% transmissivity)

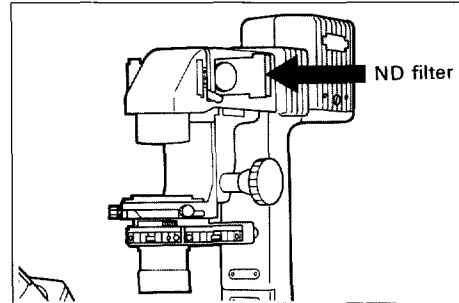

Figure 4-3

3. Changing Optical Paths

This microscope has three ports; the eyepiece tube port (circular dovetail groove) for mounting the eyepiece tube, the front port (F mount) for mounting a 35mm SLR camera, and the side port (C mount) for mounting a photomicrographic attachment or any other devices. Use the optical path changeover dial on the right side of the microscope base to switch the optical paths between these ports.

- Only the front port has 2.5 × intermediate magnification.
- The eyepiece tube for the erect type microscope and any other devices may be mounted on the eyepiece tube port by using the eyepiece tube bracket (option). (For example, a teaching head or drawing tube may be mounted.)
- Various devices may be mounted to the side port. The mounting may be direct, or indirect via the C-mount adapter. (For example, a photomicrographic attachment, TV system, or photometry system may be mounted.)

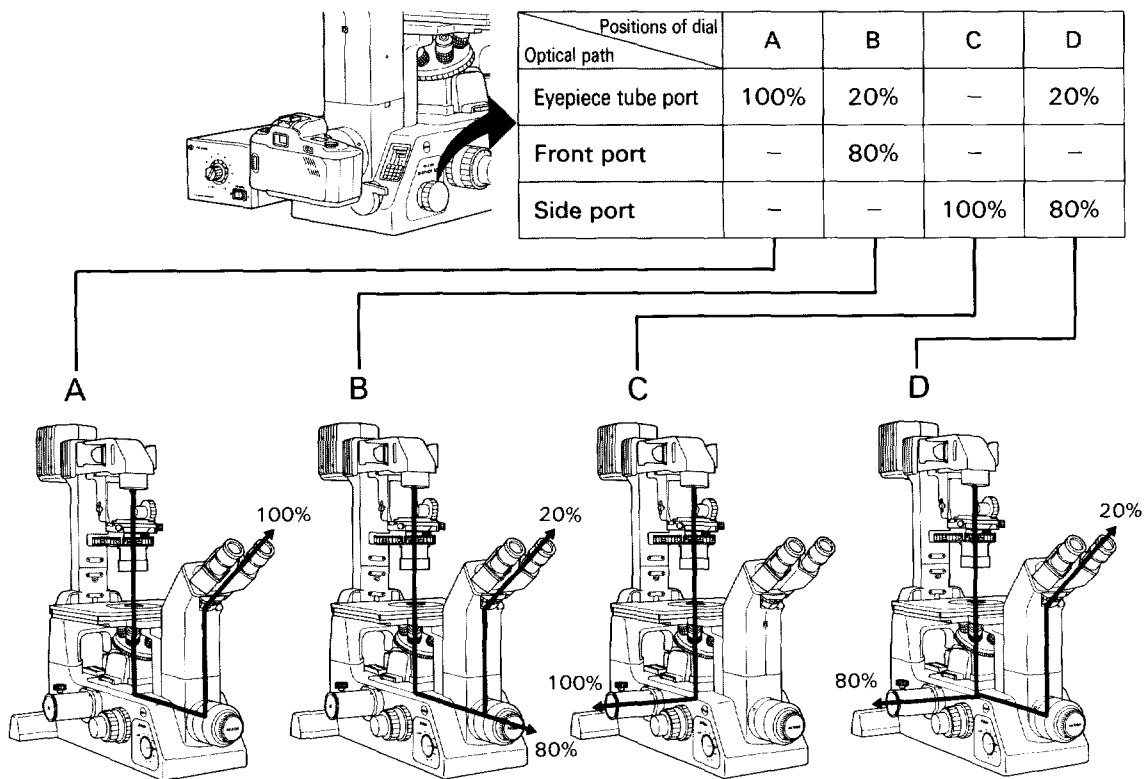

Figure 4-4

4. Filters

Set the appropriate filters in three filter sliders at the diascope illumination unit. (See page 43.)

The following filters are available.

- ND2 filter : For normal microscopy and for brightness adjustment in photomicrography. Reduces light quantity to 1/2. (Approx. 50% transmissivity)
- ND16 filter : For normal microscopy and for brightness adjustment in photomicrography. Reduces light quantity to 1/16. (Approx. 6% transmissivity)
- NCB11 filter : For normal microscopy and for correcting the color temperature in color photomicrography (day light type). The color reproducibility is maximized when the NCB11 filter is brought into the optical path and the lamp voltage is set to PHOTO. (Coloring delicately differs with film brands.) The NCB11 filter should be kept away from the optical path when making photomicrography with tungsten type color film or monochrome film.
- GIF filter : Green interference filter. For microscopy with monochromatic light and for improving the contrast in monochrome photomicrography.
- Heat insulation filter: For reducing the influences of heat rays in the illumination light on the sample. Use the heat insulation filter for a sample quite sensitive to heat, though the microscope has a built-in heat insulation filter.

5. Field Aperture Diaphragm

The field aperture diaphragm restricts the illumination on a specimen to within an observation area. The diameter of the field aperture diaphragm is maximized by setting the field aperture diaphragm lever to the top position.

For general use, the diaphragm is set slightly larger (or smaller) than the viewfield. Too wide an illuminated area gives off stray light, which causes flares, resulting in reduced image contrast.

Therefore, correctly adjust the field aperture diaphragm, especially in photomicrography. In general, good results are produced by stopping down the diaphragm slightly wider than the film format. (Too much stopping down causes vignetting.)

NOTE

Keep the field aperture diaphragm fully opened when the SLWD condenser is used for phase contrast microscopy.

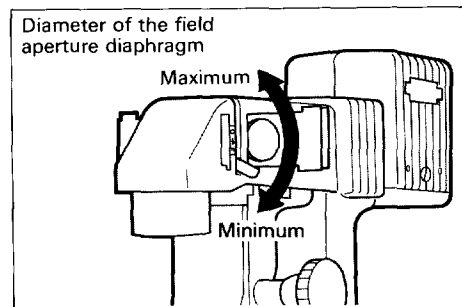

Figure 4-5

6. Condenser Aperture Diaphragm

The condenser aperture diaphragm adjusts the numerical aperture (N.A.) of the illumination system. Aperture of this diaphragm determines optical resolution, brightness, contrast, and depth of focus.

Narrowing down the condenser aperture diaphragm decreases resolution and brightness, and increases contrast and depth of focus. Because these characteristics are interrelated and cannot be controlled one by one, the aperture must be adjusted for each specimen and application.

Adjustment of the condenser aperture diaphragm is especially important for bright-field microscopy, differential interference microscopy, and photomicrography. Generally, aperture settings of 70 to 80% of the objective N.A. yield good images of appropriate contrast.

Adjust the aperture of the diaphragm while observing the diaphragm image through the eyepieces. Leftward rotation of the condenser aperture diaphragm lever stops down the diaphragm. Rightward rotation opens it.

For eyepiece tube BT1:

Set the turret assembly to B to bring the Bertrand lens into the optical path, then adjust the focus with the Bertrand lens focusing screw. The images of the objective's exit pupil (bright circle) and condenser aperture diaphragm become visible. (If the image of the condenser aperture diaphragm is not seen, stop down the condenser aperture diaphragm further.) While observing these images, adjust the condenser aperture diaphragm lever until the aperture of the diaphragm reaches 70 to 80% of the exit pupil of the objective.

For eyepiece Tube BT2:

Remove one eyepiece, then insert the centering telescope. Hold the knurled ring of the centering telescope by one hand and rotate its eyepiece for focusing. The images of the objective's exit pupil (bright circle) and condenser aperture diaphragm become visible. (If the image of the condenser aperture diaphragm is not seen, stop down the condenser aperture diaphragm further.) While observing these images, adjust the condenser aperture diaphragm lever until the aperture of the diaphragm reaches 70 to 80% of the exit pupil of the objective.

NOTE

- Be sure to keep the condenser aperture diaphragm fully opened when the system condenser turret unit is used for phase contrast microscopy. (With the condenser aperture diaphragm stopped down, the optical path is blocked.)
- Since the condenser aperture diaphragm of the ELWD condenser is independent from annular diaphragm, its size will not have any effect on the annular diaphragm.
- There is no condenser aperture diaphragm on SLWD condenser.

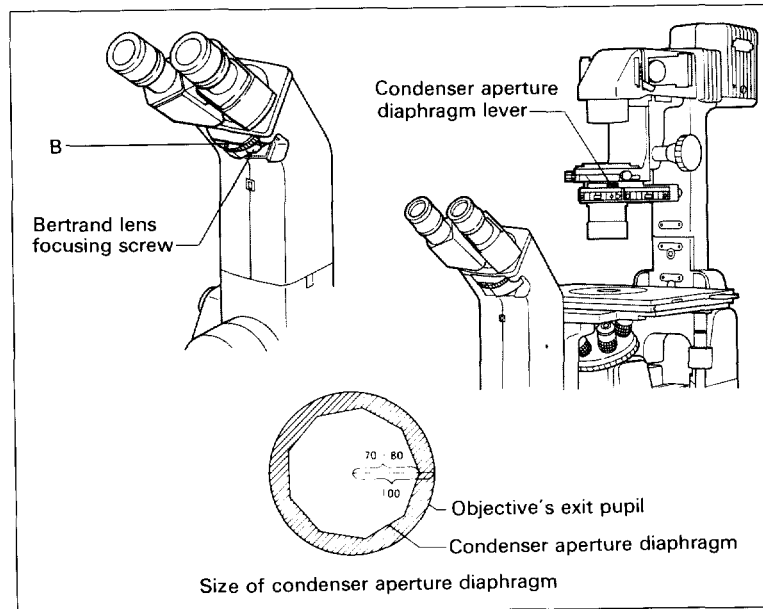

Figure 4-6

7. System Condenser Turret Unit

A condenser has dual functions. It condenses light, and provides the condensed light with optical elements to enable various types of microscopic applications. Traditional microscopes require condensers to be changed according to microscopic applications: for example, a phase contrast condenser for phase contrast microscopy, and a differential interference condenser for differential interference microscopy.

The system condenser turret unit of this microscope features modules that contain optical elements; up to five modules can be built in the unit. The user need only to rotate the turret to execute various microscopic applications without changing condensers. Modules may be replaced without dismounting the condenser turret unit from the microscope, enabling several microscopic applications to be executed for a short period of time.

- Modules may be arranged freely in the turret unit if they are applicable to the condenser lens in use.
- For phase contrast microscopy, select the module having the same Ph code as marked on the objective and bring it into the optical path and center the annular diaphragm. (See page 9.)
- Be sure to keep the condenser aperture diaphragm fully opened when the system condenser turret unit is used for phase contrast microscopy. (With the condenser aperture diaphragm stopped down, the optical path is blocked.)

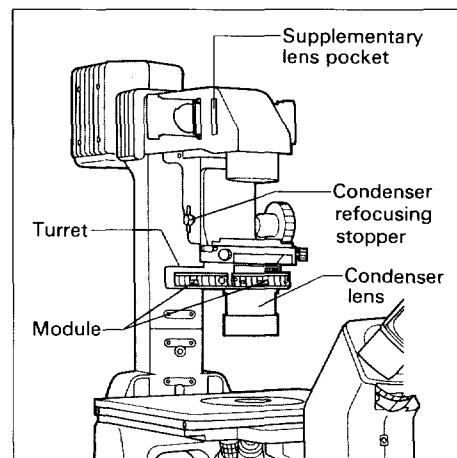

Figure 4-7

● **LWD Condenser (with supplementary lens)**

This condenser features a long working distance (30mm), with N.A. of 0.52. It is capable of phase contrast, differential interference, and bright-field microscopy applications. The condenser is used with its supplementary lens installed in the pocket at the diascope illumination unit. The condenser refocusing clamp can be used. (See page 35.)

The following modules can be used with this condenser:

For phase contrast microscopy : PhL, Ph1, Ph2, Ph3, Ph4

For differential interference microscopy: DICO.5 (NL), DICO.5-1.0 (NM)

For bright-field microscopy : A

NOTE

Be sure to set the supplementary lens in the pocket at the diascope illumination unit for maximum performance.

● **ELWD Condenser**

This condenser features a very long working distance (75mm), with N.A. of 0.3. It is capable of phase contrast, differential interference, and bright-field microscopy applications.

The following modules can be used with this condenser:

For phase contrast microscopy : PhL, Ph1, Ph2, Ph3

For differential interference microscopy: DICO.5 (NL)

For bright-field microscopy : A

NOTE

Check whether the LWD condenser supplementary lens is not left in the pocket at the diascope illumination unit. If it is left, replace it with a hollow slider.

8. Objectives

1) Ph Codes

Each phase contrast objective is labeled a Ph code: PhL, Ph1, Ph2, Ph3, or Ph4. For phase contrast microscopy, be sure to use the annular diaphragm or module having the same Ph code as marked on the objective, regardless of the objective magnification.

2) Objective with correction ring

An inverted microscope is frequently used to observe specimens through the bottom plate (made of glass or plastic) of a laboratory dish or culture bottle. For such applications, the normal objectives (for 0.17mm thick cover glass) may not provide clear images, disabling the microscope from demonstrating its full performances. In such cases, use an objective with a correction ring to compensate for bottom plate thickness.

NOTE

The objectives with correction rings are not intended to compensate for wedge-like changes of thickness at edges of a container. We recommend that they should be used for compensation for even thickness.

● Adjusting the correction ring

- (1) Adjust the scale of the correction ring to the thickness of the bottom plate of the container. This thickness should be a measured value or the value stated by the container manufacturer.
- (2) Focus on the specimen with the coaxial coarse/fine focusing knob.
- (3) Rotate the correction ring clockwise or counterclockwise slightly if the image has poor resolution and/or contrast. When the correction ring is rotated, the specimen image becomes slightly out of focus. Adjust the focus again with the fine focusing knob.
- (4) If the resolution and contrast are improved, rotate the correction ring further in the same direction, then adjust the focus again.

If the resolution and contrast are deteriorated, rotate the correction ring in the reverse direction by the amount about double the previous turn, then adjust the focus.

In this way, rotate the correction ring in the same direction if a better image is obtained, or rotate it in the reverse direction if a poor image is obtained.

Repeat this operation to find the best point.

- ◆ The Omm position of the correction ring is used for microscopy of a specimen with no cover glass on an upright type microscope.
- ◆ We recommend that you take a note of the reading of a well-visible position on the correction ring. Your note should help when you later use containers having different bottom plate thicknesses.
- ◆ The glass stage ring (option) is available to improve working efficiency, since it enables the part of operation to be seen from above the stage.

3) Cover glass thickness

Each objective has an impressed mark of specified cover glass thickness. (A mark "160/0.17" means an eyepiece tube length of 160mm and a specified cover glass thickness of 0.17mm.)

For an objective with a 0.17 mark, place a specimen so that its cover glass (0.17mm thick) faces the objective. (For an inverted microscope, set a specimen so that its cover glass faces down.) For an objective with a 1.2 mark, place a specimen so that its slide glass faces the objective, because the normal slide glass thickness is 1.2mm. (For an inverted microscope, set a specimen so that its cover glass faces up.)

When you observe a specimen in a laboratory dish or the like at high magnification through a glass not conforming to the specified thickness, we recommend use of an objective that has a correction ring capable of correcting the glass thickness error.

4) Oil immersion objective

The objective marked with "Oil" is an oil immersion objective.

Before using the oil immersion objective, be sure to immerse the space between the end of the objective and the specimen, in the optional oil (Nikon immersion oil). When you carry out fluorescent microscopy using the oil immersion objective for fluorescent microscopy, use the non-fluorescent oil (option). Use care to keep out air bubbles from the oil, since they will deteriorate visibility of images. Air bubbles may be found by observing the exit pupil (bright circle) of the objective. (If the eyepiece tube BT1 is used, the exit pupil of the objective can be observed by setting the turret assembly to B, bringing the Bertrand lens into the optical path, and adjusting the focus with the Bertrand lens focusing screw. If the eyepiece tube BT2 is used, the exit pupil can be observed by removing the eyepiece, inserting the centering telescope, and rotating the eyepiece into focus with the knurled ring held fixed.)

To remove air bubbles, rotate the revolving nosepiece slightly, and move the oil-immersed objective back and forth once or twice. Or, wipe the oil off, then reapply oil to the objective.

If excessive oil is applied, surplus oil flows out and adheres to the stage or other component. Use a minimum necessary amount of oil (enough to fill the space between the end of the objective and the specimen). Use care not to put oil to any other components.

If oil remains on the oil immersion objective or adheres to the surface of a dry objective, it will greatly reduce image visibility. After use, thoroughly wipe the oil off the objective surface. Also make sure that no oil has spread to the surfaces of other objectives.

To remove oil, moisten a lens tissue or clean cloth with xylene and lightly wipe the lens surface a few times. For better results, use a fresh part of a lens tissue.

9. Turret Assembly (For Eyepiece Tube BT1 only)

The turret assembly has four positions, O, B, C and M. Use them selectively. Use position O for normal microscopy.

- O: The optical path is becomes hollow.
- B: The Bertrand lens enters the optical path, enabling you to observe the exit pupil of the objective. Thus, this position allows centering of the phase contrast annular diaphragm and aperture adjustment of the condenser aperture diaphragm. Use the Bertrand lens focusing screw for focusing.
- C: The light blocking plate enters the optical path, shielding the external light from the eyepiece. This position is used for photomicrography.
- M: The magnifier lens enters the optical path, applying the $2.5\times$ intermediate magnification to the observation system. This position is used for observation at slightly higher magnification, or for focusing in photomicrography using the $4\times\sim 20\times$ objective.

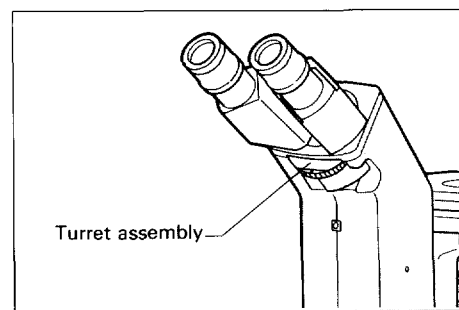

Figure 4-8

10. Diopter Adjustment

Turn down the reticle in/out lever on the front panel of the microscope to the right to put the photomask into the optical path.

While looking through the right-hand eyepiece with the right eye, rotate the diopter adjustment ring on the eyepiece to bring the double crosshairs of the photomask into sharp focus.

Then, look through the left-hand eyepiece with the left eye and carry on the same adjustment.

These adjustments correct dioptric difference of the right and left eyes, facilitating observation with both eyes. Since the eyepiece tube is held at the proper length, the high-grade objectives can demonstrate full performance and defocusing when objectives are changed is reduced.

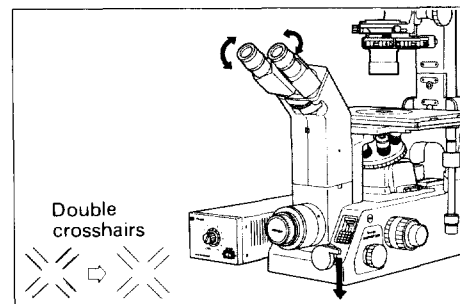

Figure 4-9

11. Adjusting Interpupillary Distance

Before adjusting the interpupillary distance, carry out steps 1. to 8. in Section II. "MICROSCOPY" to bring a specimen into focus using the 10 \times objective. Adjust the interpupillary distance until the viewfields overlap into one. Once the adjustment is complete, the microscope provides comfortable observation with both eyes.

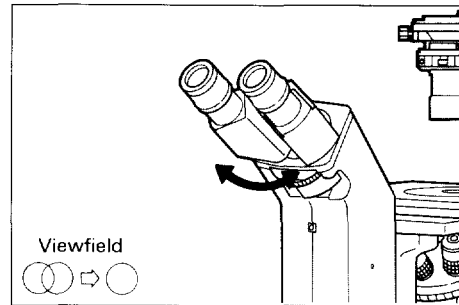

Figure 4-10

12. Photomask

The photomask of the pattern shown in the figure is put into the optical path by turning down the reticle in/out lever on the front panel of the microscope. This photomask is used for trimming and focusing in photomicrography, and diopter adjustment of the eyepieces.

Rectangular frame: The rectangular frame shows the photomicrography range of a 35mm SLR camera. It also shows the photomicrography range of a photomicrographic attachment used with the $2.5\times$ PL lens. (If a PL lens of different magnification is used, determine the photomicrography range by looking through the finder of the photomicrographic attachment.)

Double crosshairs: The double crosshairs are used for diopter adjustment of the eyepieces and centering of the condensers.

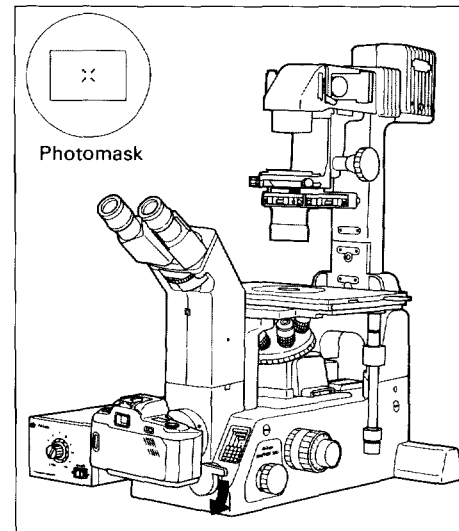

Figure 4-11

13. Eyepiece Tube

1) Height adjustment (For BT1 eyepiece tube only.)

NOTE

When adjusting the height of the eyepieces, be sure to hold the eyepiece tube by hand. The eyepiece tube gets damaged if it is dropped.

The eyepieces may be adjusted in five heights. (Adjustable range: 30mm above the reference position)

Loose the clamp screw on the right side of the eyepiece tube, then extend the eyepieces to a desired height.

If the eyepieces are drawn too high, hold the eyepiece tube by hand, and lightly press with a hexagonal screwdriver, the height pin which is located inside the hole of the front of the tube. By doing this, lower the eyepiece tube.

Be sure to hold the eyepiece tube by hand, since otherwise the eyepiece tube may drop and get damaged.

After the adjustment is complete, tighten the clamp screw.

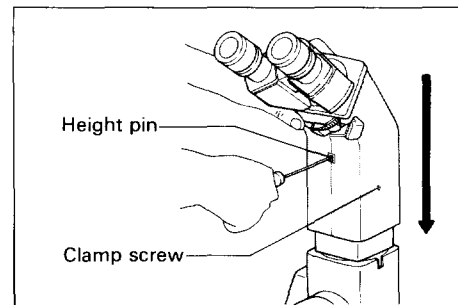

Figure 4-12

2) Removing and turning the eyepiece tube

The mounting direction of the eyepiece tube may be changed by loosening the eyepiece tube clamp screw with a hexagonal screwdriver. The eyepiece tube may be fixed at a 90-degree position to use the microscope in horizontal position.

If the eyepiece tube is removed and instead the optional eyepiece tube bracket is mounted, the eyepiece tube for an upright type microscope or other devices may be mounted. (For example, the teaching head or drawing tube)

14. Focusing Device

The arrows in the figure below show the directions in which you rotate the coaxial coarse/fine focusing knob to move the objectives.

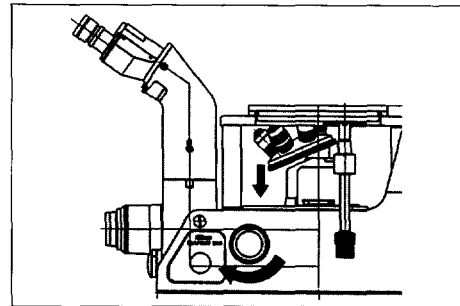

Figure 4-13

The following shows the relationship between rotation of the knobs and movement of objective:

- One scale division on the fine focusing knob gives $1\ \mu\text{m}$ of objective movement.
- One rotation of the fine focusing knob gives 0.1 mm of objective movement.
- One rotation of the coarse focusing knob gives 4 mm of objective movement.

The coarse/fine focusing knobs provide a 7-mm upward stroke and 3-mm downward stroke from the reference position.

Counterclockwise rotation of the torque adjustment ring on the right handle increases rotary resistance of the coarse focusing knob.

NOTE

- Never turn the right and left knobs of the microscope base in the opposite directions at the same time. Failure may result.
- Once the coarse focusing knob has reached its limit, do not force the knob beyond the limit. Failure may result.

15. Refocusing Stopper

The refocusing stopper on the left-hand coaxial coarse/fine focusing knob is used to mark the position of the coarse focusing knob where a specimen is in focus.

Once the refocusing stopper is clamped at the in-focus position, refocusing is much easier after the objective is shifted for specimen change or other purpose. All you have to do for refocusing is rotate the coarse focusing knob until it reaches the limit. The refocusing stopper is useful, for example, if the objective is very close to the stage because the container of the specimen has a thick bottom plate, and the magnification can only be changed by lowering the objective.

- (1) At the position where a specimen is in focus, turn the refocusing stopper clamp ring to clamp the stopper. The stopper has been clamped when the black triangle mark on the side of the clamp ring is at the upmost position.
- (2) Lower the focusing mechanism by using the coarse focusing knob only, then change the objective.
- (3) Raise the focusing mechanism slowly, again by using the coarse focusing knob only, until it reaches the limit. Here, the microscope is roughly in focus. Then, rotate the fine focusing knob to give a sharp focus.

When the refocusing stopper is not used, be sure to loosen the clamp until it reaches the limit. If clamped, the focusing mechanism cannot be moved up from the clamped position with the coarse focusing knob. However, stage movement with the fine focusing knob is not affected.

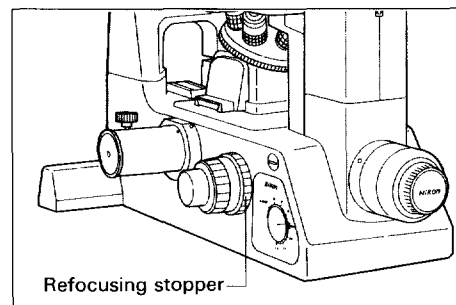

Figure 4-14

16. Handling Condenser Holder

1) Condenser refocusing stopper (Applicable to the LWD condenser only.)

The condenser refocusing stopper is used to mark the position of the condenser where the image of the field aperture diaphragm is in focus on the specimen surface. This stopper works in the range 13mm above and 3mm below the stage top surface.

The condenser refocusing stopper is very useful since it allows the condenser to be easily returned to the previous position even if it has moved up for specimen replacement. Use this stopper when the incubator (option) is used or when the pillar cannot be tilted.

Usage: Clamp the condenser refocusing stopper at the position where the image of the field aperture diaphragm is focused on the specimen surface.

Then, if the condenser is moved up temporarily for specimen replacement, just lower it to the limit. The condenser is back at the focus position where it was.

2) Rotating the condenser mount

The condenser mount can be rotated by loosening the rotation clamp screw. Rotate the condenser mount for differential interference microscopy or when adjusting the turret orientation.

If the system condenser turret unit is used, and the condenser holder is not fitted with a polarizer (in bright-field or phase contrast microscopy), the turret may be turned to the right or left and fixed using this function. The free space created this way may be available for mounting a manipulator, etc. (See page 44.)

3) Removing the condenser holder

The condenser holder may be removed from the diascope illumination unit. (See page 45.)

Remove the condenser holder to observe a specimen in a large container or when using the SLWD condenser.

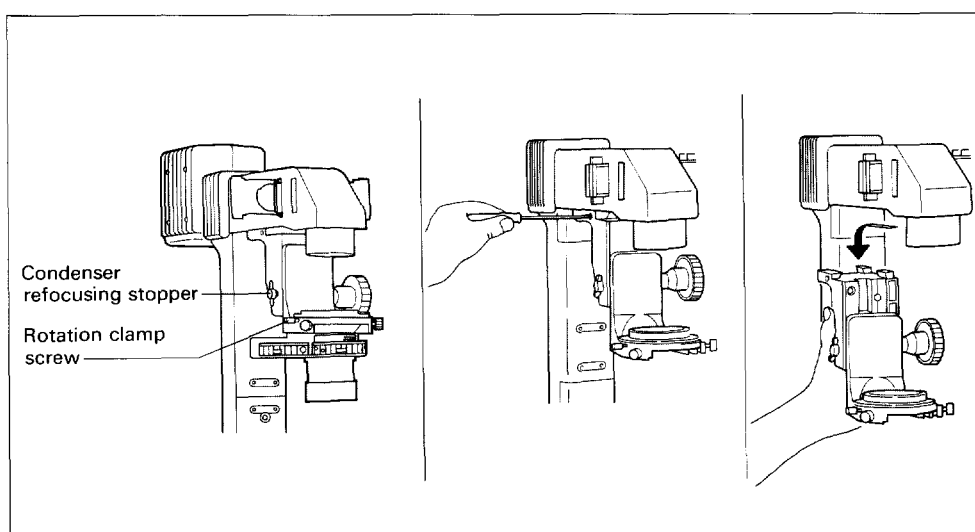

Figure 4-15

17. Tiltable Illumination Pillar

1) Tilting the pillar

The illumination pillar may be tilted to provide a wider operation space, which is useful to change large-size specimens.

As shown in the figure below, rotate and unlock the clamp screw on the rear of the pillar, hold the front of the diascope illumination unit (shown by arrow in the figure), and gently tilt the pillar toward the back.

Usually, the tilting clamp screw may be left unlocked.

But when relatively heavy attachments is attached to the pillar, the tilting clamp screw should be locked to avoid the pillar from accidentally tilting.

NOTE

- –CAUTION– Be careful not to get your fingers caught by the openings on the pillar when tilting it.
- Be sure to clamp the screws tightly when attaching the relatively heavy attachments such as optional high intensity light source. If not, they may drop when the pillar is tilted.
- When using the optional high intensity light source, be sure to check if they are clamped tightly before tilting the pillar. (To avoid the drop.)

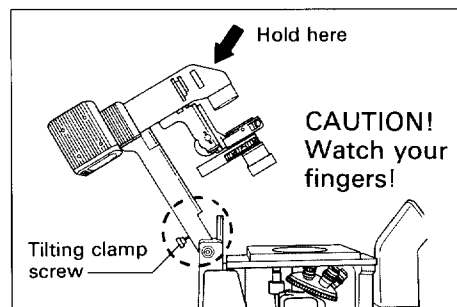

Figure 4-16

2) Screw holes for mounting various devices

The front surface of the pillar has eight M4 tapped holes for mounting a manipulator or other devices. The upper four holes are used to mount a device, which should be removed from above the stage when tilting the pillar. The lower four holes are used to mount a device, which should remain above the stage when tilting the pillar.

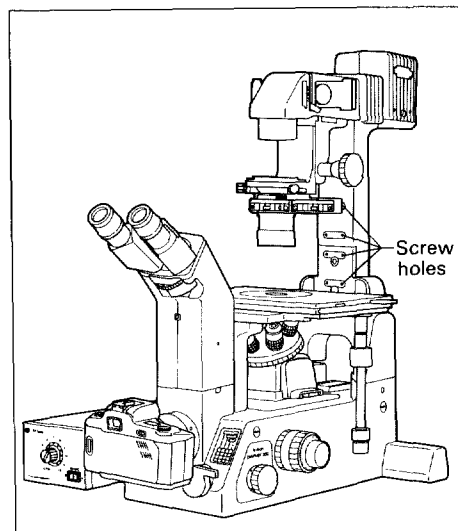

Figure 4-17

18. Rectangular Mechanical Stage

This stage has a handle with a universal joint, which enables the handle angle to be changed for smooth movement of the hand between the coaxial coarse/fine focusing knob and the handle on this stage.

Normally, this stage is installed so that its handle is at the rear right. (page 42)

The stage may also be installed in the diagonally opposite position, with the handle at the front left.

The stage has tapped holes in the top and bottom plates for mounting a manipulator or other experimental devices. The tapped holes in the bottom plate are used to mount a heat incubator. For the positions of these holes, see the figure below.

Two types of stage rings are available: 20mm dia. and 40mm dia. Use them selectively according to the sizes of specimen containers.

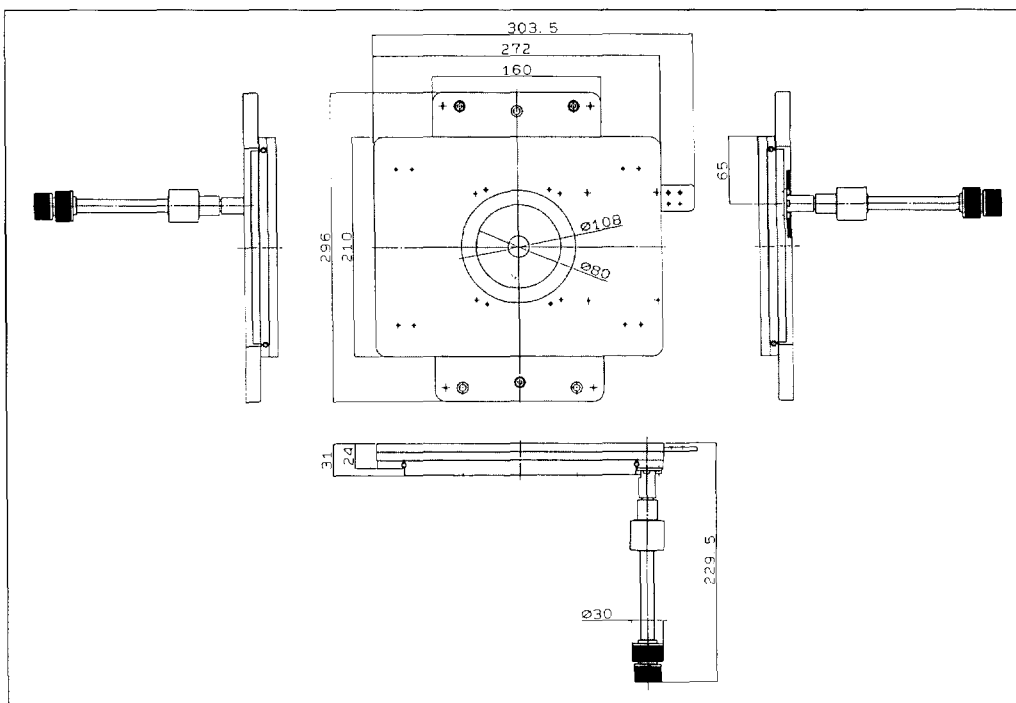

Figure 4-18

19. Photomicrography

1) Checking before photomicrography

Before starting photomicrography, ensure the following:

- (1) Eliminate illumination unevenness.

Make sure that:

- The condenser is centered. (See page 7.)
- The condenser annular diaphragm is centered (for phase contrast microscopy). (See page 9.)
- The aperture of the condenser aperture diaphragm is proper. (Normally 70 to 80% of objective's N.A.). (See page 22.)
- The field aperture diaphragm is stopped down to a range slightly larger than the photomicrography frame. (See page 21.)

- (2) Set the voltage and filter properly. (See page 17.)

	Lamp voltage	Filter
Daylight type color film	PHOTO	Put NCB11 into optical path.
Tungsten type color film	8	Remove NCB11.
Monochrome film	6 or more	Remove NCB11.

Use color correction (CC) filters obtainable on the market if necessary.

- (3) Focus the microscope properly. (See page 40.)

- (4) Prevent external light from entering. (See page 14.)

2) Relationship between photomask and photography range

- (1) 35mm SLR camera (on front port)

The rectangular frame of the photomask shows the range of photography.

The magnification on the film surface is the objective's magnification multiplied by 2.5 (the intermediate magnification of the microscope). If higher magnification is needed, use the conversion lens CL2 (option). Note that a magnification obtained by using an objective only is better in resolution than the same magnification obtained by combining a conversion lens with an objective.

- (2) Photomicrographic attachment

The rectangular frame of the photomask shows the photomicrography range of a photomicrographic attachment used with the 2.5× PL lens. If a PL lens of different magnification is used or the photomicrography range should be determined accurately, determine the photomicrography range by looking through the finder of the photomicrographic attachment. (Refer to the instruction manual of the photomicrographic attachment.)

3) Focusing in photomicrography

Focusing for photomicrography is carried out through the eyepieces with the photomask built in the microscope. This applies regardless of whether the photomicrography uses a 35mm SLR camera or a photomicrographic attachment.

- (1) Turn the reticle in/out lever to the right to bring the photomask into the optical path.
- (2) Set the turret assembly to O (eyepiece tube BT1 only). Rotate the diopter adjustment rings of the right and left eyepieces to focus on the double crosshairs in the photomask. (See page 29.)
- (3) Use the optical path changeover dial to direct the optical path to the port on which the camera is mounted.
Front port: B
Side port: C or D
- (4) Use the coaxial coarse/fine focusing knob to bring the specimen into focus.
 - High-powered objectives (40× or more)
Rotate the fine focusing knob slowly until both the double crosshairs and specimen image are clearly seen.
 - Low-powered objectives (4× ~ 20×)
Eyepiece tube BT1:
Use the coarse focusing knob to obtain focus. Set the turret assembly to M (to bring the magnifier (2.5×) into the optical path) to multiply the microscopy magnification by the intermediate magnification. (The use of the magnifier has no influences upon the photomicrography optical path.)
Rotate the fine focusing knob until both the double crosshairs and specimen image are clearly seen.
NOTE: Once the magnifier is brought into the optical path, do not carry out diopter adjustment on the eyepieces.
Eyepiece tube BT2:
Use the finder of the photomicrographic attachment, as the eyepieces are incapable of focusing at low magnification.
Mount the focusing telescope on the finder, and looking through it, move the focusing telescope back and forth until the double crosshairs are clearly seen. Then, rotate the fine focusing knob to bring the double crosshairs and specimen image into sharp focus.
- (5) If a objective with a correction ring is used, make sure that the correction ring is properly adjusted. (See page 26.)

4) Precautions on photomicrography

- (1) 35mm SLR camera
 - Adjust the brightness with the ND filter so that the exposure time (shutter speed) is longer (slower) than 1/8 second. For monochrome photomicrography, the brightness may be adjusted by varying the lamp voltage.

- To prevent external light from entering, be sure to keep the finder cap (option) on the viewfinder eyepiece of the camera. The finder may only be removed if your camera displays exposure time in the viewfinder and you want to check exposure time.
- If the shutter is to be pressed with your eye kept away from the microscope eyepiece, as in the case of long-time exposure, set the turret assembly to C to prevent external light from entering through the eyepiece. (This applies to the eyepiece tube BT1 only.)
- Even if all microscope components are adjusted properly, the view field looked through the camera's eyepiece is eclipsed. This has no influences upon photomicrography, however.
- If no cable release is available, we recommend that the self-timer of the camera be used to avoid vibration of pressing the shutter button.

(2) Photomicrographic attachment

- If the shutter is to be pressed with your eye kept away from the microscope eyepiece, as in the case of long-time exposure, set the turret assembly to C to prevent external light from entering through the eyepiece. (This applies to the eyepiece tube BT1 only.)
- For details of photomicrographic operations, refer to the instruction manual of the photomicrographic attachment.
- If a photomicrographic attachment with a Polaroid or 35mm dark box is mounted on the side port, its cover will not open fully. Do not attempt to force the cover full open.

5) When using Nikon F-601



Use Nikon F-601 with the following settings. Please refer to the instruction manual supplied with the camera for the details.

(1) Standard setting

Film speed	DX-coded films: DX (automatic film speed setting) non-DX-coded films: M (manual speed setting)
Film advance mode	S (single-frame shooting)
Focusing	M (manual focus)
Exposure metering system	 (matrix metering)
Exposure mode	A (aperture-priority auto)

(2) To get proper exposure on a certain object

Change as follows.

Exposure metering system	 (center-weighted metering) or  (spot metering)
--------------------------	--

Refer to the instruction manual of the F-601 for the area to be metered.

(3) To make long exposure

Change as follows.



Exposure mode	M (manual) set shutter speed to "bulb"
---------------	---

(4) Self-timer operation

While pressing  button, rotate command dial until desired timer duration appears on the LCD panel.

V . ASSEMBLY

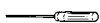
Tools required:

Supplied hexagonal screwdriver × 2 
and hexagonal wrench × 1 

1. Installing the base

Take the base out of the package, and place it on a stable surface. Be sure to firmly hold the portions shown in the figure below because the base is heavy.

- Leave a space of approx. 20cm between the base and the nearby wall to allow the user to look at the warning labels on the lamphouse.
- This microscope has a tiltable illumination pillar, which may be tilted backward for changing large-sized specimens. It is recommended that a space of approx. 40cm be left behind the microscope.

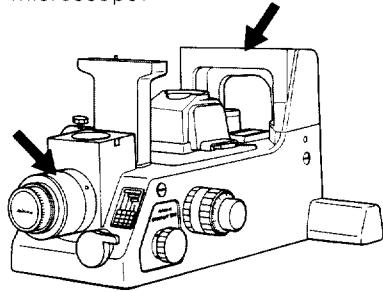

2. Mounting the revolving nosepiece

Install the revolving nosepiece to the circular dovetail mount at the focusing mechanism on the base center. More specifically:

Loosen the revolving nosepiece clamp screw (hexagonal socket head screw) with the hexagonal screwdriver, fit in the revolving nosepiece so that its groove fits on the pin of the dovetail mount. Then tighten the clamp screw to secure the nosepiece.

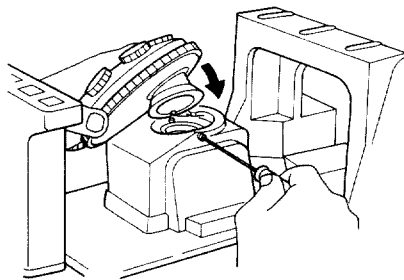

3. Installing the stage

Place the stage onto the pedestal on the base so that the handle is located at the rear right or front left. Secure the stage by tightening the three stage clamp screws (M5 hexagonal socket head screws) with the hexagonal wrench.

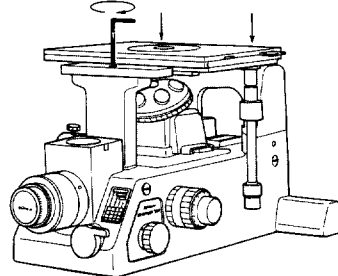

4) Installing the illumination pillar

Mount the illumination pillar on the pedestal at the back of the base. Then secure the pillar by tightening the three illumination pillar fixing screws (M5) with the hexagonal wrench.

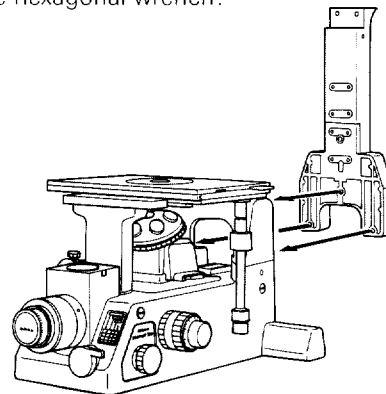

5. Installing the diascope illumination unit

Place the diascope illumination unit on top of the illumination pillar. Secure the unit by tightening its two screws (M5) with the hexagonal wrench.

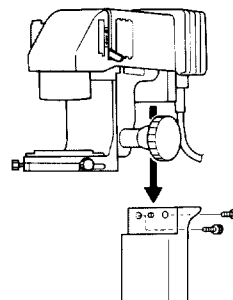

6. Setting the 33mm filter

(GIF, NCB11, ND2, ND16 and heat insulation filter)

Remove the filter slider from the diascopic illumination unit. As shown in the figure below, push aside the claw and set the 33mm filter in the filter slider.

When setting or removing the filter from the filter slider, wear gloves or use gauze to avoid direct touch by your fingers.

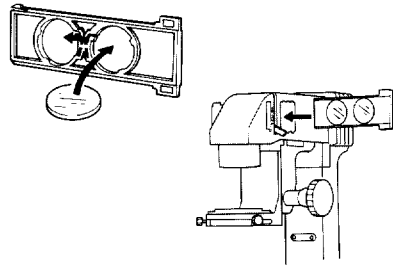

7. Mounting the eyepiece tube

Loosen the eyepiece tube clamp screw of the eyepiece port (dovetail mount) at the front of the base, using the hexagonal screwdriver. Tilt the eyepiece tube slightly and attach it to the dovetail mount, and tighten the clamp screw to secure the eyepiece tube.

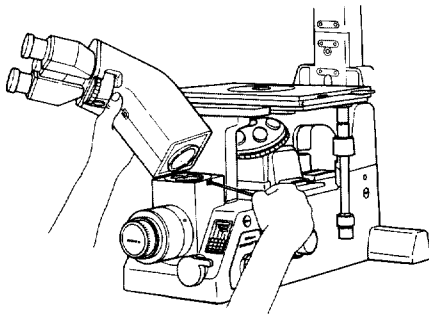

8. Mounting the eyepieces

The right and left eyepieces must be of the same magnification.

Remove the dust caps from the eyepiece sleeves. Insert the eyepieces into the eyepiece sleeves by fitting their three grooves with the three projections on each sleeve.

If the rubber eye guards (option) are to be used, fit them over the eyepieces.

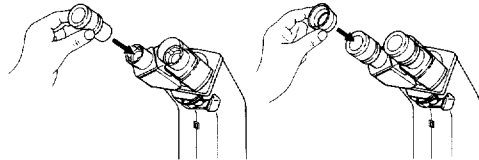

● Rotation clamp ring for the eyepiece

The rotation clamp ring is mounted on the eyepiece sleeve to prevent the rotation of the eyepiece.

When removing the eyepiece, **take care not to accidentally hold this ring and pull it out together with the eyepiece.**

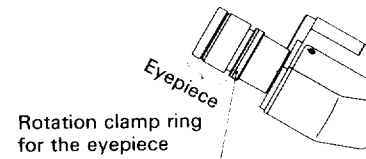

The rotation clamp ring must be removed when mounting the old type of eyepiece. When attaching the ring again, note on the following points.

Hold the so that **the $\phi 0.8$ protrusion on the brim faces up.** There are **two pawls on the ring** and **two grooves on the sleeve** to prevent the ring from falling off. **Attach the ring so that these pawls and grooves fits together.**

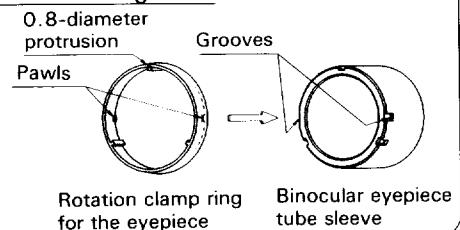

9. Mounting the condenser

● Mounting the system condenser turret unit

First you assemble the system condenser turret unit, as follows:

● ELWD condenser

Leave the hollow module (with mark "A") in the turret as is. Set the modules PhL to Ph3 (annular diaphragm modules marked in red), into the remaining module ports so that when looked from above, their numbers increase with clockwise rotation of the turret. Fix each module with two hexagonal socket head screws. Screw the ELWD condenser lens (marked in red) into the turret unit.

● LWD condenser

Set the supplementary lens into the pocket of the diascopic illumination unit. (page 24)

Remove the hollow module (with mark "A") from the turret by loosening the two hexagonal socket head screws. (The removed module A is used for bright-field microscopy.)

Set the modules PhL to Ph4 (annular diaphragm modules marked in black), into the module ports so that their numbers increase with clockwise rotation of the turret. Fix each module with two hexagonal socket head screws.

Screw the LWD condenser lens (marked in white) into the turret unit.

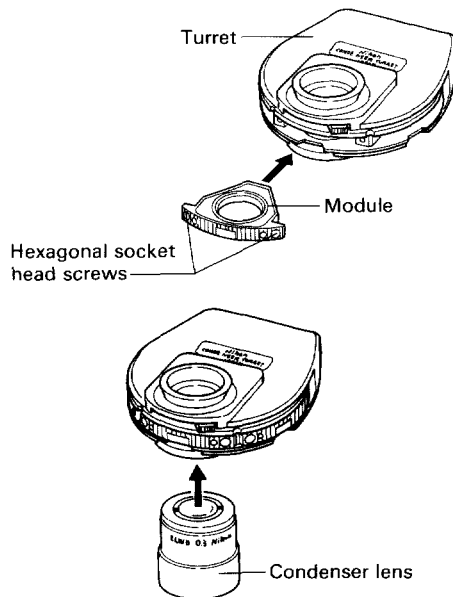

Now you install the system condenser turret unit to the microscope, as follows:

Using the hexagonal screwdriver, loosen the condenser clamp screw (hexagonal socket head screw) located deep in the right-hand hole of the condenser holder. (If the clamp screw is hidden and the screwdriver cannot be inserted, loosen the mount rotation clamp screw on the left of the condenser holder, rotate the mount center by hand until the pin at the top of the mount aligns with the groove in the mount center, and tighten the mount rotation clamp screw to secure.)

Mount the system condenser turret unit so that the mark on the module on the optical path face the front side, and tighten the clamp screw with the hexagonal screwdriver to secure the turret unit.

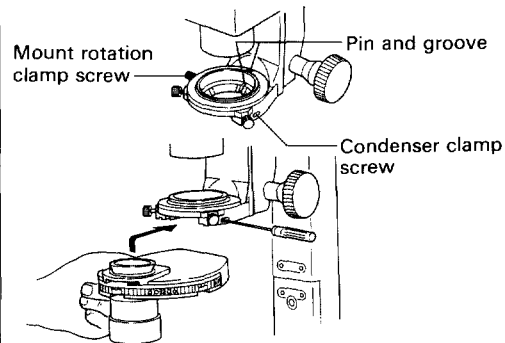

● Mounting the ELWD condenser

Mounting procedures are the same as above system condenser turret unit.

Using the hexagonal screwdriver, loosen the condenser clamp screw (hexagonal socket head screw) located deep in the right-hand hole of the condenser holder. (If the clamp screw is hidden and the screwdriver cannot be inserted, loosen the mount rotation clamp screw on the left of the condenser holder, rotate the mount center by hand until the pin at the top of the mount aligns with the groove in the mount center, and tighten the mount rotation clamp screw to secure. See above figure.)

Mount the condenser so that the marks on the turret face to the front side, and tighten the clamp screw with the hexagonal screwdriver to secure the condenser. (See above figure.)

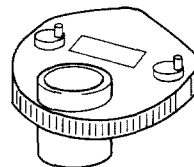

● Mounting the SLWD condenser

Remove the condenser holder from the illumination pillar. (Lower the condenser holder till the limit by the condenser focusing knob. Loosen the condenser holder clamp screw by the hexagonal screw driver, and slide the holder back to detach the holder.)

Install the condenser lens to the field lens screw mount on the illumination pillar. Remove the dust-proof slider or supplementary lens from the supplementary lens pocket and insert the SLWD condenser slider instead.

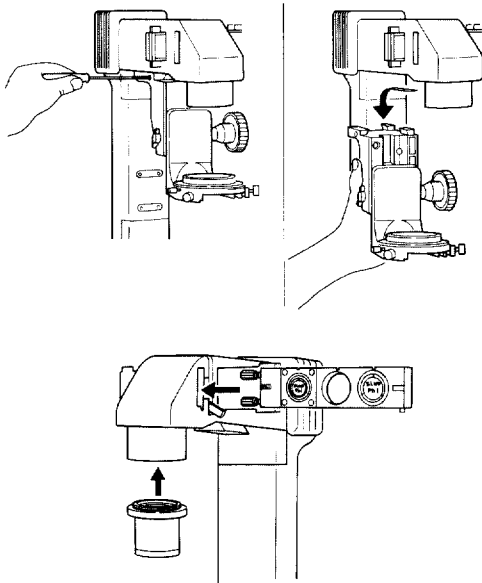

10. Installing objectives

Remove the stage ring from the stage. Install objectives in such places that magnification increases with clockwise rotation of the revolving nosepiece. Refit the removed stage ring. (See the figure below.)

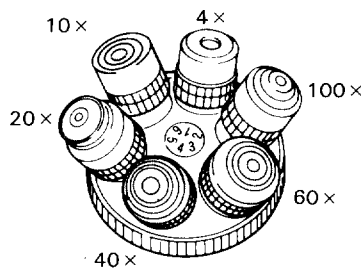

11. Installing the lamp and lamphouse

NOTE: ● Use the specified Lamp House Unit, Nikon, Halogen 12V100W.

- Be sure to turn OFF the power switch and plug out the power cord before installation.
- Do not touch the lamp bulb with bare hands. Keep it in the cover or wear gloves. If dirt or fingerprints are put on the bulb, thoroughly wipe them off. Be sure to remove the lamp cover after the lamp bulb is mounted.

- (1) Loosen the lamphouse cover clamp screw with a coin or the like;
- (2) Remove the cover;
- (3) Press down the lamp clamp lever, and while doing this;
- (4) Insert the lamp into the socket pin hole as far as it touches the stopper;
- (5) Set the lamp clamp lever to the previous position. Be careful so the lamp is mounted upright. If it is tilted, retry;
- (6) Close the cover; and
- (7) Tighten the lamphouse cover clamp screw.

Align the anti-rotation pin on the lamphouse mount to the groove in the cylindrical part of the lamphouse, insert the lamphouse into the lamphouse mount, then secure the lamphouse by tightening its clamp screw.

● Removing the lamphouse

CAUTION: Lamp House is very hot immediately after lamp is turned off. Make sure that it is sufficiently cool before replacement.

For safety, tighten the tilting clamp screw of the illumination pillar.

Set the power switch off (or make sure that it is set off).

Loosen the lamphouse clamp screw, then draw the lamphouse out of the base.

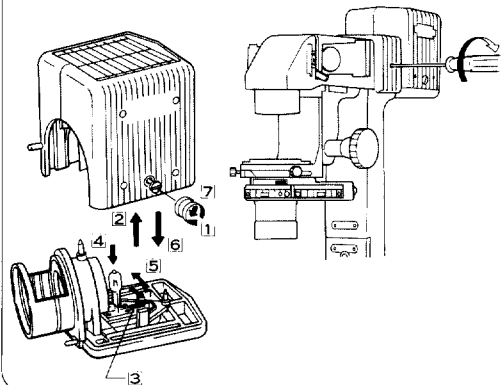

12. Connecting the power supply

Plug the lamp cable connector into the socket on the power supply unit. Secure the connector by rotating the lock ring as far as it goes.

Connect the power cable to the power connector on the power supply unit.

13. Connecting the ex-control cable

(The ex-control cable is used only when controlling light intensity via the light intensity control dial on the microscope body.)

Plug the ex-control cable connector into the socket on the rear panel of the microscope.

Plug the other connector of the ex-control cable to the CTRL connector socket on the rear panel of the power supply unit.

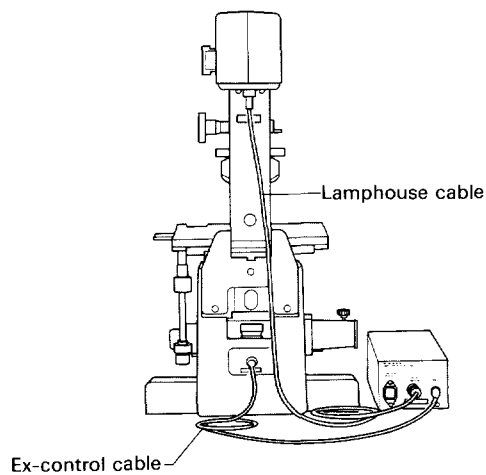

14. Installing a 35mm SLR camera

Remove the F mount cap from the front port.

Align the lens in/out index on the camera to that on the front port, mount the camera, then rotate the camera in the direction of the arrow until it stops with a click. (See the figure below.)

Install the cable release (option) by screwing the thread at its end over the cable release screw of the camera.

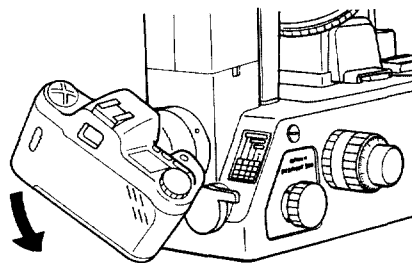

To dismount the camera, press the lens dismantling button on the camera, and hold the button depressed while rotating the camera in the opposite direction of the arrow until it stops. Then, gently dismount the camera. Note that the F mount may be damaged if you attempt to rotate the camera in the direction of the arrow.

For film loading, photomicrographic mode selection, etc., refer to the instruction manual of the 35mm SLR camera.

15. Installing the photomicrographic attachment MICROFLEX Series (option)

Refer to the instruction manual of the photomicrographic attachment for detailed information about its assembly, film loading, photomicrographic mode selection, and photomicrographic procedures.

- To install the photomicrographic attachment on the side port:
Assemble the photomicrographic attachment with reference to its instruction manual.
Remove the cap from the side port. Insert the PL projection lens into the side port until its thrusting surface contacts the sleeve. Install the photomicrographic attachment to the side port sleeve so that its finder faces the front. Insert the connection ring into the sleeve until the abutting point firmly seats, then fix the ring securely with the clamp screw.
In photomicrography, adjust the optical path changeover dial on the right of the base to D when focusing through the eyepieces. When taking a photograph, adjust the dial to C.

- To install the photomicrographic attachment on the eyepiece tube port:
Assemble the photomicrographic attachment with reference to its instruction manual.
Remove the eyepiece tube by loosening its clamp screw with the hexagonal screwdriver.
Install the optional eyepiece tube bracket by slightly tilting it toward the dovetail groove, and secure bracket with the clamp screw.
Install the eyepiece tube for upright type microscope (optional triocular eyepiece tube F or T) by fitting it over dovetail mount of the eyepiece tube bracket, then tighten the clamp screw.
Insert the PL projection lens into the vertical tube of the eyepiece tube until its thrusting end contacts the vertical tube.
Mount the photomicrographic attachment onto the vertical tube so that the finder faces the front.
In photomicrography, set the optical path changeover dial on the right of the base to A. Direct the optical path to the vertical tube by operating the optical path changeover lever on the eyepiece tube, etc.

Now the assembly is completed.

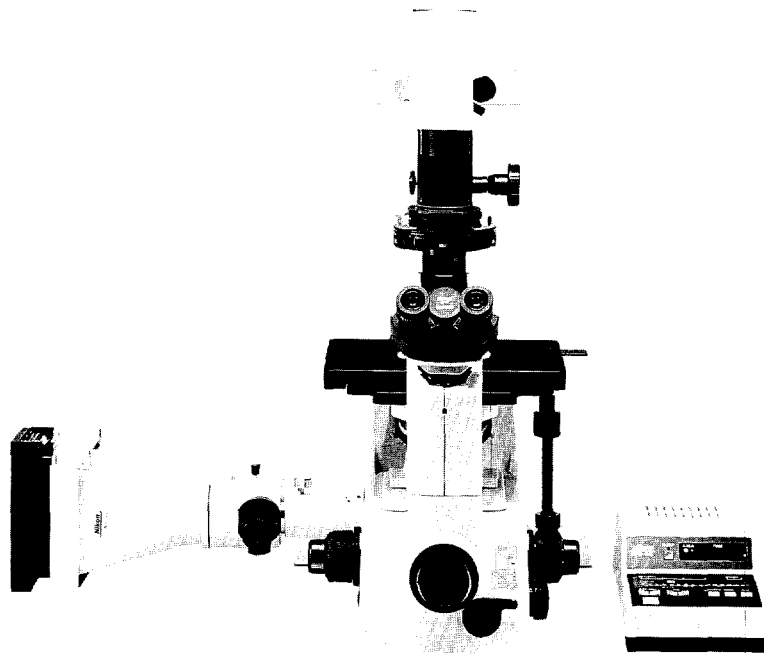

VI. SYSTEM DIAGRAM

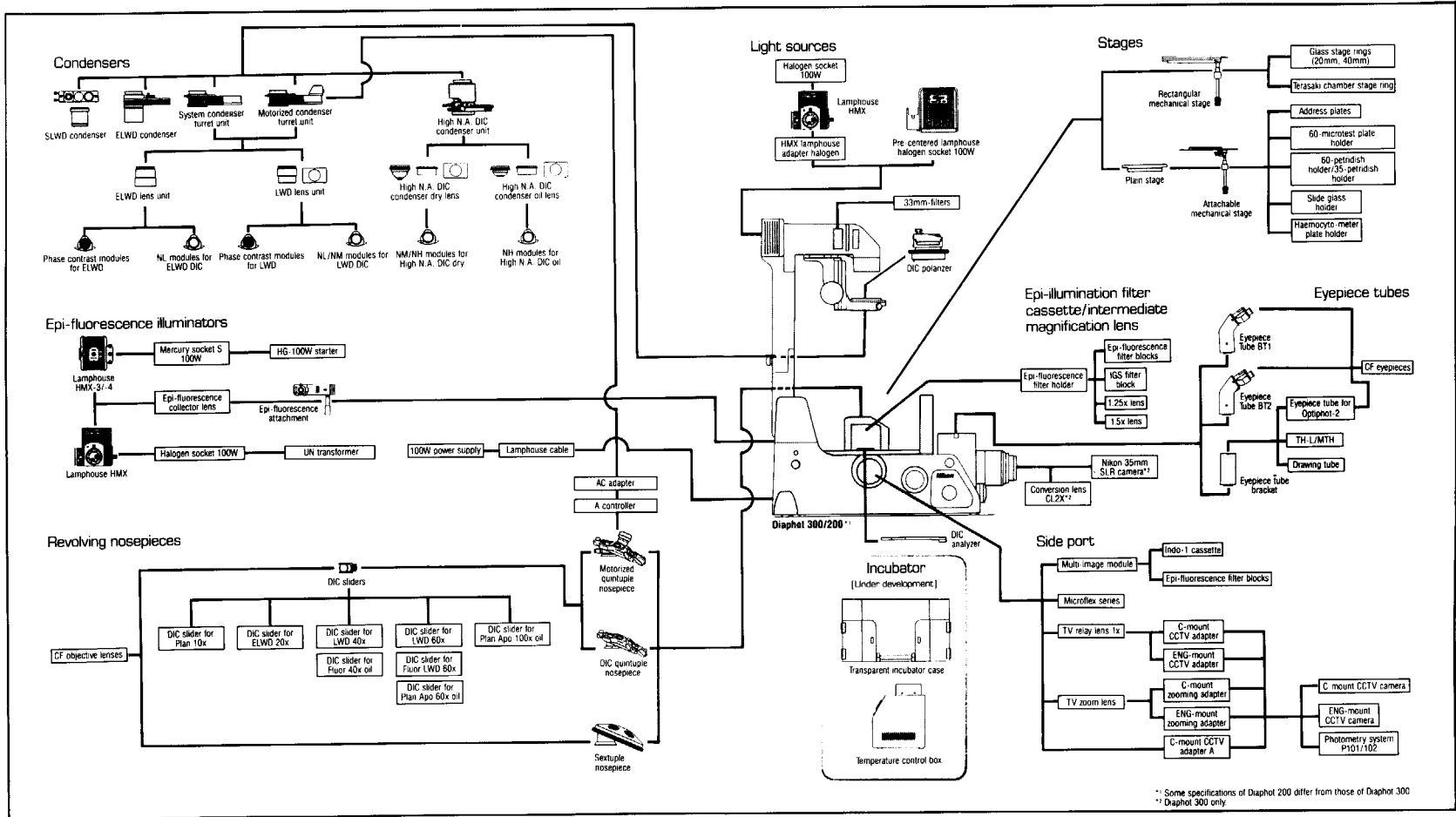

VII. TROUBLESHOOTING

If the microscope does not function properly, take appropriate action as described below.

1. Optical

Symptoms	Causes	Countermeasures
Viewfield vignetting, uneven brightness, or viewfield only partially visible	Optical path changeover dial not in clickstop position	Rotate to clickstop position.
	Revolving nosepiece not correctly mounted on focusing mechanism	Mount securely.
	Revolving nosepiece not in clickstop position (Objective not in optical path)	Set to clickstop position.
	Slider in focusing mechanism not in clickstop position	Set to clickstop position.
	Incorrect condenser mounting	Mount correctly.
	Incorrect condenser turret positioning	Correctly set to the position that matches the objective.
	Incorrect turret assembly positioning	Set turret to {0} position.
	Photomask in intermediate position	Turn reticle in/out lever until it clicks at stopper.
	Stage ring in optical path	Change specimen position and move stage.
	Field aperture diaphragm image not in focus on specimen surface	Rotate condenser focus knob to bring field aperture diaphragm image into focus on specimen surface. (For LWD condenser with supplementary lens, loosen refocusing stopper before this operation.)
	Field aperture diaphragm stopped down excessively	Open diaphragm properly.
Dirt or dust in viewfield	Dirt or dust on lens (field lens, condenser, eyepiece) or culture container	Clean lens or culture container.
	Field aperture diaphragm image not in focus on specimen surface	Rotate condenser focus knob to bring field aperture diaphragm image into focus on specimen surface. (For LWD condenser with supplementary lens, loosen refocusing stopper before this operation.)

Symptoms	Causes	Countermeasures
Poor image quality (No effect of phase contrast; or poor contrast or resolution)	Bright field objective is used	Use phase contrast objective.
	Condenser annular diaphragm not put in optical path	Select annular diaphragm (module) that matches Ph code of the objective. Put it into optical path.
	Phase rings different between condenser annular diaphragm and objective	Select annular diaphragm (module) that matches Ph code of the objective. Put it into optical path.
	Condenser annular diaphragm poorly centered	Center annular diaphragm.
	Dirt or dust on lens (field lens, condenser, eyepiece) or culture container	Clean lens or culture container.
	Objective's correction ring not set to glass (or plastic) thickness of culture container	Make correction.
	Culture container glass (or plastic) is thicker than 2mm	Use glass (or plastic) not thicker than 2mm.
	Field aperture diaphragm image not in focus on specimen surface	Rotate condenser focus knob to bring field aperture diaphragm image into focus on specimen surface.
Uneven focus	Nosepiece not in clickstop position	Rotate to clickstop position.
	Nosepiece incorrectly mounted	Mount properly.
Image shift while focusing	Specimen tilted on stage surface	Correctly reposition specimen on stage.
	Nosepiece not in clickstop position	Rotate to clickstop position.
	Nosepiece incorrectly mounted	Mount properly.
	Condenser annular diaphragm off-centered	Recenter condenser annular diaphragm.
	Condenser incorrectly mounted	Mount properly.
	Illumination pillar stopped halfway	Gently bring pillar into contact with stopper.
Yellowish image	No NCB11 filter in optical path	Insert NCB11 filter into optical path.
	Lamp voltage too low	Adjust light intensity control dial to 9 or PHOTO (for dial on microscope body) or higher.

Symptoms	Causes	Countermeasures
Viewfield too bright	No ND filter in optical path	Insert ND filter(s) into optical path.
	Too high voltage setting with light intensity control dial	Set to lower voltage with light intensity control dial.
Viewfield too dark	Condenser aperture diaphragm stopped down excessively	Open diaphragm properly.
	Field aperture diaphragm image not in focus on specimen surface	Rotate condenser focus knob to bring field aperture diaphragm image into focus on specimen surface.
	Optical path changeover dial set to B or D	Set optical path changeover dial to A.

2. Operational

Symptoms	Causes	Countermeasures
Focusing impossible with objective raised to highest position	Stage mounted incorrectly	Mount correctly.
Focusing impossible with 20× or 40× objective	Culture container glass (or plastic) thicker than 2mm	Use glass (or plastic) not thicker than of 2mm
Binocular images not coincident	Incorrect interpupillary adjustment	Adjust interpupillary distance.
Eye fatigue experienced during observation	Incorrect diopter adjustment	Correct diopter adjustment.
	Inadequate illumination brightness	Correct lamp voltage. Or, adjust with ND filter.

3. Electrical

Symptoms	Causes	Countermeasures
Pilot lamp does not light when main power switch is turned ON	Power cable connector almost unplugged	Connect power cable securely.
	Built-in fuse of power supply unit blown out	Contact your dealer.
Lamp does not light	Lamp burnt	Replace with specified lamp.
Lamp burnt too early	Non-conforming lamp	Replace with specified lamp.
Light intensity control impossible with dial	Lamp burnt	Replace with specified lamp.
	Non-conforming lamp	Replace with specified lamp.
	Cable connection improper	Connect cable securely.
Ex-control impossible	CTRL connector loose	Connect CTRL connector securely.
	Light intensity control dial on power supply unit not set to CTRL position	Set to CTRL position.

ELECTRICAL SPECIFICATIONS

■Diaphot 300

Input Ratings	12V DC, 100W
Halogen Lamp	Lamp rating: 12V, 100W Lamp type: OSRAM HLX64623 or PHILIPS 7724
Protection Class	Class III
Comforming Standards	This product conforms to DIN VDE 0411, IEC1010 and UL1262.

■PSM-1120 (Power Supply Unit for 100-120V Input voltage)

Input Ratings	100-120V~, 3A, 50/60Hz
Output Ratings	12V DC, 100W
Protection Class	Class I
Comforming Standards	This product conforms to UL1262.
Power Supply Cord Instruction	Use only the following cord set. UL Listed, detachable cord set. 3-conductor grounding type SVT, No. 18 AWG rated a minimum 125V, 7A.

■PSM-2120 (Power Supply Unit for 220-240V Input voltage)

Input Ratings	220-240V~, 2A, 50/60Hz
Output Ratings	12V DC, 100W
Protection Class	Class I
Comforming Standards	This product conforms to EN60950 and DIN VDE 0411.
Power Supply Cord Instruction	Use only approved 3-pole power supply cord type H05VV-F or H0VVH2-F, min. 0.75mm ² Class I equipment should be connected to PE (protective earth) terminal. In case of using the extention cord, use only the power supply cord included PE wire.

External View:

