

Thermo Scientific Hamilton SafeAire II Fume Hoods

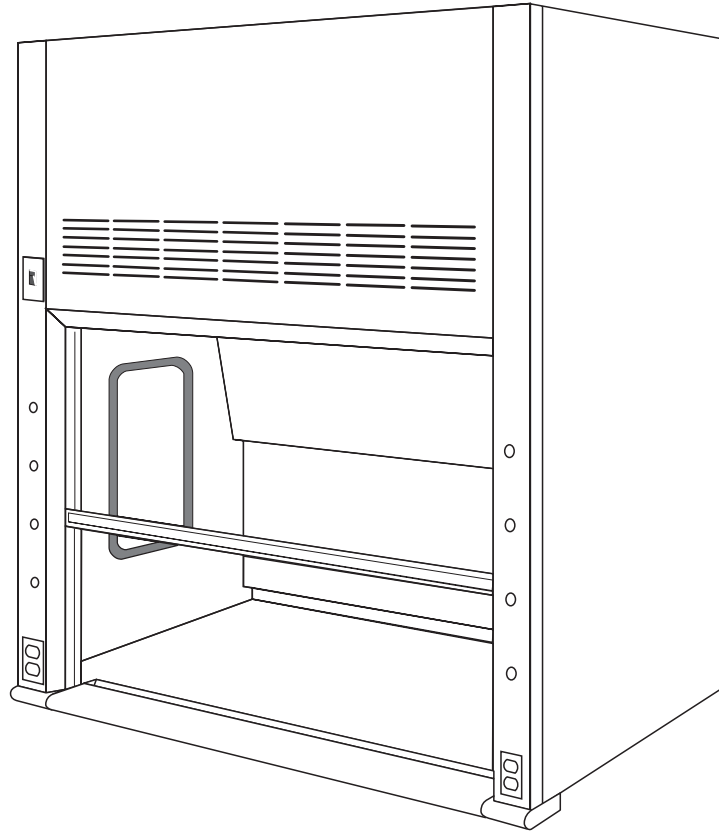

Operation, Maintenance and Installation Instructions

General Information	4-5
General	4
Perchloric Acid Fume Hoods	4
Fume Hood Identification	5
Installation	6-10
Fume Hood Superstructures	6
HOPEC IV Superstructures	7-8
Baffles	9-10
Blower Enclosures	11
Fume Hood Monitor	12
Exhaust Filter Assembly	12
Minihelic Gauge	12
Warning and Operating Instructions	13
Maintenance and Adjustments	14-19
General Maintenance	14
Fume Hood Inspection	14
Cleaning Fume Hood Interiors	14
How to Replace Fluorescent Light Tube	15
Servicing Fume Hood Fixtures	15
Installation of Access Panel	15
Access Through Front Posts	15
Replacing Sash Glass and Cables	16-18
Exhaust Filter Replacement	18
Blower RPM Adjustments	19
Manometer, Monitoring Exhaust Filters	19
Field Testing	20
Fume Hood Testing	21-22
Troubleshooting	23

Dimensions are nominal, and illustrations and specifications are based on the latest product information available at the time of publication. The right is reserved to make changes at any time without notice.

General

Fume hoods are exposed to temperature extremes, reagent fumes and work surface abuse. Regular care will prolong service life and ensure safe working conditions.

The exhaust system and fume hood blower must function properly for safety.

Air velocity checks can be made with a thermal anemometer. See Fume Hood Inspection Procedures, page 14 and Field Evaluation, page 22.

Always place equipment and apparatus as far back into the fume hood as possible to provide greater assurance of proper fume collection and removal.

Large, bulky apparatus or equipment should be positioned in the fume hood to permit air flow around it. Raise large items an inch or two above work surface. Spilled liquids, acids or corrosive materials should be cleaned immediately and the surface neutralized with water or a proper neutralizing agent to prevent damage to the fume hood interior, work surface and apparatus or equipment installed in the fume hood.

Special fume hoods are required for the handling of Perchloric Acid.

Perchloric Acid Fume Hoods

The properties of perchloric acid require that a specially designed fume hood be set aside for exclusive use with this material. The fume hood is equipped with a cold water spray device for washdown of the interior surfaces. A trough is placed across the back of the fume hood for collection and disposal of washdown waters. Operating personnel should be well trained in the proper handling techniques and be familiar with the characteristics of this material.

Frequency of washdown, both fume hood interior and exterior system, is determined by the usage and concentration of reagents. This can range from a weekly procedure to one that occurs after every use. Washdown should always be followed by an inspection to verify that all areas are clean and that the wash system is functioning properly.

Some of the hazards of perchloric acid which justify the use of a special fume hood are:

1. Perchloric acid is a very strong acid, capable of producing severe burns when in contact with skin, eyes or respiratory tract.
2. As an aqueous solution, it can cause violent explosions if improperly handled.
3. It reacts with other substances to form unstable materials which are susceptible to exploding either by impact, friction, or spontaneous combustion.

Persons using perchloric acid should be thoroughly familiar with its hazards. Many reported laboratory accidents have involved less than one gram of reactant. Listed below are some common safety practices that should be followed:

- Spilled perchloric acid should be thoroughly washed away with large amounts of water.
- The use of organic chemicals or materials in the fume hood should be avoided.
- Goggles or other effective eye protection should be used whenever possible, as well as utilization of the fume hood sash for additional safety.
- Gas flames or oil baths should not be used within the fume hood.
- Organic chemicals should not be kept in storage areas set aside for perchloric acid storage.
- A schedule should be made for regular washdown and inspection of fume hood interior, ductwork and blower to guard against a build-up of dangerous perchloric materials.
- Only fluorocarbon grease should be used as a blower lubricant as any other type is considered potentially hazardous.
- Washdown procedure should be performed after completion of usage with all apparatus removed from fume hood.

Fume Hood Identification

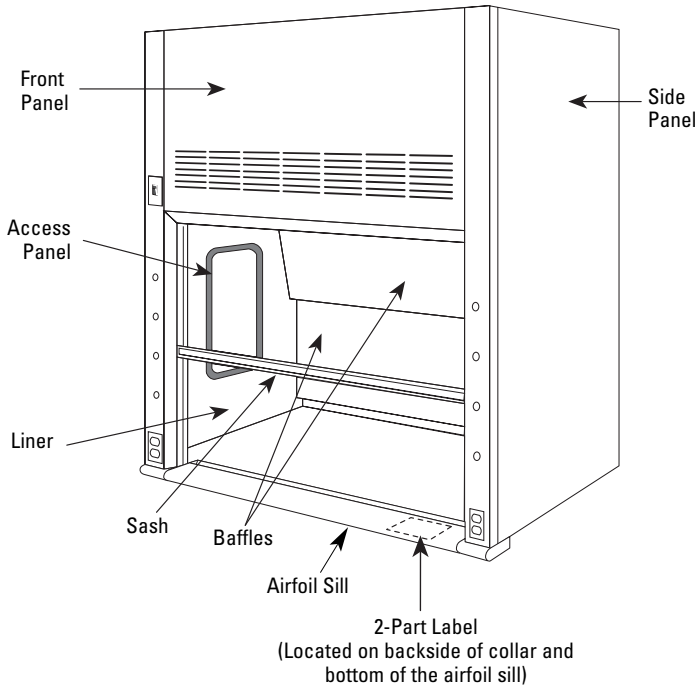

Fisher Hamilton L.L.C. Two Rivers, WI 54241		TX 394381 FH3943810244 X54L836PD - DWG. HD01
Item/Room No.	Item: 158C Room: 207	
Job/Unit No.	TX 394381 012 H012M Unit: 0005093	TX 394381 FH3943810244 X54L836PD - DWG. HD01
Product No.	FH3943810244 Entity:	
Description	Desc: X54L836PD - DWG. HD01	
Project Name	Project Name: RICE UNIVERSITY - OLD CHEMISTRY	
Shop Order No.	Shop Order #: 161914 P.O. No.: 22492/26108	
Bar Code No.	 018021957 Clr: G1 UNCRATED	

Placed on backside of collar

Placed on bottom of airfoil sill

Fume Hood Superstructure Installation

Side Enclosure Panels

1. Press down on two black catches and rotate side panel away from fume hood. Lift side panel off of lower lip frame.

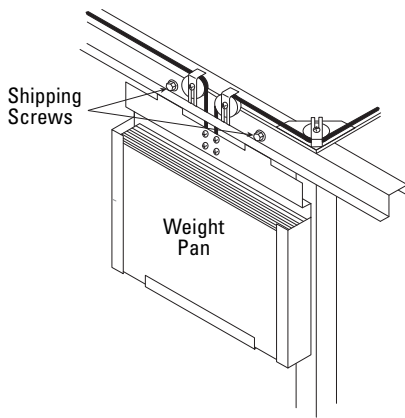
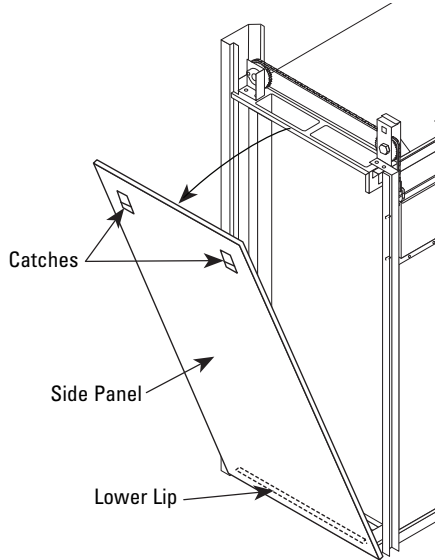

2. Remove two shipping screws that secure the counter-balance weight pan to the rear top rail.
3. Remove screws from sash hold-down clips. Open the sash and remove blocking, being careful not to damage sill or baffles.

Baffles can be installed at this time or after the fume hood is in place on the work surface. See Page 9.

4. Remove shipping screws holding the fume hood frame to the skid. Save four of these screws, No. 10 x 5/8", to secure fume hood to the work surface.
5. Place the fume hood on the work surface taking care to protect the work surface.

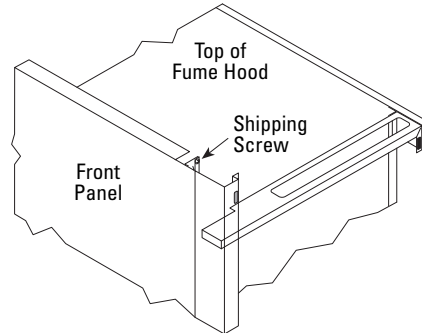

6. Remove two shipping screws from the top of the front panel. **These screws must be removed to allow future access to the fluorescent lights.**
7. Check the following items:
 - That the counterweight operates free of obstructions.
 - That the cables align properly in the pulleys.
 - That there is proper horizontal sash alignment and counterweight balance.
 - That the sash does not bind in the sash guides.

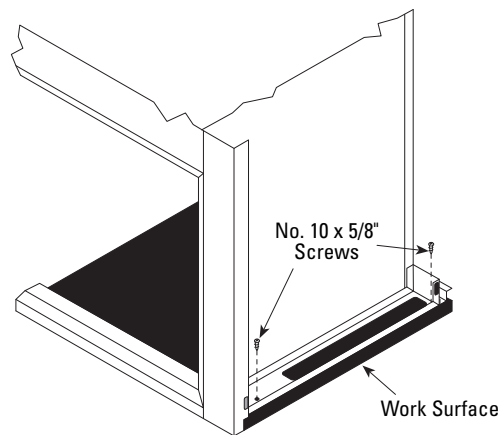

8. Drill two each 1/8" diameter pilot holes at each side structural frame into the work surface and secure same with four No. 10 x 5/8" screws saved from the shipping skid.
9. Reinstall end panels.
10. Caulk fume hood to work surface with silicone sealant.

HOPEC IV Fume Hood Installation

1. Install and level two fume hood base cabinets with rear fillers and kneespace panel as required.
2. Depending on height requirements, install either the top filler frame assembly alone or in combination with the optional-height filler frame.

If the **top filler frame only is required**, insert trough assembly into top filler frame and locate front lower edge of trough flush with cabinet or optional height filler. Secure to the base cabinet using eight No. 10 x 5/8" PPHSMS through the side returns of the top filler frame into the front and rear returns of the base cabinet.

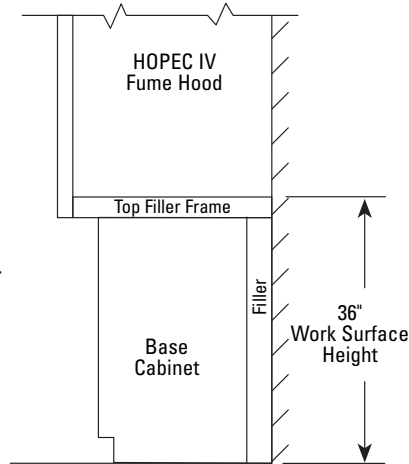

End view showing HOPEC IV fume hood, top filler frame and base cabinet.

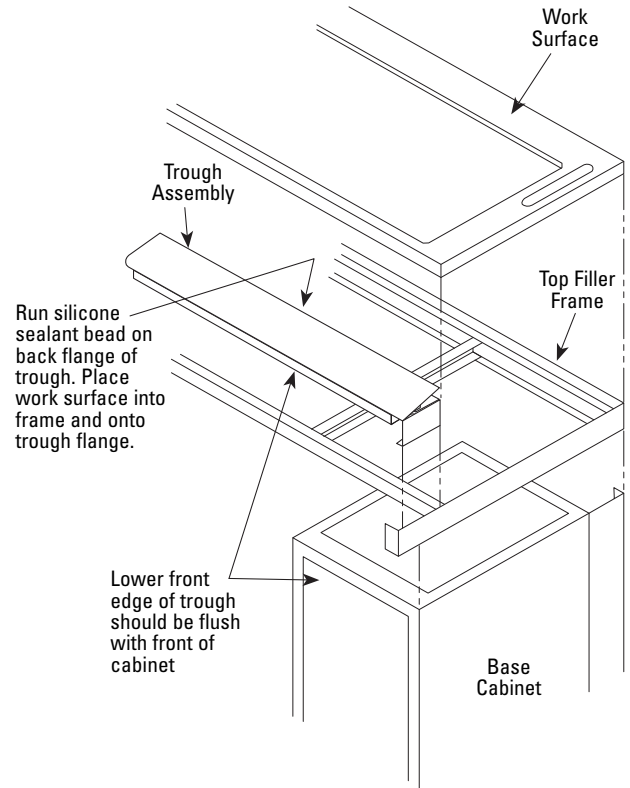

If the **optional height filler frame is required**, it is installed by aligning its bottom 3/4" return on the base cabinet and securing with four No. 10 x 5/8" PPHSMS screws. Insert trough assembly into top filler frame and locate front lower edge of trough flush with cabinet or optional height filler. Attach the top filler frame to the optional filler frame using eight No. 10 x 5/8" PPHSMS through the side returns of the top filler frame into the front and rear returns of the base cabinet.

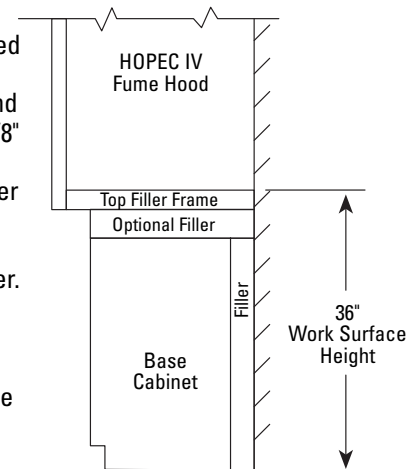

End view showing HOPEC IV fume hood, top filler frame, optional height filler and base cabinet.

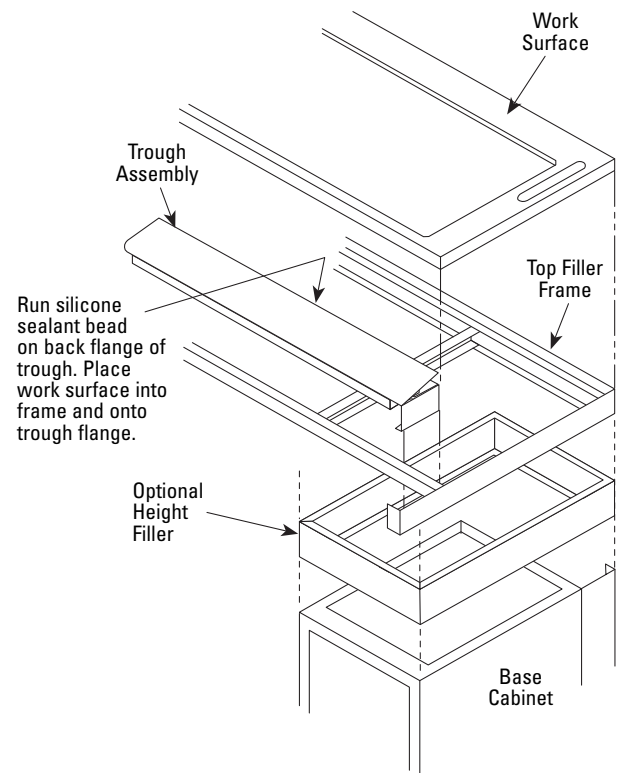

HOPEC IV Fume Hood Installation (continued)

3. Set the fume hood trough onto the top filler frame. The rear edge of the trough will set over the front horizontal rail and the return edge on the trough will secure it in place.

Note If a drain tube is required, it should be installed at this time. The tube is located at the left end of the trough and is fed through the top of the left hand base cabinet into a one gallon container.

4. Install poly vent, if required, through pre-drilled holes in the backs of base cabinets. The tail piece of the vent is supplied with a double compression assembly to lock it in place.
5. Seal the top edge of the trough assembly with a RTV silicon or other applicable sealer and then place the fume hood work surface into the top filler frame. If base cabinet poly vents are used, align them to the pre-cut holes in the work surface.
6. Install cupsinks if required. The fume hood base cabinets are supplied with pre-punched holes in the back panels above the stone liner for cupsink drains. Cupsink assemblies are supplied with the sink, an extension pipe, an elbow, and a pipe section that protrudes through the hole in the base cabinet back. The cupsink assembly is designed to fit two conditions.
 - A. When the fume hood assembly is supplied with the optional height filler frame, the cupsink assembly is fished through the sink cutout hole in the work surface and the drain line hole at the rear of the base cabinet.
 - B. When the fume hood is supplied with only the top filler frame, the extension pipe below the cupsink is removed to maintain alignment with the base cabinet rear drain hole. The pipe extension should be saved in the event that the optional height filler frame be required at a later date.
7. Move the HOPEC IV fume hood to the area of installation. Perform steps 1–10 on Page 6.

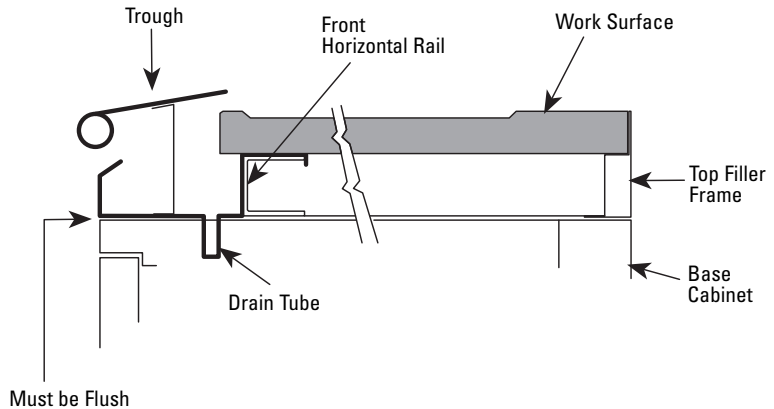

Baffle Installation and Adjustment

Two choices of baffle designs are offered:

1. Fixed.
2. Remote exterior control

Baffle Installation

Install baffles according to information on the next page.

See label located on right front post for remote exterior baffle **adjustment instructions**.

Baffle Adjustment

Thermo Scientific Hamilton fume hoods have two baffle settings:

- A.** Lighter-than-Air or high thermal loading.
- B.** Heavier-than-Air

Baffle position **A** is for lighter-than-air gases, or high heat loads. The top slot is open to maximize fume hood air flow in the upper portion of enclosure for efficient capture and exhaust of lighter-than-air fumes and hot gases.

The baffle at position **B** provides maximum air flow across the work surface for the collection and removal of fumes generated at the work surface and heavier-than-air gases.

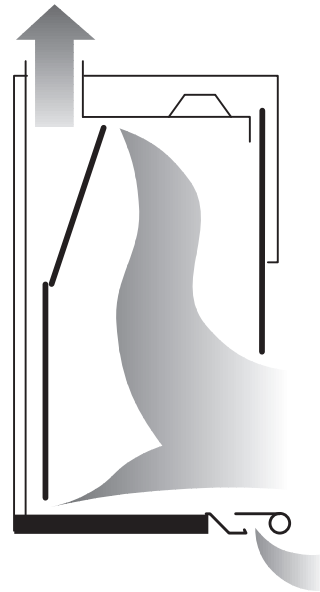

A – High Heat Loads or Lighter-than-Air Gases

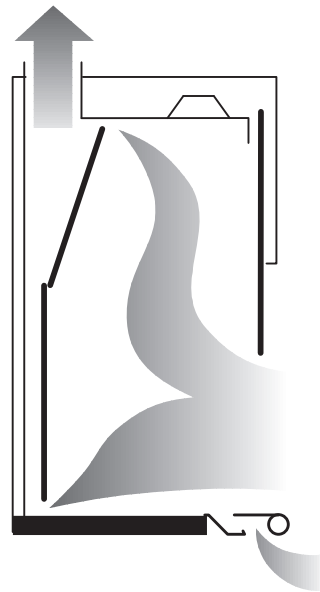

B – Heavier-than-Air Gases and Surface Fumes

Fixed Baffle Installation

Installing Fixed Baffle

1. Place upper baffle into position by engaging top edge into front exhaust collar extrusion. Lift baffle up and into upper support brackets to lock into position.
2. Place top edge of lower baffle into **front** slots on bottom edge of upper support brackets. Lift and lock baffle into the slot of lower support bracket.

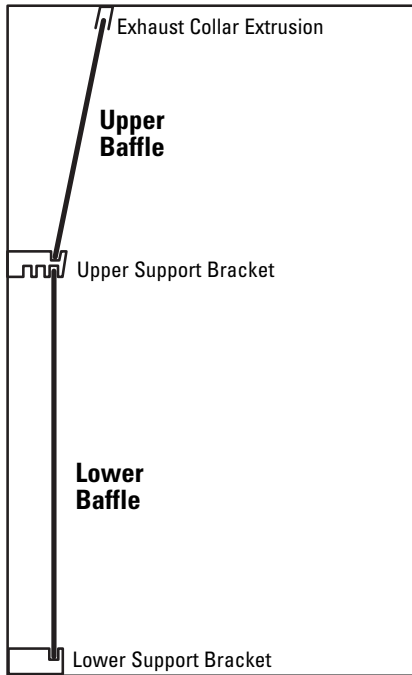

Remote Control Baffle Installation

Installing Remote Exterior Control Baffle

1. Place upper baffle into position by aligning forked slot of remote arm straight up and down. Slide upper baffle thru fingers of remote arm and drop into top slot of upper support bracket. (Baffle should be in front of exhaust collar extrusion).
2. Place top edge of lower baffle into **front** slots on bottom edge of upper support brackets. Lift and lock baffle into the slot of lower support bracket.

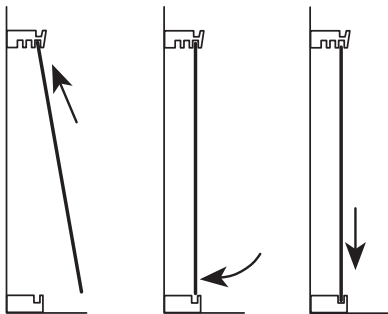
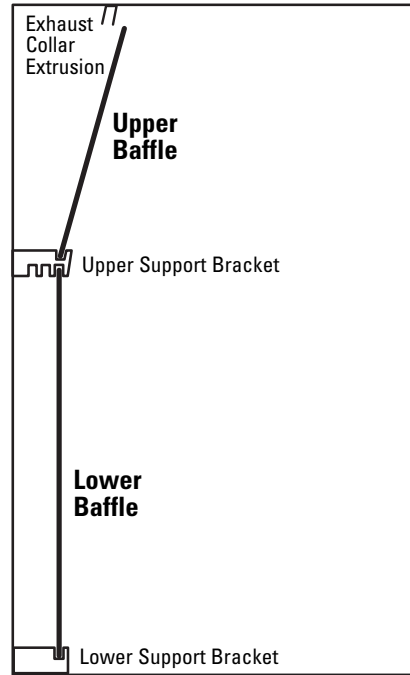

Installing Lower Baffle – Fixed and Remote

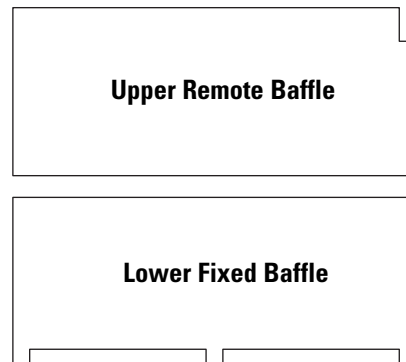

Attaching Blower Enclosure to Fume Hood

Hardware included:

- 1 Front panel
- 1 Front panel – removable
- 2 Side panels
- 2 Front support brackets
- 2 Rear support brackets
- 1 Bag assembly

Tools required:

- #2 Phillips screwdriver

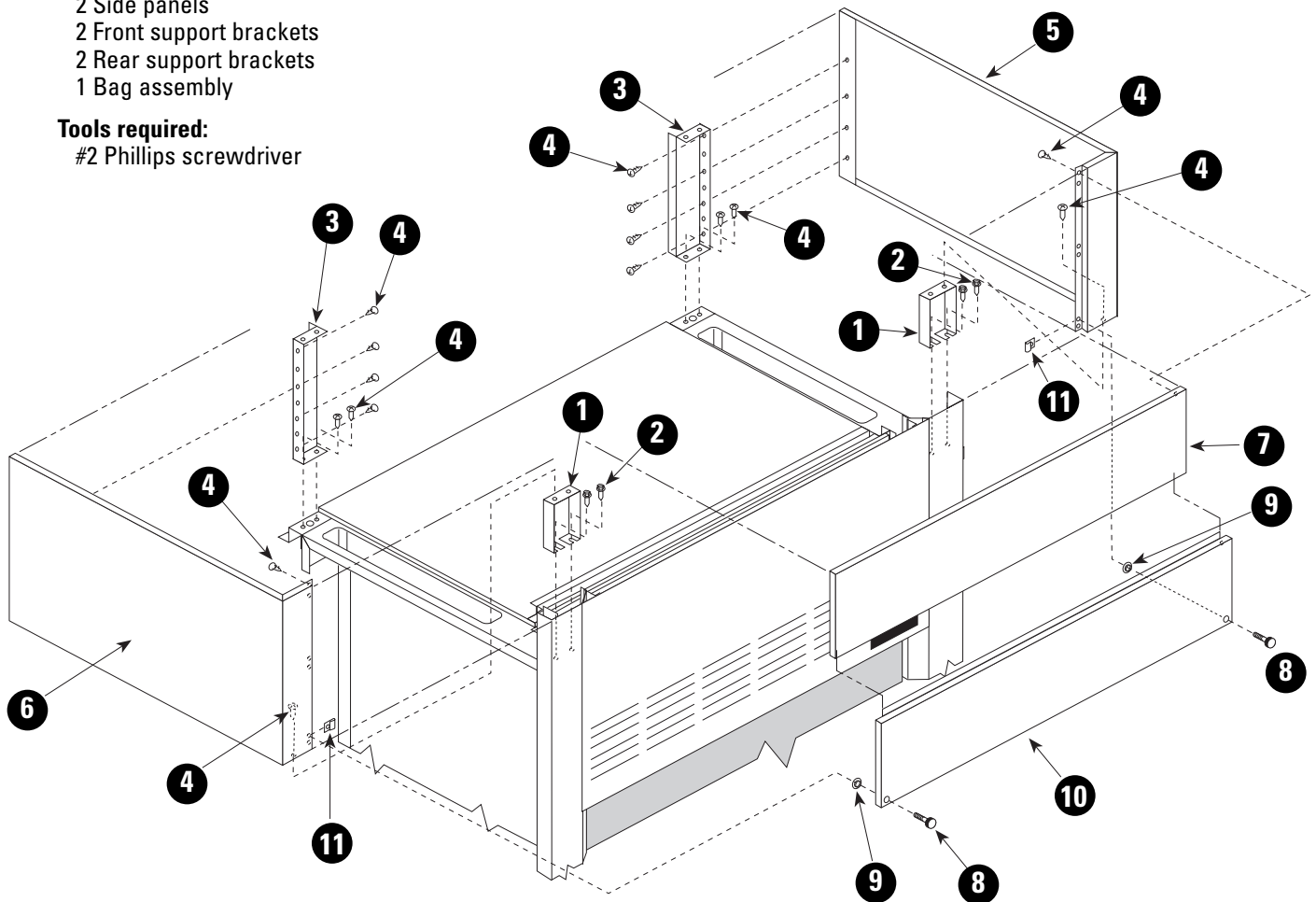

1. Fasten support brackets (1) in front top of frame assembly in holes provided. Use 1/4-20 x 3/4" hex head thread cutting screws (HHTCS) (2) furnished in bag assembly to fasten brackets.
2. Fasten rear support (3) to rear top of frame assembly. Use No. 8 x 5/8" Phillips pan head sheet metal screws (PPHSMS) (4) furnished in bag assembly.
3. Install right-hand (5) and left-hand (6) side panels to supports using No. 8 x 5/8" PPHSMS (4).

4. Install front panel (7) to side panels with No. 8 x 5/8" PPHSMS.
5. Subassemble thumb screws (8) and push retainers (9) to removable panel (10).
6. Insert hole fasteners (11) in larger hole in flange of side panels.
7. Insert top flange of removable panel under and behind front panel. Fasten thumb screws and tighten.

Fume Hood Monitor

Proper fume hood operation is key to laboratory safety, comfort and energy management. OSHA requires that laboratories take measures to ensure proper and adequate operation of fume hoods. Recommendations include the use of a continuous air monitoring device. The ANSI Z9.5 and NFPA 45 standards reinforce these requirements.

Fume hood monitors have the ability to monitor true fume hood face velocity using thermal sensors located in the instrument. The thermal sensors are exposed to clean laboratory air only. They can be surface-mounted in minutes eliminating the need for expensive panel cutouts.

Each model is equipped with indicator lights that illuminate based on a predetermined set-point. An audible 85dB piezoelectric alarm sounds and a red indicator light illuminates to warn of potentially dangerous low air flow conditions.

Fume hood monitors are shipped with operation manuals.

Filter Installation

The HEPA exhaust filter is an **optional** item.

Exhaust filter installation for product numbers 54L296, 54L297, 54L298 and 54L299

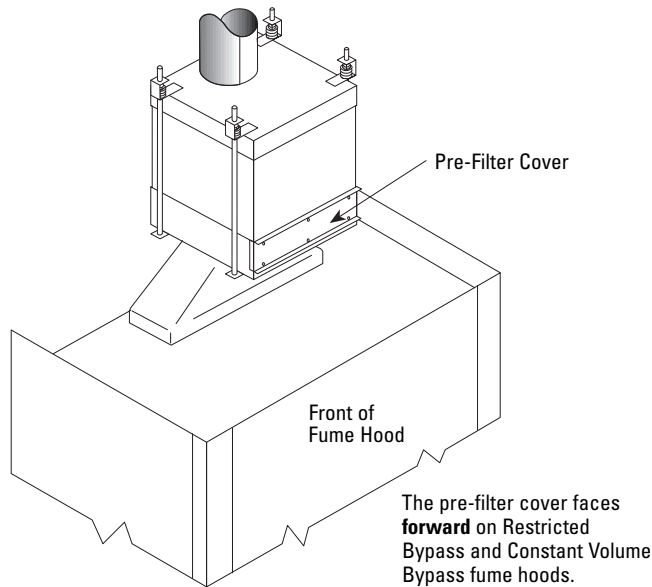

Securely attach the filter inlet collar to fume hood exhaust transition using same method as followed in the duct system. Filter outlet may be attached to duct using flexible connector or same as inlet connection.

Minihelic Gauge Installation

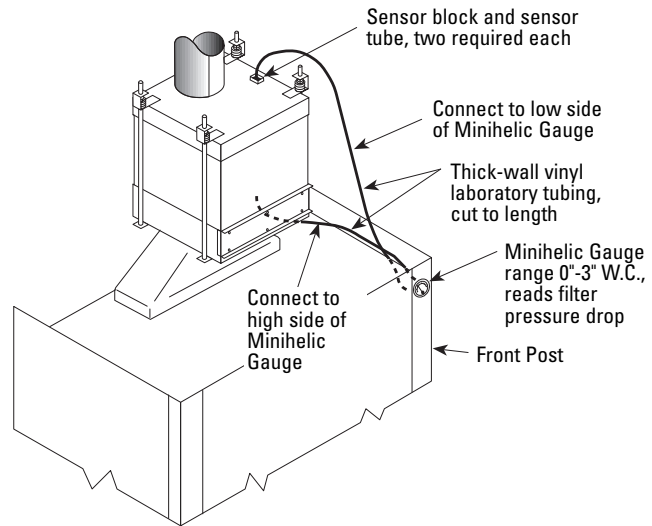

Replacement filter sets consist of one rough and one HEPA filter.

Product Number 54L302 – Filter set for 54L296 or 54L298.

Product Number 54L300 – Filter set for 54L297 or 54L299.

Warning and Operating Instructions

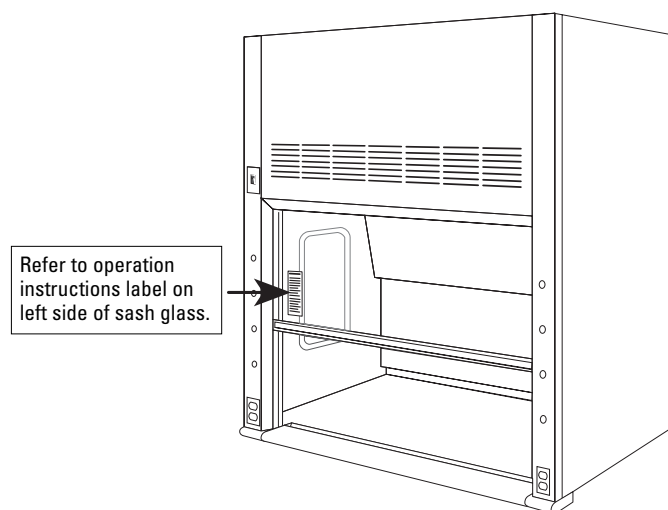

Warning

This product is intended for use with certain chemicals that can cause serious injury or illness through inhalation or physical contact. While this product is intended to minimize exposure to certain hazardous chemicals when selected, installed and operated properly, its performance and the safety of the user is affected by a number of factors. These include the HVAC system, the specific chemicals and processes being used, proper operation and the condition of the room.

Before using this fume hood, consult the owner's industrial hygienist or safety representative to ensure:

- 1) The specific fume hood alarms, controls and the HVAC system have been properly selected and are operating correctly;
- 2) The fume hood has been tested after installation and routinely thereafter to ensure the fume hood is providing the proper containment for the specific chemicals and processes being used;
- 3) There has been appropriate training on the correct use of the fume hood and handling of the specific chemicals and the fume hood operating instructions have been reviewed;
- 4) Any personal protective devices that are required are properly selected and provided;
- 5) The fume hood is being operated at the appropriate face velocity. The fume hood should never be operated with the sash in the full open position.

Operating Instructions

Failure to follow these instructions could result in physical injury or illness.

Caution: Do not use fume hood for perchloric acid procedures.

1. Do not use this fume hood unless you have received proper training from the owner's industrial hygienist or safety representative.
2. This fume hood is not intended to be used with all chemicals or all chemical processes. Consult the owner's industrial hygienist or safety representative to determine whether the fume hood is appropriate for the chemicals and processes to be used.
3. Verify that the fume hood exhaust system and controls are operating properly and providing the necessary air flow. If in doubt, the owner's industrial hygienist or safety representative should be consulted. It is recommended that the fume hood be equipped with an air flow monitoring device. Before using the fume hood, verify that the monitor is operating properly by testing the monitor.
4. The fume hood should not be operated with the sash in the full open (setup) position. When the fume hood is in use, the opening of the sash glass should be kept at a minimum. On a vertical rising sash, the sash glass should be no higher than 18". The sash should remain closed when the fume hood is not in use.
5. Place chemicals and other work materials at least six (6) inches inside the sash.
6. Do not restrict air flow inside the fume hood. Do not put large items in front of the baffles. Large apparatus should be elevated on blocks. Remove all materials not needed for the immediate work. The fume hood must not be used for storage purposes.
7. Never place your head inside the fume hood.
8. External air movement can affect the performance of the fume hood. Do not operate near open doors, open windows or fans. Avoid rapid body movements. Do not open the fume hood if there are cross drafts or turbulence in front of the hood. Do not open the sash rapidly.
9. Wear gloves and other protective clothing if contact with contaminants is a hazard.
10. Clean spills immediately.
11. If fumes or odors are present, stop operating the fume hood, close the sash and contact the owner's industrial hygienist or safety representative immediately.
12. It is recommended that this fume hood be tested and certified annually by the owner according to applicable industry and government standards.

General Maintenance of Fume Hoods

Fume hood maintenance procedures consist primarily of cleanup, adjustment, lubrication, and replacement of worn, damaged or non-functioning parts. Lubrication of sash guides, cables, pulley wheels, and other working parts should be accomplished as required and replacement of broken, worn, or non-functioning parts as needed. The following items should be **inspected and serviced at least semi-annually**:

- Liner and baffles for condition and cleanliness.
- Low air flow detectors.
- Service fixtures and lights.
- Pulleys and belts.
- Sash operation and counterbalance cables including a complete visual check of the entire system.
- Make sure there is a 1/16" clearance between cable keepers and pulley sheaves.
- Velocity and pressure sensing detectors.
- Low or no flow alarms, both visible (lights) and audible (horns or bells).
- Signal transmission for alarms designed to activate signals at more than one location.
- Instrument verification of fume hood face velocity and determination of usage by observation and interview.
- Ductwork and blower.

Warning (For Perchloric only)

Use only fluorocarbon grease on blower since any other type is to be considered potentially dangerous.

Warning

Frayed or broken cables should be replaced to avoid personal injury or damage to fume hood. Not all cable manufacturer's cables are the same quality and cycle life. Only Thermo Scientific Hamilton cables are warranted.

Cleanup should be accomplished by, or under the supervision of, a knowledgeable technician and should include removal of all baffles for cleanup of all interior surfaces.

Flush all spills immediately using neutralizing compounds as required and clean thoroughly. Use good housekeeping in laboratory fume hoods at all times.

Fume Hood Inspection Procedures

Safety considerations require that a schedule of inspection and documentation be setup for every laboratory fume hood at least annually.

An inspection record should be maintained. This record may be in the form of a label attached to the fume hood, or a log held by the laboratory director or health safety director.

Inspection procedures should include instrument verification of fume hood face velocity and a determination of usage by observation and interview. These procedures should also consist of a physical examination of liner condition and cleanliness, baffle and sash operation and condition, counterbalance cables, light operation and condition, and service fixture function.

Inspection results should be recorded and reported to the proper authority for any required action.

Special purpose fume hoods such as those used with radioactive materials or perchloric acid require additional inspection procedures to cover special equipment and requirements.

Options, such as low air flow detectors, when installed, should be inspected at least annually. Where extreme hazardous or corrosive conditions exist or when filters are present in the system, the inspection frequency should be increased appropriately. Velocity and pressure sensing detectors should be tested at each inspection. Low-flow or no-flow alarms of the visible (lights) or audible (horns or bells) type should be tested for correct operation at least at each inspection. Signal transmission for alarms designed to activate signals at more than one location should be verified at each location during each inspection. Frayed or broken belts should be replaced promptly.

Cleaning Fume Hood Interiors

Fume hood liners are maintained by an occasional washdown with detergent and warm water. Stains and salt deposits can be removed with a weak acid solution (5%) or an appropriate solvent – **DO NOT USE ACETONE**. Remove baffles for access to all surfaces. See Page 10 for removal and installation procedures.

The use of organic chemicals or materials in a specialized perchloric acid fume hood with a stainless steel interior should be avoided.

Fluorescent Light Tube Replacement – Bench Top and Hi-Line Fume Hoods

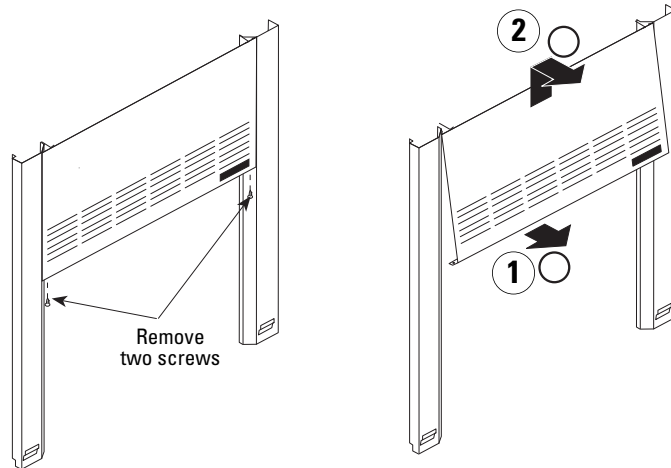

1. Remove sash enclosure if applicable.
2. Remove two screws securing bottom of front panel to front corner posts. Pull front panel up to disengage from studs and remove panel.
3. Squeeze bottom edge of lamp housing to disengage from galvanized channel. Rotate lamp housing up to expose bulbs. Replace bulbs with same type as in unit. Turn on light switch to verify connections.
4. Reverse Steps 1-3 to return fume hood to usable condition.

Fume Hood Service Fixtures

Removal of Access Panel

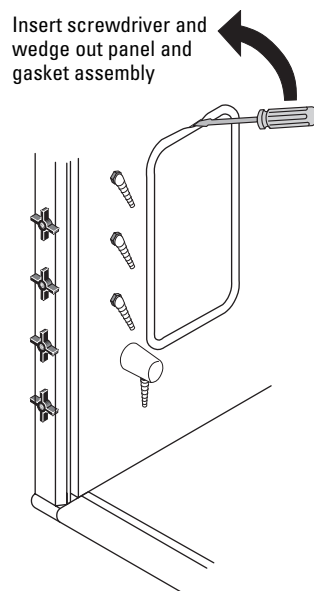

Installation of Access Panel

Twist the corners of gasket towards cutout before insertion. Replace the panel and work the entire periphery of the gasket to be sure that the gasket is completely snapped into position. Gasket should be smooth and tight when properly seated.

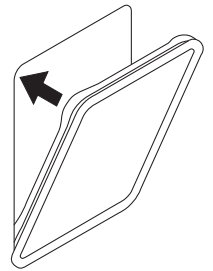

The fixtures used within fume hoods are needle valve type, and if they wear, stainless steel cone and seat replacement kits can be ordered through your sales representative. It is necessary to remove the handle from the valve and then remove the valve mechanism. This can be done through the access panels (shown above) if fixtures are mounted in the superstructure, or from inside the cupboard if the fixtures are deck mounted.

Access to the valves by removal of the exterior end panels (Step 1 on Page 6) permits seat replacement without the need to remove the valve. This approach is recommended when ends are exposed and accessible.

Access to service fixture valves on fume hoods without access panels is obtained by removal of the exterior end panels (Step 1 on Page 6) when fume hoods are free-standing.

Access Through Front Posts

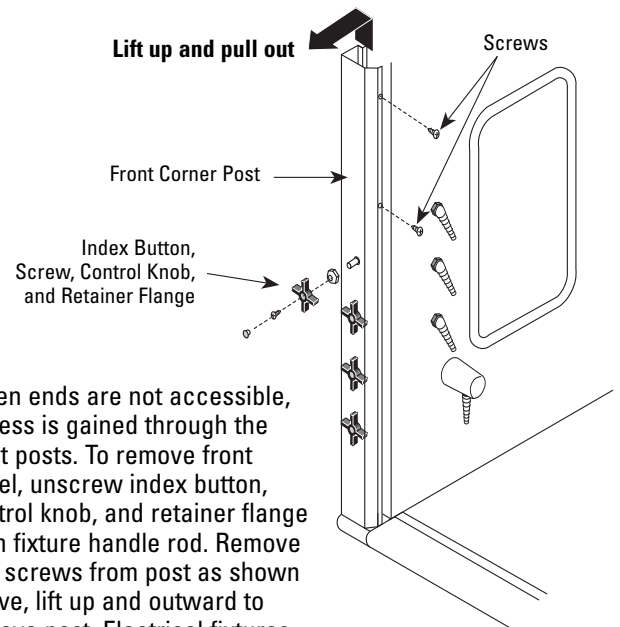

When ends are not accessible, access is gained through the front posts. To remove front panel, unscrew index button, control knob, and retainer flange from fixture handle rod. Remove two screws from post as shown above, lift up and outward to remove post. Electrical fixtures are connected to post with flexible conduit and can remain attached.

Framed Glass and Cable Replacement

Special parts, options, and accessories should be maintained as required.

Sashes occasionally require service. The glass may fog due to the condensation of chemical vapors, and such materials should be removed promptly by washing with water and detergent to prevent etching of the glass.

Warning

If cable is frayed or damaged, it **MUST** be replaced to avoid personal injury or damage to the fume hood

Framed Glass and Cable Replacement

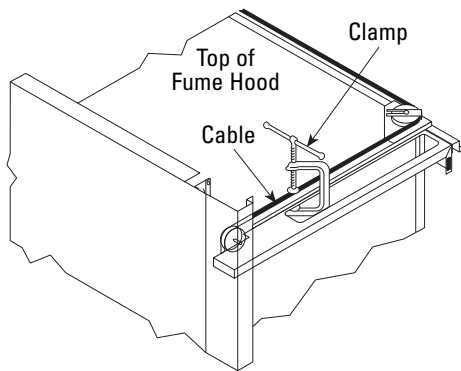

1. Hold the sash in the closed/down position by clamping the sash counterbalance cable to the top structural frame member. In some situations, access to the top of the fume hood may be gained by:
 - Removing end panel if end of fume hood is clear – See Page 6.
 - Removing front louver panel – See Page 15.
 - Removing blower enclosure panels – See Page 11.

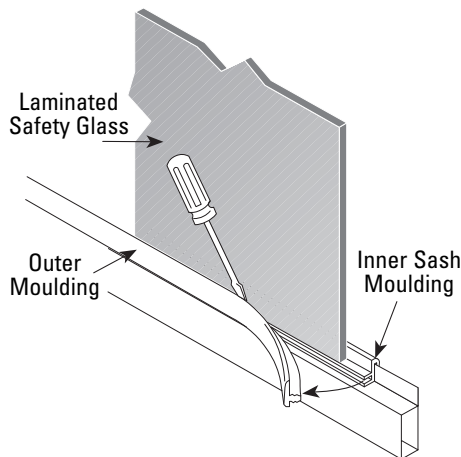

2. Remove the outer portion of the sash moulding strip on all four sides of the frame. Use a flat blade screwdriver to pry away from inner portion of moulding. Dispose of broken and both portions of the sash moulding strip.

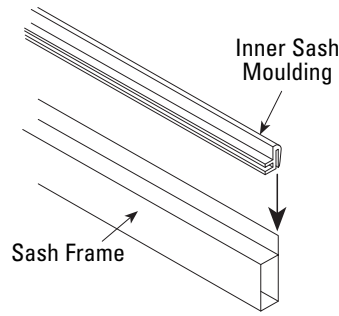

3. Press the four sections of the inner sash moulding strip over the sash frame edge.

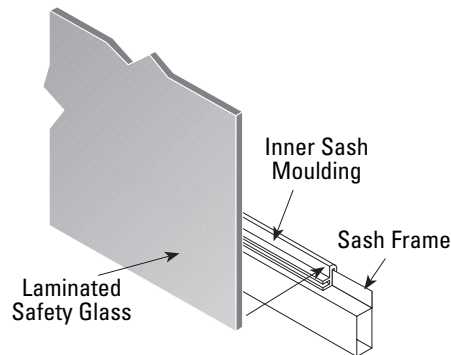

4. Place the new sash glass onto the inner sash moulding and hold in place.

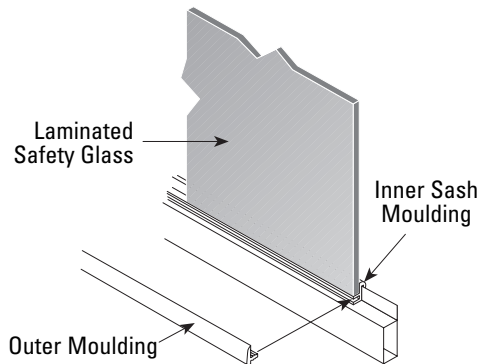

5. Press the outer moulding strip into the groove of the inner strip.
6. Remove clamps holding the sash cable in place and test for balance.

Cable Replacement

1. Sash counterbalance cable is replaced by removing front corner post (See Page 15) for access. Field repairs can be made on existing cable if the problem is an end fastening device or disconnection. If cable is frayed or broken, order replacement cable – describe hood type, size and cable length.

Sash Glass Replacement – Fume Hoods already Installed

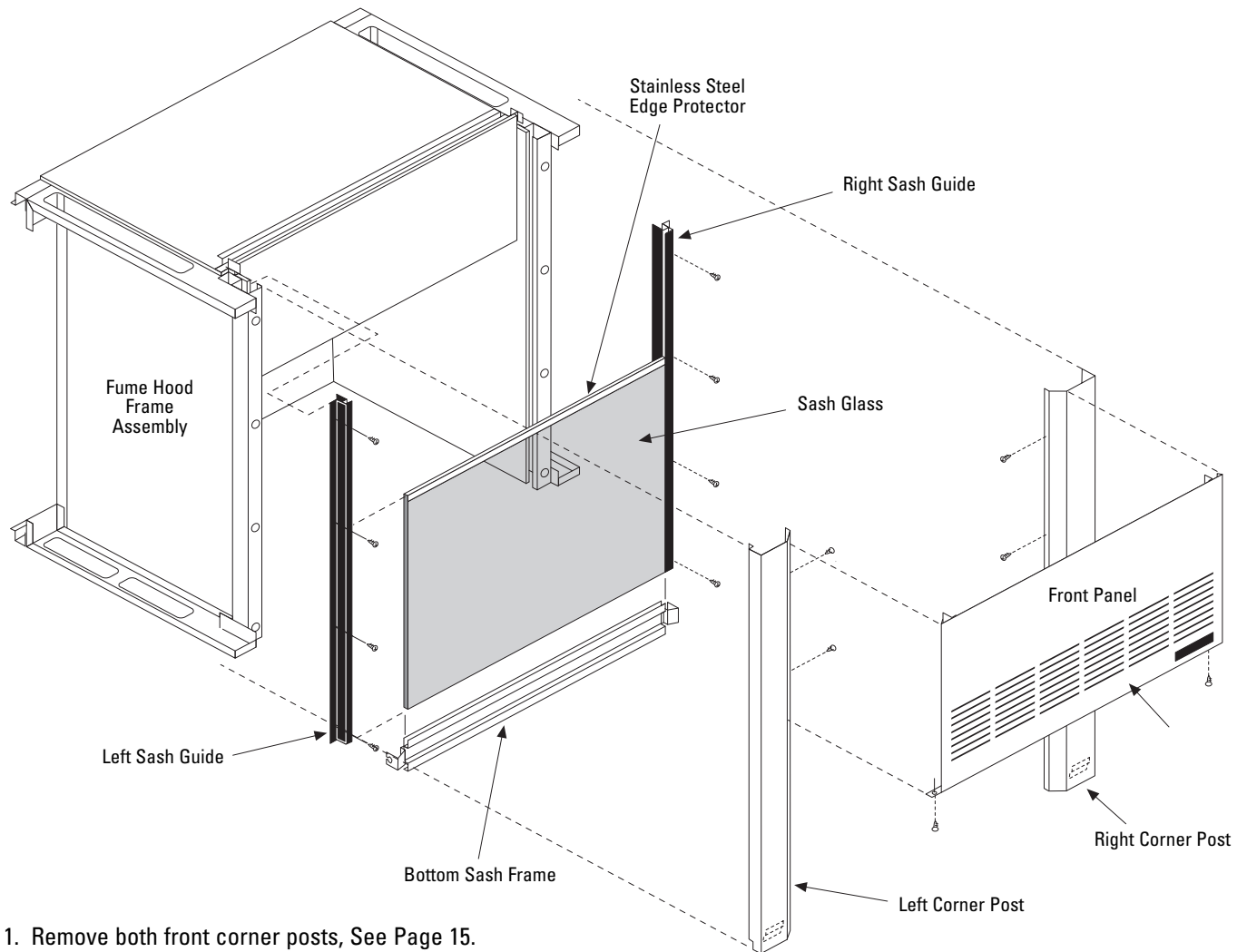

1. Remove both front corner posts, See Page 15.

Warning

If cable is frayed or damaged, it **MUST** be replaced to avoid personal injury or damage to the fume hood.

2. After removal of one of the corner posts, clamp the sash cable to the top of the side frame assembly. See page 16.
3. Remove screws that hold the sash guide to the front frame upright and slide the guide up and away from the sash. **Care should be taken when the sash guide is removed so that the glass does not fall from the remaining guide.**

**Sash Glass Replacement –
Fume Hoods already Installed (continued)**

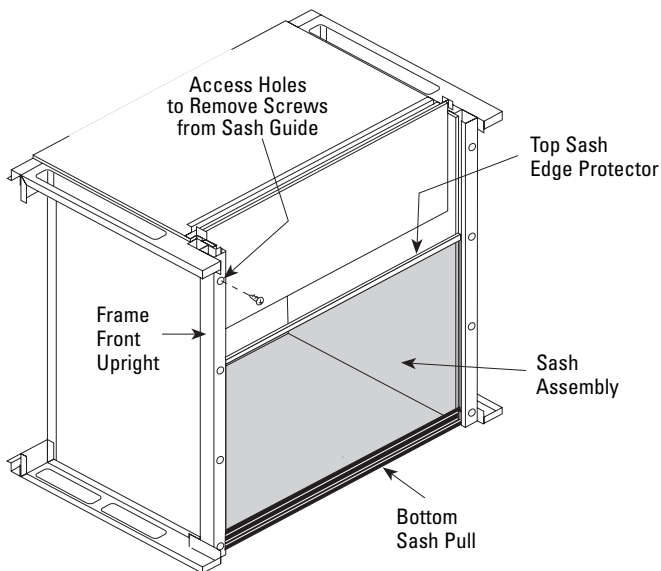

4. While holding the sash glass, first remove the upper stainless steel edge protector. Then force the glass from the bottom sash pull by pulling upward while holding the sash pull in place. At this point the glass and gasket material should come loose, the bottom sash frame remains attach to the sash cables and one sash guide.
5. Place gasket material on the bottom of the new sash glass. Align with the bottom frame member and press into place. Replace the stainless steel edge protector on the top horizontal edge of the glass. Replace the sash guide and remove clamps holding the sash cables. Move the sash up and down to test for proper alignment in the sash guides. If at this point you notice the glass is not completely seated into the bottom frame member, tap gently on the bottom with a rubber mallet to seat the glass.
6. Replace the front corner posts and the front panel.

Optional Exhaust Filter Replacement

Warning

Wear adequate protective devices and use techniques to prevent contamination of the laboratory environment. Filter exchange should be accomplished by knowledgeable personnel who perform sterilization procedures or are trained for the safe handling of radioactive materials if used. Some users prefer to wet the filter media with a steam or aerosol generator to increase adhesion of particles.

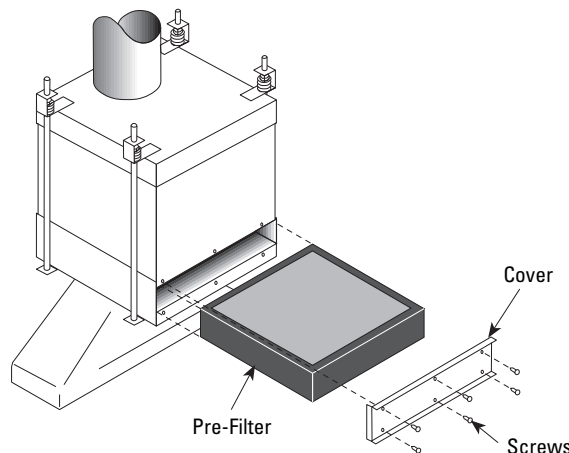

To remove pre-filter, remove six screws that secure the pre-filter cover. Slide the filter out. Slide new filter into the housing and secure cover in place.

To remove final filter, loosen the nuts above the springs to unclamp the filter. Continue turning the nuts until they contact the upper flange of the spring bracket and lifts the plenum away from the filter approximately 1/8 inch.

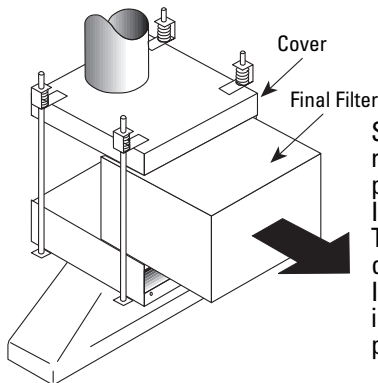
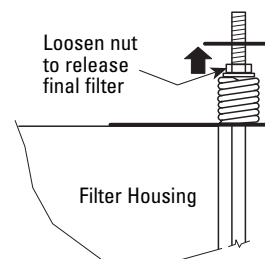

Slide the old filter out (the rods will support the upper plenum and duct work). Insert the new final filter. Turn the four nuts down to compress the springs. Inspect seal after installation and periodically thereafter.

Blower RPM Adjustments

1. Remove housing over motor blower assembly.
2. Loosen the four bolts [A] which hold the motor mounting plate stationary so that the plate has a vertical movement, as shown in illustration below. This should be done so that a later adjustment for correcting belt tension can be made.
3. Make all adjustments **ONLY** with the outside half sheave [B] on the driving shaft.
4. To increase the RPM of the blower, increase the diameter of the driving sheave by loosening the Allen screw [C] and turning the outside half-sheave toward the motor. Tightening the Allen screw to the flat portion of the threaded shaft then fixes the diameter of the sheave.
5. To decrease the RPM of the blower, decrease the diameter of the driving sheave by loosening the Allen screw [C] and turning the outside half-sheave away from the motor. Tightening the Allen screw to the flat portion of the threaded shaft then fixes the diameter of the sheave.
6. Correct belt tension (side play 1/2" to 3/4") can now be set by adjusting the loosened motor mounting plate and tightening the four bolts.

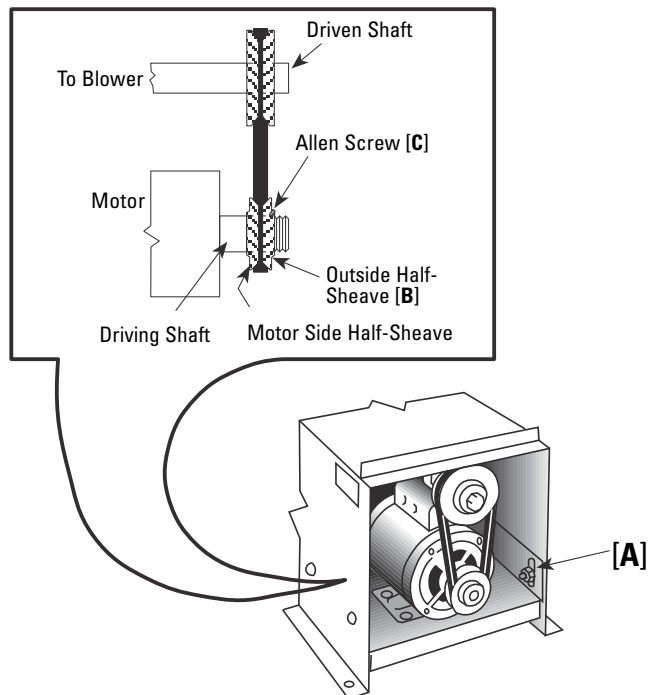

Terminology

Sheave = Pulley

Driven = Attached to blower shaft

Driving = Attached to motor shaft

Monitoring Exhaust Filters Using a Manometer

When a filter device is installed on a fume hood exhaust system, it is important that the filter performance and condition be monitored to ensure proper performance of the filter and of the fume hood to which it is connected.

By measuring the pressure drop across the filters, the manometer assembly will provide information on filter function and condition.

Manometer reading with clean filters should be recorded and marked with grease pencil on the face of the unit. When the reading changes by one inch, replace filter(s). A maintenance schedule should be setup for periodic reading of the manometer. Frequency can be determined by usage.

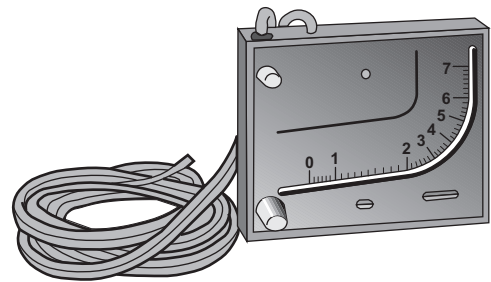

Any change in manometer reading should be investigated. It may indicate filter damage, over-pressure, or an unsafe operating condition. If it is subjected to an over-pressure, disassemble and examine for fluid in loops and tubes. Drain and re-install per instructions.

The manometer assembly requires a periodic cleaning of the exterior with water or naphtha and inspection and adjustment of the oil level. Adjust micrometer knob for zero reading as required. Add oil as needed to maintain zero reading.

Proper use of the manometer assembly provides a continuous indication of filter and operation conditions.

Be sure to remove manometer when changing filters.

Fume Hood Evaluation in the Field

It is recommended that the user make provisions to have the following tests performed on all laboratory fume hoods. These tests should be performed by qualified personnel to verify proper operation of the fume hoods before they are put to use. The tests of the fume hoods should be performed after the installation is complete, the building ventilation system has been balanced, and all connections made. Any unsafe conditions disclosed by these tests should be corrected before using the fume hood.

Test Procedures

Test Conditions

Verify that building make-up air system is in operation, the doors and windows are in normal operating position, and that all other fume hoods and exhaust devices are operating at designed conditions.

Room Conditions

Check room condition in front of the fume hood using a thermal anemometer and a smoke source to verify that the velocity of cross drafts does not exceed 20% of the specified average fume hood face velocity. Any cross drafts that exceed these values shall be eliminated before proceeding with the fume hood test.

Equipment List

- (a) A properly calibrated hot-wire thermal anemometer.
- (b) A supply of 1/2 minute smoke bombs.
- (c) A bottle of titanium tetrachloride and a supply of cotton swabs or other recognized device for producing smoke.

CAUTION

Titanium tetrachloride fumes are toxic and corrosive. Use sparingly, avoid inhalation and exposure to body, clothing and equipment.

It must be recognized that no fume hood can operate properly if excessive cross drafts are present.

Face Velocity

Determine specified average face velocity for the fume hood being tested. Perform the following tests to determine if fume hood face velocities conform to specifications. With the sash in normal operating position, turn ON the exhaust blower. The face velocity shall be determined by averaging the velocity of six readings taken at the fume hood face. Readings shall be taken at the centers of a grid made up of three sections of equal area across the top half of the fume hood face and three sections of equal area across the bottom half of the fume hood face.

If not in accordance with specified face velocity, refer to Troubleshooting section on Page 23, for aid in determining the cause of variation in air flow. If face velocity cannot be corrected to that which is specified, reclassify fume hood to conform to actual face velocity. Shut off auxiliary air when testing an Auxiliary Air fume hood.

Sash Operation

Check operation of the sash by moving it through its full travel. Sash operation shall be smooth and easy. Vertical rising sashes shall hold at any height without creeping up or down.

Air Flow

Fume Hoods

Turn fume hood exhaust blower on. With sash in the open position, check air flow into the fume hood using a cotton swab dipped in titanium tetrachloride or other smoke source. A complete traverse of the fume hood face should verify that air flow is into the fume hood over the entire face area. A reverse flow of air indicates unsafe fume hood operation. Consult the Troubleshooting section on Page 23, for possible causes and take corrective action. Move a lighted smoke bomb throughout the fume hood work area directing smoke across the work surface and baffle. Smoke should be contained within the fume hood and be rapidly exhausted.

Low Air Flow Monitor

On fume hoods with low flow warning devices, verify that monitor functions properly and indicates unsafe conditions.

Fume Hood Testing**ANSI/ASHRAE 110-1995**

The performance of a laboratory fume hood in providing protection for the worker at the face of the fume hood is strongly influenced by the laboratory room ventilation, and by other features of the laboratory in which it is installed. Therefore, there arises a need for a performance test which can be used to establish an "as manufactured" and an "as used" performance rating, including the influences of the laboratory arrangement and its ventilating system.

The test presumes a conditioned environment. No test can be devised which, regardless of frequency, reflects the results obtained in a non-conditioned laboratory with various conditions of windows, wind velocity, etc.

This procedure is a performance test method.

It remains for the user, the hygienist, or the applications engineer to specify what level of fume hood performance is desired or required. It should be noted that the performance test does not give a direct correlation between testing with a tracer gas and operator exposures. Many factors, such as the physical properties of the material, the rate and mode of evolution, the amount of time the worker spends at the face of the fume hood, and several other factors must be integrated, by a trained observer, into a complete evaluation of worker exposure. The performance test does, however, give a relative and quantitative determination of the efficiency of fume hood capture under a set of strict, although arbitrary, conditions. The same test can be used to evaluate fume hoods in the manufacturer's facilities under (presumable) ideal conditions, or under some specified condition of room air supply.

The test may be used as part of a specification once the appropriate release rate and required control level are determined. If so used, an "AM" (as manufactured) specification places a responsibility on the fume hood manufacturer, and an "AU" (as used) specification places responsibilities on others, viz., the designer of the room air supply, the designer of the room layout, etc.

The test sheet attached to the fume hood reflects fume hood performance parameters. This sheet represents "AM" testing.

It is recommended that the ASHRAE 110-1995 test procedure be subjected to this fume hood under "AU" (as used) conditions.

Refer to the ASHRAE Standard 110-1995 or contact Thermo Scientific Hamilton for further information.

If, for some reason, the above test cannot be performed at the job site, use of the SEFA-1.2 1996 test procedure as minimal proof of proper fume hood performance is suggested.

This test consists of a face velocity grid test and a smoke test procedure.

Information and copies of this procedure are available from Thermo Fisher Scientific.

Semi-annual verification that this above criteria is subjected to and met by all fume hoods at your particular facility is recommended.

Field Evaluation of Laboratory Fume Hoods

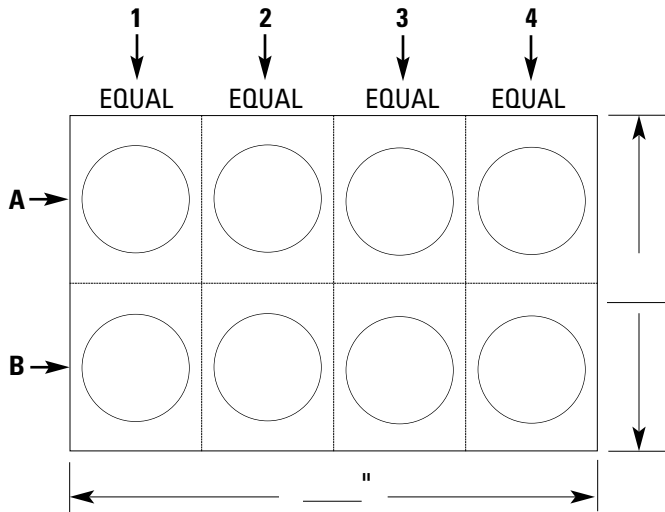

Project Name _____

Location _____

Order Number _____

Room _____ Item _____

Fume Hood Identification _____

Sash Operation _____

Light Operation _____

Baffle Operation _____

Services: A G V W NIT. Steam

Other _____

Conclusion & Comments _____

Face Velocity Test

Square footage of fume hood opening _____

Plus bypass _____

Total _____

1A _____ FPM

1B _____ FPM

2A _____ FPM

2B _____ FPM

3A _____ FPM

3B _____ FPM

4A _____ FPM

4B _____ FPM

TOTAL 8 = _____ avg.

TOTAL CFM = (Avg. x Sq. Ft. of open sash & any bypass)

Alarm Condition: Functional _____

Non-Functional _____

Smoke Test: Positive _____

Negative _____

I certify that the above results were obtained on _____ by _____

Evaluation procedures conducted by _____
Name Title

When fume hood test procedures detect an improper function, the cause is typically due to:

- a) Insufficient quantity of air flowing through the fume hood;
- b) Room cross drafts blowing into or across the face of the fume hood; or
- c) A combination of (a) and (b).

Following are suggestions to troubleshoot the problem.

■ Room Cross Drafts

Air moving through an open door located adjacent to the fume hood can cause cross drafts. An open window or a room air supply located to one side or across from the fume hood can also cause disturbing cross drafts.

High velocity air from ceiling-mounted diffusers can cause a flow of air down and into the top half of the fume hood face that can cause reverse flows of air out of the bottom half of the face.

■ Insufficient Air Flow

One or more of the following conditions may exist; each condition should be checked and eliminated if possible, to determine what conditions may exist:

- a) Inaccurate face velocity readings. Check airflow velocity meter type. Is the instrument recommended for low air velocities in the 50 to 100 feet per minute ranges? When was it calibrated last?
- b) Verify readings with another air velocity meter or by checking air volume using a pitot tube traverse or exhaust duct.

Before contacting a service rep to assist with troubleshooting, answering the following questions will help identify where the problems have originated.

Who stated that the unit did not operate properly?

- What is their position?
- Who are they employed with?

What tests were performed?

- Instruments used?
- When was it calibrated?
- What were the results?

What is the fume hood type?

- What is the model?
- What is the size?

Is the location of fume hood acceptable?

Are cross currents present?

- Is there traffic past fume hood?

Is adequate free or make-up air available?

- Is it always available?
- What is the supply source?
- Can it be altered or cut off?

Did the fume hood ever function properly?

- Have authorized modifications been made?

Have recent changes been made in the laboratory heating/cooling system?

- Describe.

DO NOT DISCARD IMPORTANT TEST AND CALIBRATION DATA ENCLOSED!

TO BE REMOVED ONLY BY FUME HOOD USER

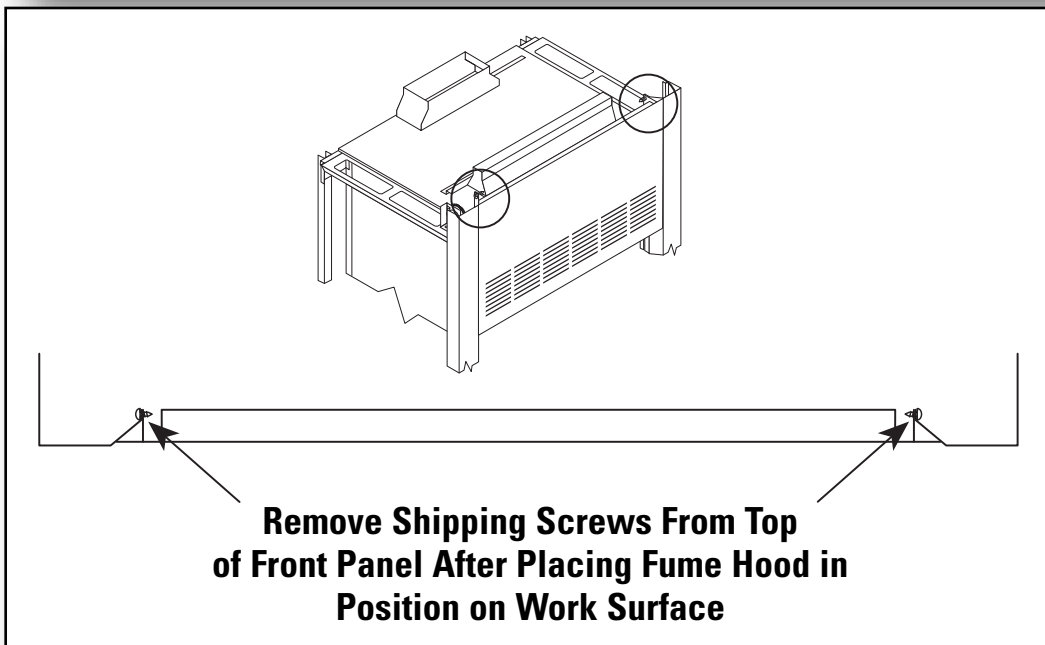

© 2010 Thermo Fisher Scientific Inc. All rights reserved. All trademarks are the property of Thermo Fisher Scientific Inc. and its subsidiaries. Specifications, terms and pricing are subject to change. Not all products are available in all countries. Please consult your local sales representative for details.

Laboratory Furniture
and Fume Hoods

1316 18th Street

Two Rivers, WI
54241

920-793-1121

www.thermoscientific.com/hamilton

PL-1012 0610

Thermo
SCIENTIFIC