

# INSTRUCTIONS

## IMT-2

---

### INVERTED RESEARCH MICROSCOPE

---

*This instruction manual has been written for use of the Olympus Inverted Research Microscope Model IMT-2. Before putting the microscope into operation, it is recommended that you read this manual carefully in order to familiarize yourself fully with the use of this microscope so that you may obtain optimum performance of this instrument.*

# OLYMPUS

# BEFORE USE

Observe the following points carefully for operation and maintenance:

## 1. Operation

- ① As a microscope is a precision instrument, always handle it with the care it deserves, and avoid abrupt motions and shocks.
- ② To lift the microscope from the packing case, hold it at the OM mount (A) and the fluorescence illuminator mounting thread (B). (Fig. 1)
- ③ To move the microscope  
Hold the microscope by the OM mount (A) and the fluorescence illuminator mounting thread (B) or place your hands under the microscope base at the microscope side (C) and back (D).  
Do not grasp the plastic hand rests, since they are not strong enough to support the microscope.
- ④ Do not use any bulb other than the one designated by Olympus (12V50W HAL halogen bulb).
- ⑤ Avoid exposure of the microscope to direct sunlight, high temperature and humidity, dust and vibration.
- ⑥ Make it a point to use the tension adjustment ring to adjust the tension of the coarse adjustment knobs. (Do not rotate the coarse adjustment knobs in the opposite directions simultaneously.)
- ⑦ Make sure that the line voltage selector switch is set to conform with the local mains voltage.
- ⑧ Disconnect the power cord from the AC outlet before fuse replacement.
- ⑨ Always ground the microscope.



Fig. 1  
(Model IMT2-SFR shown)

## 2. Maintenance

- ① Lens surfaces must always be kept clean. Fine dust on lens surfaces should be blown off by means of a hand blower. Carefully wipe off oil or fingerprints on the lens surfaces with gauze moistened with a small amount of xylene, or a cleaning medium (alcohol and ether 3 : 7).
- ② Do not use organic solutions to wipe the surfaces of various plastic components.
- ③ Be careful not to spill the culture solution, etc. If spilt, it should be wiped off immediately. It is recommended to use a waterproof cover optionally available.
- ④ When objectives are not screwed into the nosepiece apertures, seal the apertures with dust plugs, which will protect the lenses located in the lower light path from dust, culture solution, etc.
- ⑤ After use the microscope should be covered with the vinyl dust cover provided and stored in a place free from humidity.

# CONTENTS

|                                              |    |          |
|----------------------------------------------|----|----------|
| 1. SPECIFICATIONS                            | 1  | <b>1</b> |
| 2. STANDARD CONFIGURATIONS                   | 2  | <b>2</b> |
| 3. NOMENCLATURE                              | 3  | <b>3</b> |
| 4. ASSEMBLY                                  | 5  | <b>4</b> |
| 5. OPERATION                                 | 10 | <b>5</b> |
| 5-1 Observation Procedure .....              | 10 |          |
| 5-2 Operation of Individual Components ..... | 11 |          |
| 6. PHOTOMICROGRAPHY                          | 18 | <b>6</b> |
| 6-1 Photomicrographic System .....           | 18 |          |
| 6-2 Taking Pictures .....                    | 20 |          |
| 7. TROUBLESHOOTING GUIDE                     | 22 | <b>7</b> |

# SPECIFICATIONS

| Item                | Specifications                                                                                                                                                                                                                                                                                         |                                                                                                                                                                                                   |                         |
|---------------------|--------------------------------------------------------------------------------------------------------------------------------------------------------------------------------------------------------------------------------------------------------------------------------------------------------|---------------------------------------------------------------------------------------------------------------------------------------------------------------------------------------------------|-------------------------|
| Microscope stand:   | Focus adjustment by vertical movement of the nosepiece (stage is fixed in position) by means of the coaxial coarse and fine adjustment knobs; roller guide stroke (from the focal point on the stage surface): 8 mm upward and 2 mm downward; with reduction gear, graduated in increments of $2\mu$ . |                                                                                                                                                                                                   |                         |
| Nosepiece:          | Sextuple, with provision for mounting the Nomarski slider attachment; detachable.                                                                                                                                                                                                                      |                                                                                                                                                                                                   |                         |
| Stage:              | Cross-movement stage IMT2-SVR                                                                                                                                                                                                                                                                          | 200 mm x 200 mm, traversing area 50 mm x 50 mm; with low positioned coaxial control knobs; 2 insert plates, outside diameter 110 mm, inside diameters 20 mm and 50 mm respectively.               |                         |
|                     | Cross-movement stage IMT2-SFR                                                                                                                                                                                                                                                                          | 200 mm x 200 mm, traversing area 50 mm x 50 mm; with low positioned coaxial control knobs; 2 insert plates, outside diameter 110 mm, inside diameters 20 mm and 50 mm respectively, low flexible. |                         |
|                     | Square plain stage IMT2-SP                                                                                                                                                                                                                                                                             | 160 mm x 220 mm; insert plate, outside diameter 110 mm. Substage provided; provision for attaching the mechanical stage IMT2-MVR.                                                                 |                         |
|                     | Mechanical stage attachment IMT2-MVR                                                                                                                                                                                                                                                                   | Traversing area 110 mm x 72 mm; attachable at the right or left side on the plain stage.<br>Provision for accommodation of various culture vessels and specimen holders.                          |                         |
| Illumination:       | Light source                                                                                                                                                                                                                                                                                           | Halogen bulb 12V50W/HAL, with bulb centering device and light intensive control; Voltage indication by bar graph voltmeter.                                                                       |                         |
|                     | Filter holder                                                                                                                                                                                                                                                                                          | Provided with 4 flip-up filter holders; green interference filter and frosted filter.                                                                                                             |                         |
|                     | Condenser holder                                                                                                                                                                                                                                                                                       | Flip-up, swing-out type; circular mounting dovetail for slide-in condenser; vertical movement on rack-and-pinion, condenser centering knobs; tension adjustment of the height adjustment knob.    |                         |
| Observation system: | Built-in magnification changer, with centering telescope 1X-1.5X-CT.                                                                                                                                                                                                                                   |                                                                                                                                                                                                   |                         |
|                     | Light path for photomicrography, 3-setting positions, linked with focusing reticles; for observation tube (BI), 35 mm camera (OM) and multi-tube mounting port (MTU).                                                                                                                                  |                                                                                                                                                                                                   |                         |
|                     | Binocular tube, inclined $45^\circ$ ; interpupillary distance adjustment from 53 mm to 75 mm; constant tube length adjustment.<br>Eyepieces WHK10X, WHK10X-H (field number 20)                                                                                                                         |                                                                                                                                                                                                   |                         |
|                     | OM light path: 2.5X FK photo eyepiece built-in; OM system bayonet mount.                                                                                                                                                                                                                               |                                                                                                                                                                                                   |                         |
|                     | Multi-tube light path; provision for mounting the PM-10 photomicrographic equipment directly as well as the multi-tube attachment.                                                                                                                                                                     |                                                                                                                                                                                                   |                         |
| Condenser:          | Long working distance turret condenser; N.A. 0.55, W.D. 21 mm, light annuli for 4X, 10X, 20X and 40X objectives and empty aperture; aperture iris diaphragm.                                                                                                                                           |                                                                                                                                                                                                   |                         |
|                     | Ultra long working distance condenser; N.A. 0.30, W.D. 55 mm; Light annuli for 4X, 10X, 20X, and 40X objectives plus empty aperture; aperture iris diaphragm.                                                                                                                                          |                                                                                                                                                                                                   |                         |
| Objectives:         | Phase contrast objectives                                                                                                                                                                                                                                                                              | PC S Plan 4XPL                                                                                                                                                                                    | N.A. 0.13, W.D. 15.5 mm |
|                     |                                                                                                                                                                                                                                                                                                        | PC S Plan 10XPL                                                                                                                                                                                   | N.A. 0.30, W.D. 7.5 mm  |
|                     |                                                                                                                                                                                                                                                                                                        | LWD-CD Plan 20XPL                                                                                                                                                                                 | N.A. 0.40, W.D. 3.0 mm  |
|                     |                                                                                                                                                                                                                                                                                                        | LWD-CD Plan 40XPL                                                                                                                                                                                 | N.A. 0.60, W.D. 1.9 mm  |
|                     |                                                                                                                                                                                                                                                                                                        |                                                                                                                                                                                                   | with correction collar  |
|                     |                                                                                                                                                                                                                                                                                                        |                                                                                                                                                                                                   | with correction collar  |
| Dimensions:         | 320 mm (W) x 395 mm (D) x 600 mm (H)                                                                                                                                                                                                                                                                   | Eyepoint 405 mm                                                                                                                                                                                   | Stage height 275 mm     |
| Weight:             | 20.5 kg (outfitted with standard equipment)                                                                                                                                                                                                                                                            |                                                                                                                                                                                                   |                         |

# 2

## STANDARD CONFIGURATIONS

| Component                                                                                                                                                                                                         | Model        | IMT-2-11 | IMT-2-12 | IMT-2-21 | IMT-2-31 |
|-------------------------------------------------------------------------------------------------------------------------------------------------------------------------------------------------------------------|--------------|----------|----------|----------|----------|
| Microscope stand, with built-in magnification changer (1X-1.5X-CT), built-in 2.5X photo eyepiece, 50W halogen illuminator, condenser holder, hand rests (paired), dust cover, filter 43IF550-W45 and screw driver | IMT2-F       | ○        | ○        | ○        | ○        |
| Power cord                                                                                                                                                                                                        | UYCP         | ○        | ○        | ○        | ○        |
| Binocular tube, 45° inclined                                                                                                                                                                                      | BH2-BI45     | ○        | ○        | ○        | ○        |
| Intermediate tube                                                                                                                                                                                                 | IMT2-ATU     | ○        | ○        | ○        | ○        |
| Sextuple revolving nosepiece                                                                                                                                                                                      | IMT2-RE      | ○        | ○        | ○        | ○        |
| 50W halogen lamp housing                                                                                                                                                                                          | IMT2-LSH     | ○        | ○        | ○        | ○        |
| 50W halogen bulbs, 2 pcs.                                                                                                                                                                                         | JC12V50WHAL  | ○        | ○        | ○        | ○        |
| Cross-movement mechanical stage with right-hand low drive controls                                                                                                                                                | IMT2-SVR     |          |          |          | ○        |
| Cross-movement mechanical stage with right-hand low flexible                                                                                                                                                      | IMT2-SFR     |          |          |          | ○        |
| Square plain stage                                                                                                                                                                                                | IMT2-SP2     | ○        | ○        |          |          |
| Mechanical stage attachment with low drive controls                                                                                                                                                               | IMT2-MVR     | ○        | ○        |          |          |
| Long working distance turret condenser                                                                                                                                                                            | IMT2-LWCD    |          | ○        | ○        | ○        |
| Ultra long working distance turret condenser                                                                                                                                                                      | IMT2-ULWCD   | ○        | ○        | ○        | ○        |
| Objectives                                                                                                                                                                                                        | PCSPL4XPL    |          | ○        | ○        | ○        |
|                                                                                                                                                                                                                   | PCSPL10XPL   | ○        | ○        | ○        | ○        |
|                                                                                                                                                                                                                   | LWDCDPL20XPL | ○        | ○        | ○        | ○        |
|                                                                                                                                                                                                                   | LWDCDPL40XPL |          | ○        | ○        | ○        |
| Eyepieces                                                                                                                                                                                                         | WHK10X       | ○        | ○        | ○        | ○        |
|                                                                                                                                                                                                                   | WHK10X-H     | ○        | ○        | ○        | ○        |

Note: ○ indicates the compatible components for Model IMT-2-11/IMT-2-12/IMT-2-21/IMT-2-31.

# 3 NOMENCLATURE

NOMENCLATURE 3

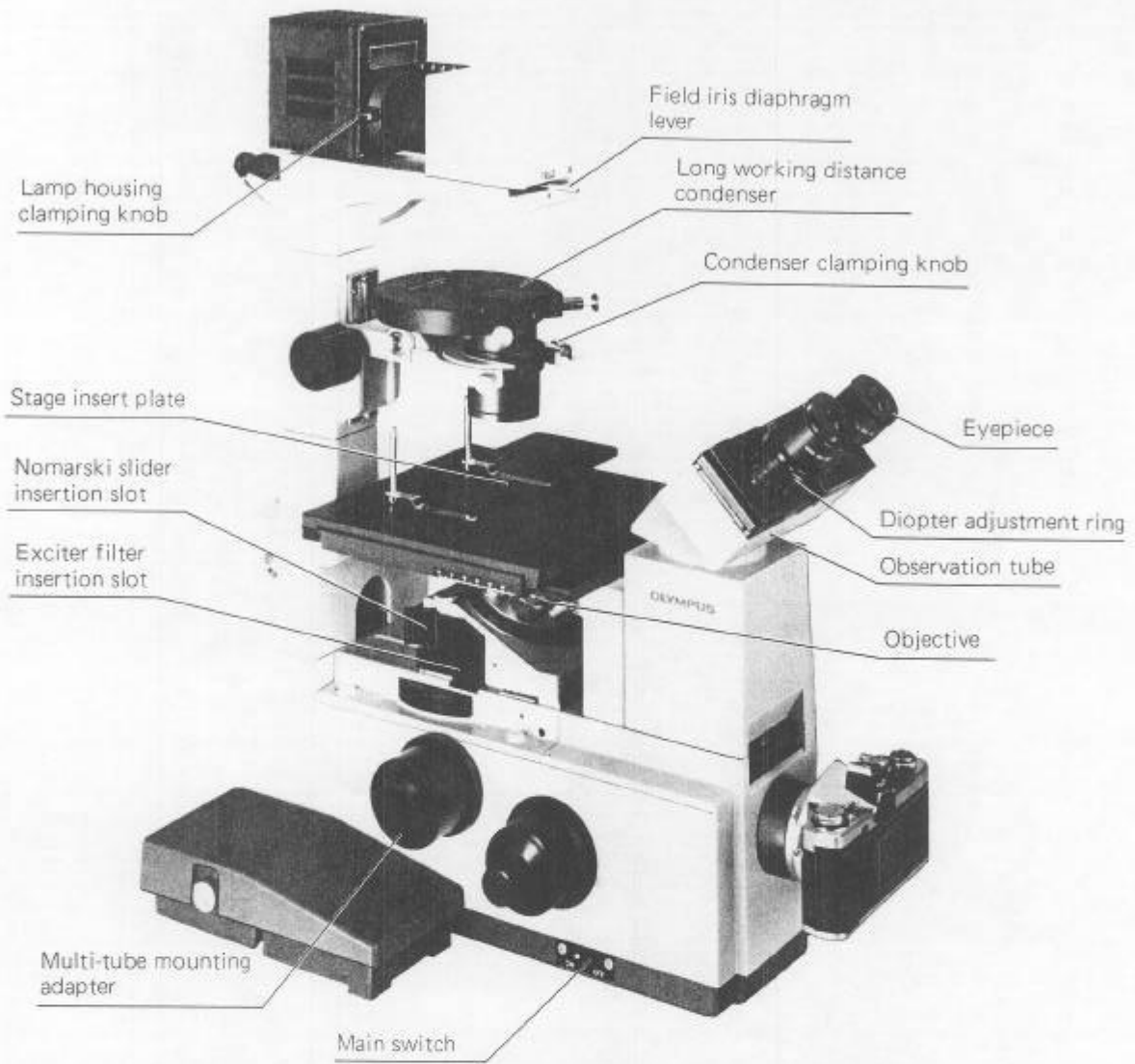

(IMT-2-12 shown)

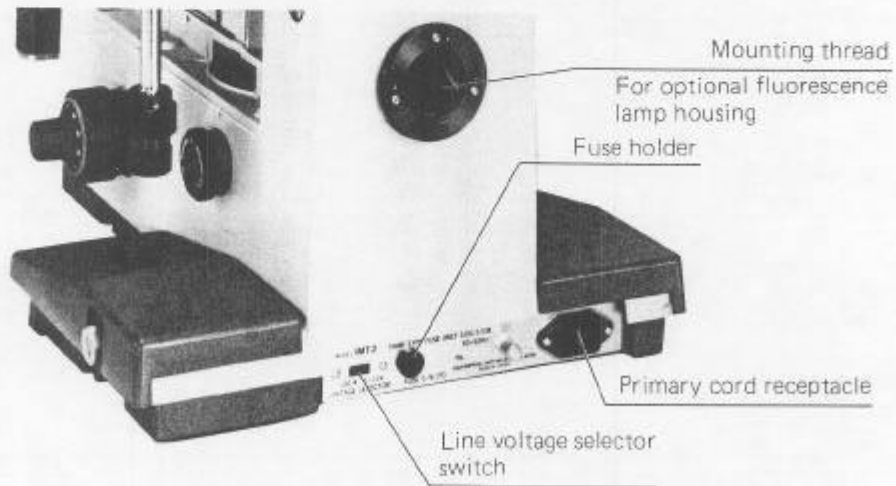

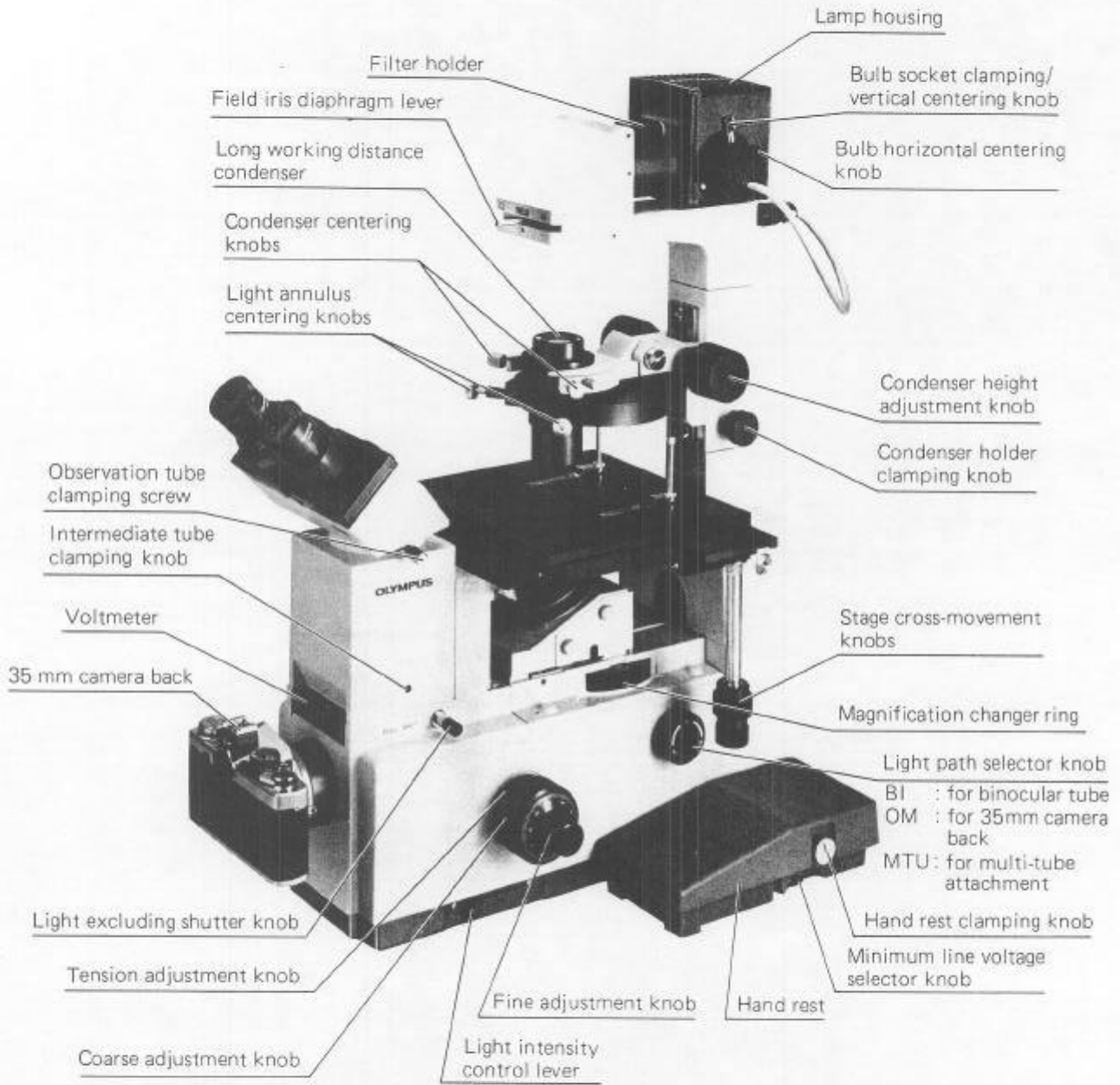

(IMT-2-12 shown)

# 4 ASSEMBLY

Remove the adhesive tape that locks the light path selector knob in transit. The diagram below illustrates the sequential procedure of assembly. The numbers indicate the assembly order of various components.

★ Remove dust caps before mounting components.

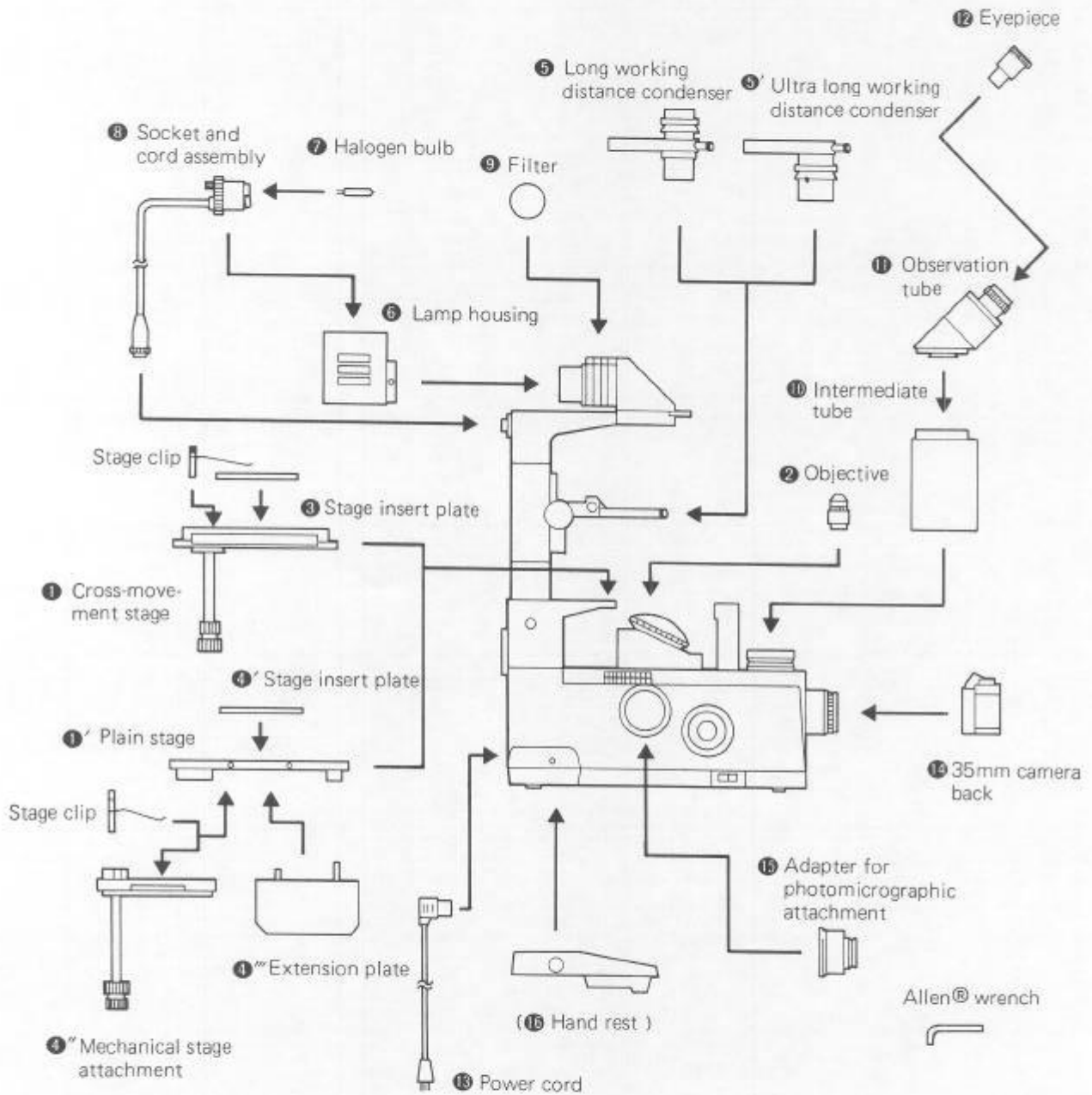



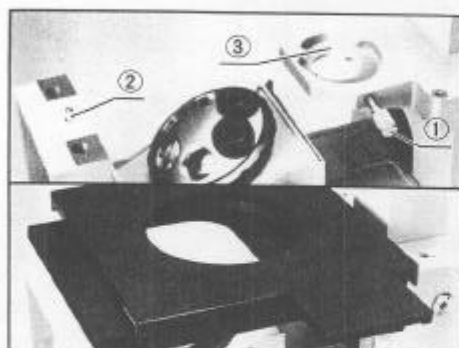

Fig. 2

### 1 Mounting the Stage

- 1) Loosen the clamping screw ①. (Fig. 2)
- 2) Aligning the stage positioning groove to the positioning pin ②, place the circular mounting dovetail of the stage on the stage holder ③. (Fig. 2)
- 3) As the stage clamping screw is tightened, both ends of the stage will be fastened tightly to the microscope stand.

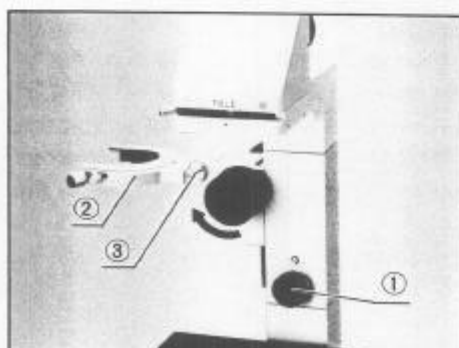

Fig. 3

### 2 Mounting the Objectives

- 1) Loosen the condenser holder clamping knob ①, and flip up the condenser holder ②. (Fig. 3)
  - ★ The tension of the condenser holder tilting motion can be adjusted by means of the clamping screw ③ which can be rotated with a coin.
- 2) Screw each objective ② into the nosepiece ③ through the stage insert mounting hole ① in the stage, lower power to higher power, in a clockwise direction. (Fig. 4)
- 3) Click the condenser holder back to the original position, and clamp with clamping knob.
  - ★ Please note that the front lens of the objective in the inverted microscope faces upward, and is exposed to contamination more than the objective of an upright microscope. Therefore, if there are empty openings in the nosepiece, use the dust plugs ④ provided to prevent dust or debris from falling into the prisms, etc.

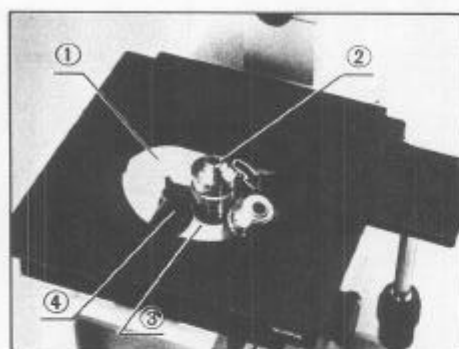

Fig. 4

### 3 Mounting the Cross-movement Stage

#### 1) Stage insert plate

Place a stage insert plate ① on the stage. (The insert plates are provided with inner diameters 20mm and 50mm. It is recommended to select a stage insert plate with an inner diameter slightly smaller than that of a culture vessel in order to prevent the vessel from toppling down.) (Fig. 5)

- ★ The insert plate is designed to be very thin so as to avoid hitting against the objectives at objective magnification change.
- ★ Do not handle the insert plate roughly since this may deform.

#### 2) Stage clip

Attach a pair of stage clips provided with clamping screws ② on the stage.

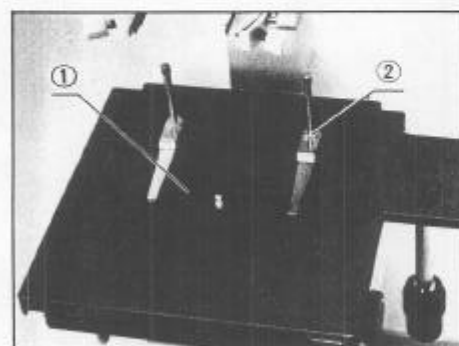

Fig. 5

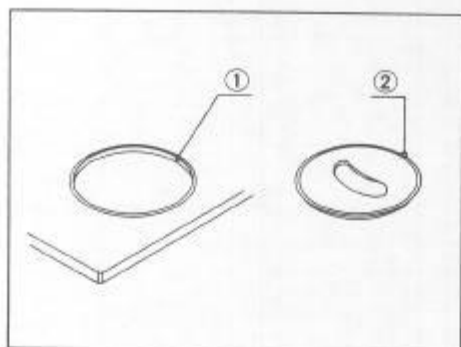

Fig. 6

#### 4 Attaching the Plain Stage

##### 1) Insert plate (IMT2-SP2)

Aligning the guide pin ② of the insert plate with the notch ① in the stage, mount the insert plate. (Fig. 6)

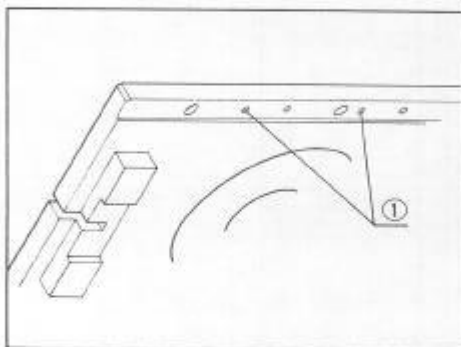

Fig. 7

##### 2) Mechanical stage attachment (IMT2-MVR)

Attach the mechanical stage attachment to the lower right side of the plain stage, tightening the clamping screw ① with a coin. (Fig. 7)

★ If no photographic equipment, such as the PM-10AD equipment, etc. is attached to the "MTU" light exit port of the microscope base, the stage attachment can be attached on the left side of the plain stage.

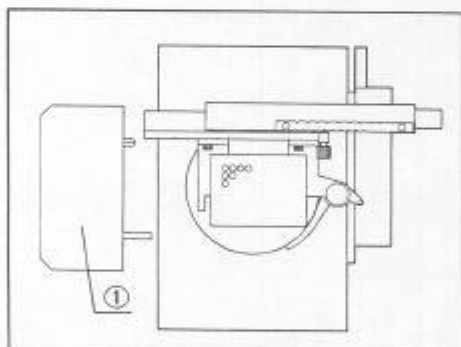

Fig. 8

##### 3) Stage extension plate

Align the guide pins of the extension plate ① into the positioning holes in the plain stage, and attach securely. (Fig. 8)

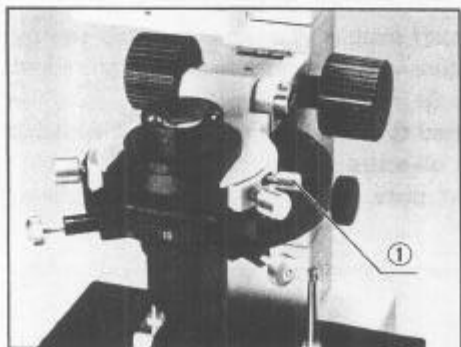

Fig. 9

#### 5 Attaching the Condenser

Insert the circular dovetail of the condenser into the condenser holder, and clamp with knob ①. (Fig. 9)

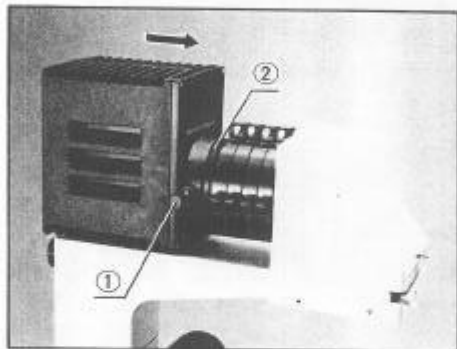

Fig. 10

**6 Attaching the Lamp Housing (IMT2-LSH)**

Loosen clamping knob ① of the lamp housing and connect the lamp housing to the collector lens sleeve ②, and clamp. (Fig. 10)

★ The precise focusing position of the lamp housing varies depending upon the condensers. (See pages 14, 15, 16)

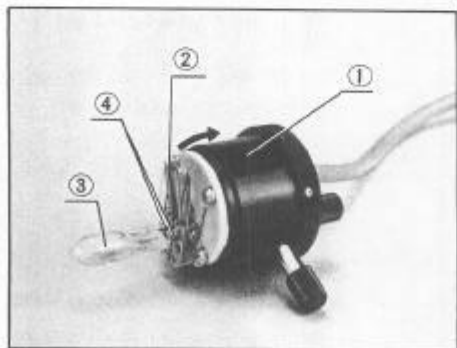

Fig. 11

**7 Mounting the Halogen Bulb**

1) Press the spring levers ② of the bulb socket ① in the direction of the arrow, and insert the bulb pins ③ into the socket holes ④. (Fig. 11)

★ Use gloves or gauze to hold the bulb.

2) Release the levers and the bulb is held in position.

★ Do not touch the bulb portion with bare hands. If fingerprints or dust are left on the bulb, wipe them off; otherwise the bulb life will be considerably reduced.

★ Use a standard bulb as designated by Olympus (12V50WHAL). If a 12V 100W halogen bulb or other high power bulb is used, the power circuit may be damaged.

Bulb to use:

|            |                                                                                  |
|------------|----------------------------------------------------------------------------------|
| Standard   | 12V50WHAL: High intensity type; effective life at rated conditions about 50 hrs. |
| Compatible | 12V50WHAL-L: Long life type; effective life at rated conditions about 2,000 hrs. |

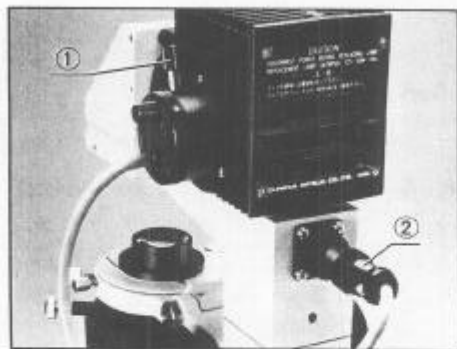

Fig. 12

**8 Connecting the Bulb Socket and Cord Assembly**

Insert the socket into the lamp housing and clamp with knob ①. (Fig. 12)

Connect the cord plug ② to the receptacle at the back of the microscope stand.

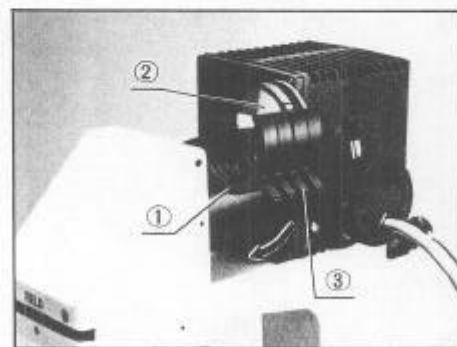

Fig. 13

**9 Mounting the Filters**

1) Press the lever ③ all the way down and insert a filter ② into the filter holder ①.

★ Hold the filter at its circumference to avoid leaving fingerprints or other smudges on the filter surface. (Fig. 13)

2) Mount the frosted filter into the innermost filter holder, with the frosted surface facing the operator. Mount the green filter into the adjacent holder. The other 2 filter holders are provided to accommodate additional filters, optionally available, e.g. 43ND6-W45, 45-LBD-2N.

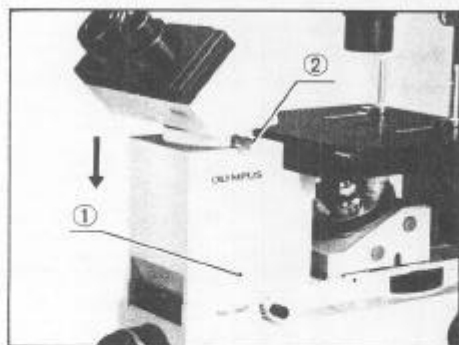

Fig. 14

#### ⑩ Connecting the Intermediate Tube (IMT2-ATU)

Place the intermediate tube on the microscope base, and clamp screw ① with Allen wrench provided. (Fig. 14)

#### ⑪ Mounting the Observation Tube

Loosen the clamping knob ② fully; insert the circular dovetail of the observation tube into the intermediate tube, and clamp. (Fig. 14)

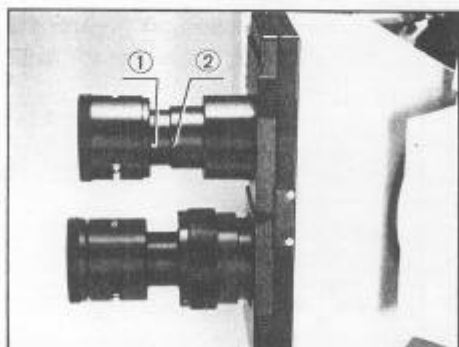

Fig. 15

#### ⑫ Inserting the Eyepieces

Insert the eyepiece WHK10X-H (focusable with helicoid) into the right eyepiece sleeve of the binocular tube, aligning the locating pin ① to the locating groove ②. (Fig. 15)

Insert the eyepiece WHK10X (without helicoid) into the left sleeve.

#### ⑬ Connecting the Primary Cord to the Receptacle at the Microscope Base

Make sure the power switch is turned off; then connect the primary cord to the AC outlet.

★ Ground the microscope to a properly grounded device (except a gas pipe). If necessary, use an extension cord.

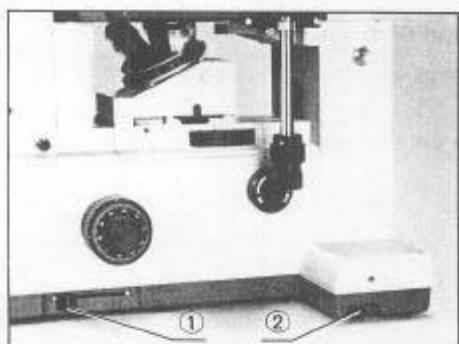

Fig. 16

#### ⑭ Attaching the 35 mm Camera Back

#### ⑮ Attaching the Photomicrographic Adapter to the "MTU" Light Exit Port

##### ■ Minimum line voltage adjustment

1) The minimum voltage required for the light source can be controlled by means of the line voltage adjustment dial ② provided on the microscope base (at the right-hand side). (Fig. 16)

2) Ascertain that the sliding control lever ① is positioned closest to you (low voltage), and then activate the main switch.

3) Rotate the line voltage adjustment dial ② until the lamp is dimly lit.

★ The minimum voltage adjustment does not affect the maximum intensity of the bulb.

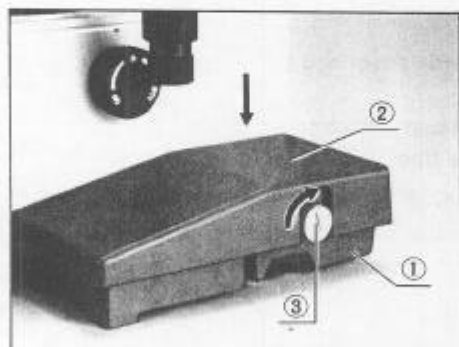

Fig. 17

#### ⑯ Attaching the Hand Rests

Attach the hand rests ② on the right and left sides ① of the microscope base, clamp knobs 3 with a coin. (Fig. 17)

★ Do not grasp the hand rests to carry the microscope.

★ When the color temperature regulator of the PM-10 system is attached to the microscope base, or other attachments are juxtaposed closely to the microscope, the hand rests can be detached in case they interfere with the operation of these attachments.

# 5 OPERATION

## 5-1 Observation Procedure

| Normal procedure                   | Adjustment necessary for operation                                                                             | Relevant part                            | (page)        |
|------------------------------------|----------------------------------------------------------------------------------------------------------------|------------------------------------------|---------------|
| <b>Preparation</b>                 |                                                                                                                |                                          |               |
|                                    | Swing out the filters.<br>Lower the nosepiece.                                                                 | Filter holders<br>Coarse adjustment knob | ( 8 )<br>(14) |
| Switch on the light source.        |                                                                                                                | Main switch                              | (11)          |
|                                    | Rotate the light path selector knob to "BI".                                                                   | Light path selector knob                 | ( 4 )         |
| Place a specimen on stage.         |                                                                                                                | Specimen holder                          | (12)          |
| Swing in the 10X objective.        |                                                                                                                |                                          |               |
|                                    | Rotate the condenser turret to "O" position. Stop down the aperture iris diaphragm for low contrast specimens. | Aperture iris diaphragm in condenser     | (14)          |
| Interpupillary distance adjustment |                                                                                                                | Eyepiece sliding dovetails               | (12)          |
| Diopter adjustment                 |                                                                                                                | Diopter adjustment ring                  | (14)          |
| Focus                              |                                                                                                                | Coarse and fine adjustment knobs         | (14)          |
|                                    | Focus on the field iris diaphragm                                                                              | Condenser height adjustment knob         | (14)          |
|                                    | Condenser height adjustment                                                                                    | Condenser centering knob                 | (14)          |
|                                    | Condenser centration (with magnification changer at CT position); bulb centration                              | Bulb centering knob<br>CT focusing ring  | (14)<br>(14)  |
| Engage the desired objective.      |                                                                                                                |                                          |               |
| Match the condenser turret.        |                                                                                                                | Condenser turret                         | (14)          |
|                                    | Light annulus centration                                                                                       | Light annulus centering knob<br>CT       | (15)<br>(15)  |
| Fine focus                         |                                                                                                                | Coarse and fine adjustment knobs         | (14)          |
|                                    | Adjust the correction collar of objectives 20X and 40X according to the thickness of the vessel bottom.        | Correction collar                        | (16)          |
| Adjust light intensity.            |                                                                                                                | Sliding voltage control lever            | (11)          |
|                                    | Adjust the aperture iris diaphragm in brightfield.                                                             | Aperture iris diaphragm                  | (14)          |
| <b>Observation</b>                 |                                                                                                                |                                          |               |

5 OPERATION

## 5-2 Operation of Individual Components

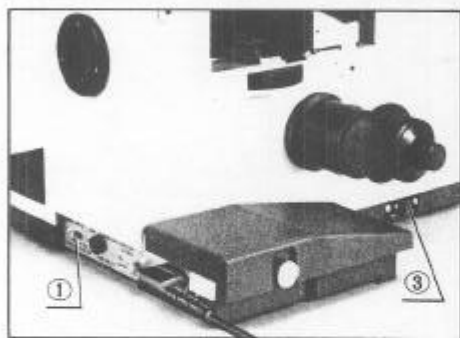

Fig. 18

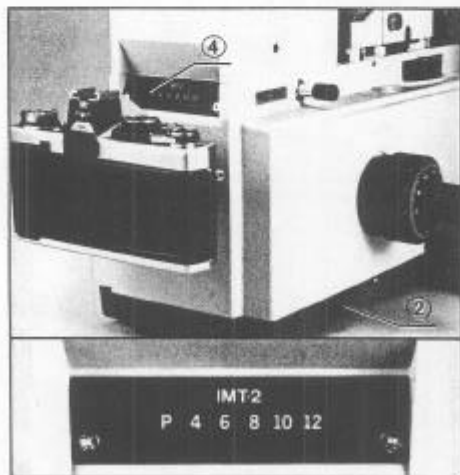

Fig. 19

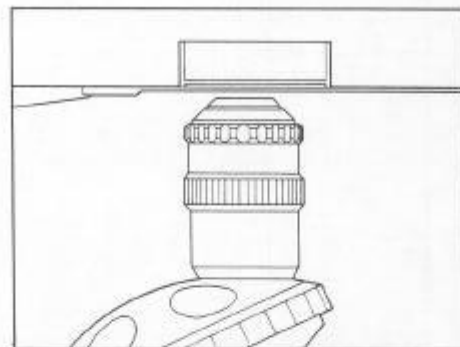

Fig. 20

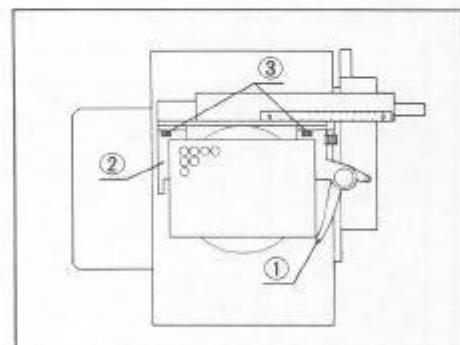

Fig. 21

### ① Switching on the Light Source

- 1) Ascertain that the line voltage selector switch ① located at the back of the microscope stand is set to conform with the local mains voltage. (Fig. 18) If not, adjust correctly by means of a small screwdriver.

- 2) Make sure that the sliding voltage control lever ② is set at the closest position to the operator (low voltage), then turn on the power switch ③. (Figs. 18 & 19)

### Voltage adjustment and light intensity

- As you push the control lever forward, the LED at the indicator "P" lights up on the left side of the voltmeter ④ to indicate the bulb voltage between 0 ~ 3V. Then, five LED on the right side indicate 4V ~ 12V in increments of 2V. (Fig. 19)
- For overvoltage beyond 12V (at local mains 115V), the extremely right-hand LED blinks for warning.
  - ★ The effective life of a bulb will be prolonged if it is used at a voltage lower than rated.
  - ★ For use of daylight type color film, use the LBD-2N filter with voltage at about 8V.

### ② Place a Specimen on the Stage.

#### A. Cross-movement stage (IMT2-SVR, IMT2-SFR)

- 1) The traversing area of the cross-movement stage is 50 mm x 50 mm. Select the insert plate with an inner diameter of 20 mm or 50 mm according to the specimen, vessel, and observation area.
- 2) Place a specimen on the stage.

- ★ If you rotate the nosepiece or move the cross-movement stage after focusing on the specimen in a vessel, the lower surface of which is positioned more than 1 mm above the stage surface, the front lens of the objective may sometimes hit against the insert plate from underneath. (Fig. 20) Therefore, it is necessary to ascertain its safety before rotating the nosepiece. If there is any possibility to impinge, it is safe to lower and then rotate the nosepiece.

#### B. Plain stage (IMT2-SP2) and mechanical stage attachment (IMT2-MVR)

- 1) Placement of various vessels or glass slides  
Coincide the vessel center with the center of the X scale (55 mm position) by adjusting the position of the specimen holder ①, ②, then clamp in position with knobs ③. (Fig. 21)  
(See p. 13 for setup of stage attachments in detail.)

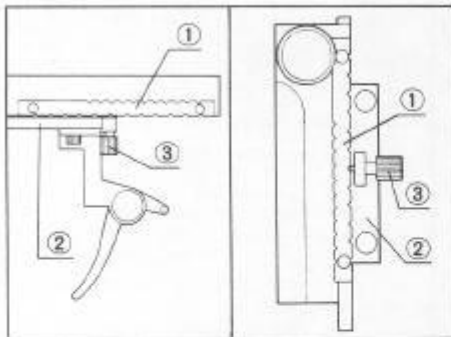

Fig. 22

2) Click-stop plate

This mechanical stage attachment permits the use of the click-stop plates for 96-well micro titre plates and the 24-well micro titre plate of other chambers in any click position for each well, as desired. Install the click-stop plate ①. (Fig. 22)

Attach the click ②, and screw the click spring tube ③ in a manner it clicks the stage.

Moving the stage, adjust the click position so that it clicks at the center of each well.

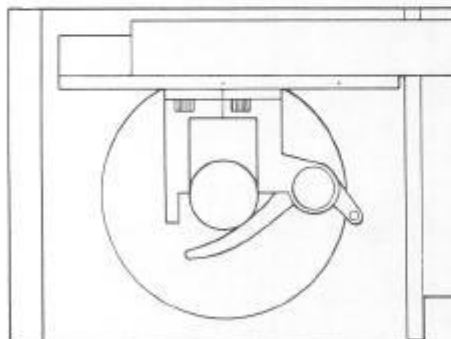

Fig. 23

3) Specimen holder

Opening the spring-loaded finger of the specimen holder with one hand, place a specimen slide inside the holder with the other hand. (Fig. 23)

- ★ When the slide comes in contact with the back of the specimen holder, slowly return the spring-loaded finger.
- ★ If the spring-loaded finger is returned too quickly, it may cause damage to the specimen slide, or spill the culture solution.
- ★ If the bottom of the vessel is rounded off or shaped similarly, the spring-loaded finger may sometimes not catch the vessel bottom.

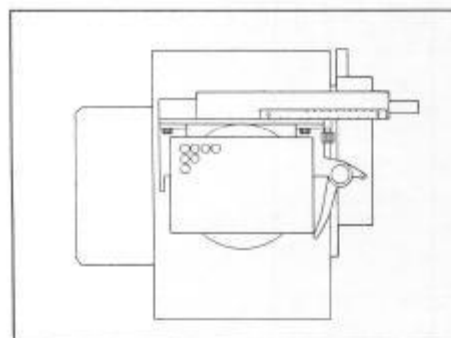

Fig. 24

4) Stage extension plate

The plain stage is reduced in its width to match the compact mechanical stage attachment. To observe a large culture vessel, connect the extension plate to the side of the plain stage. (Fig. 24)

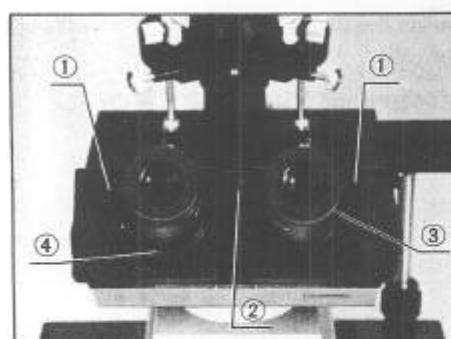

Fig. 25

⑥ Observation Tube

- 1) Looking through the binocular tube, slide the knurled dovetail mounts ① of the right and left eyepieces with both hands, until a perfect binocular vision is obtained. (Fig. 25)
- 2) If your interpupillary distance setting is already known, set it on the scale ② located between the eyepieces.

3) Diopter adjustment

- a. Rotate the light path selector knob to the "OM" position.
- b. Looking through the focusable eyepiece with the right eye, rotate the helicoid ring ③ on the eyepiece, until the frame reticle can be sharply focused. (Fig. 25)

Then, looking through the left eyepiece with the left eye, rotate the diopter ring ④ until the cross lines can be sharply recognized as two separate lines. (Fig. 26)



Fig. 26

Setup of the mechanical stage attachment IMT2-MVR in detail

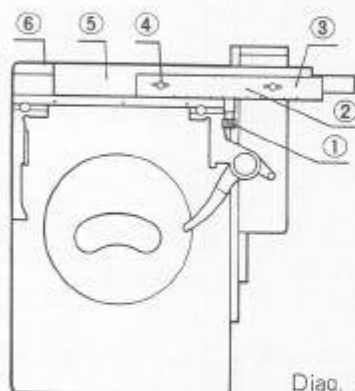

Diag. 1

① Attaching the click-stop plate to the mechanical stage IMT2-MVR

- 1) Loosen the click-stop knob ①. (Diag. 1)
- 2) Align the click-stop notches ② with the click-stop knob.  
Pitch: 6.35 mm for 60-well Terasaki plate  
9 mm for 96-well microtiter plate

★ The click-stop plate should be oriented with the longer marginal portion ③ (between the plate end and groove) at the operator's right-hand side (in the X direction) or closest to the operator (in the Y direction). (Diag. 1)

- 3) Slightly tighten the click-stop plate clamping knob ④ with care that the click-stop plate can be moved slightly until the click-stop knob ① fits into the notch. (Diag. 1)

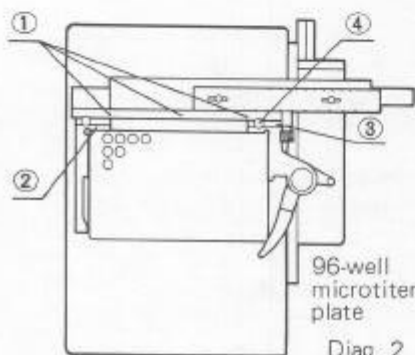

Diag. 2

② Mounting the mechanical stage on the plain stage IMT2-SP

- 1) Rotate the Y-axis drive control knob clockwise all the way.
- 2) Place the mechanical stage on the plain stage in a manner that the back ⑤ of the mechanical stage is flush with that ⑥ of the plain stage. (Diag. 1)
- 3) Tighten two clamping knobs at the underside of the mechanical stage to the lower right side of the plain stage with a coin.

③ Use of various specimen vessels

- 1) Place a specimen vessel on the stage as shown in Diag. 2 through 6.

★ For use of a 96-well microtiter plate or 60-well Terasaki plate, align the right- and left-hand sliders ② & ③ with the index marks ① on the X axis graduations as shown in Diag. 2, and clamp each slider clamping knob ④.

④ Centration of the click-stop plate (96-well microtiter plate and 60-well Terasaki plate)

- 1) Looking through the microscope eyepieces, rotate the low drive control knobs until the center of the well to be observed coincides with the center of the field of view.
- 2) Tighten the clamping knob ④ of the click-stop plate. (Diag. 1)

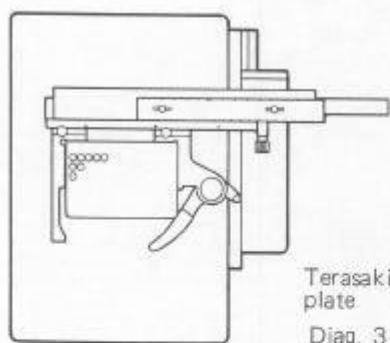

Terasaki plate  
Diag. 3

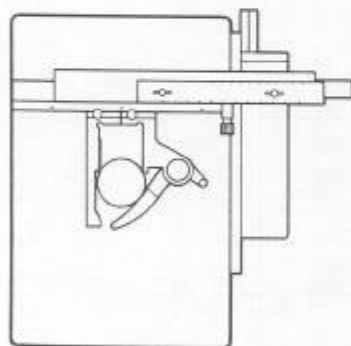

30mm-35mm dia. Petri dish  
Diag. 4

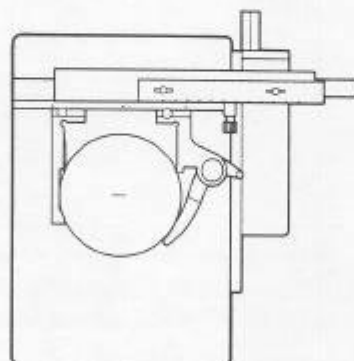

60mm-90mm dia. Petri dish  
Diag. 5

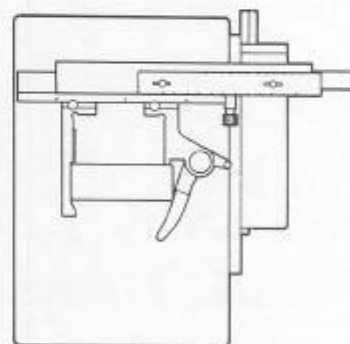

Slide glass  
Diag. 6



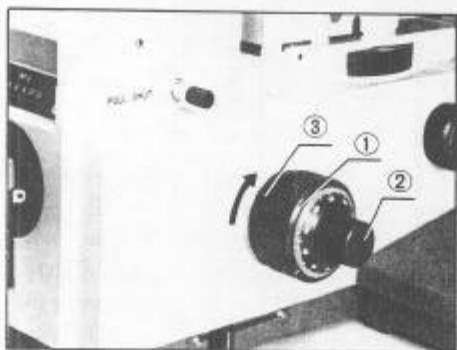

Fig. 27

#### 4 Coarse and Fine Adjustment Knobs

- 1) Bring the objective as close as possible to the specimen without touching and focus on the specimen roughly by means of the coarse adjustment knobs ①, then fine focus with the fine adjustment knobs ②. (Fig. 27)

##### Tension adjustment of coarse adjustment knobs

While the coarse adjustment motion is normally stiff and heavy, it is freely adjustable for either heavy or light movement depending on the observer's preference. To adjust the tension, rotate the tension adjustment ring ③ in the direction of the arrow to tighten the coarse adjustment knobs. (Fig. 27)

- ★ The fine adjustment motion is not adjustable.
- ★ Be careful not to forcibly rotate the coarse or fine adjustment knobs against the upper or lower limit of the focusing range.
- ★ Do not rotate the coarse and fine adjustment knobs simultaneously to avoid any damage to focusing adjustments.

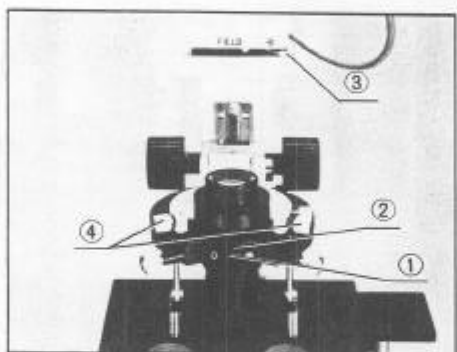

Fig. 28

#### 5 Condenser Centration

The centering operations of the long working distance condenser and the ultra long working distance condenser are the same as follows:

- 1) Set the turret ① to the "○ ⊗" position. (Fig. 28)
- 2) Bring the specimen into focus by means of the 10X objective.
  - ★ It is recommended to stop down the aperture iris diaphragm ② for easier focusing on an unstained specimen. (Fig. 28)
- 3) Stop down the field iris diaphragm by means of the field iris diaphragm lever ③ and adjust the condenser height until the image of the field diaphragm can be observed sharply. (Figs. 28, 29)
  - ★ Holding the right condenser knob with the right hand, rotate the left condenser knob until the tension of the condenser height adjustment knobs is adjusted to your preference.
- 4) Bring the image of the field diaphragm into the center of the field by means of the condenser centering knobs ④. (Figs. 28, 29) Re-open the diaphragm until the small pinhole image of the diaphragm becomes a larger polygonal area around the periphery of the field. For practical use, slightly open the diaphragm to circumscribe the field of view.

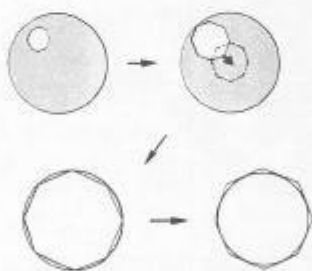

Fig. 29

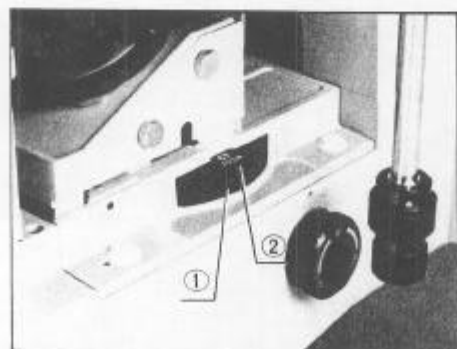

Fig. 30

#### 6 Bulb Centration

After the complete optical setup, center the halogen bulb.

- 1) Rotate the magnification changer dial ① to position "CT". (Fig. 30)
- 2) Rotate the focus ring ② to focus on the exit pupil of the 10X objective (located at the same plane as the phase annulus of the phase objective, the light annulus of the phase contrast condenser or the aperture iris diaphragm). (Fig. 30)

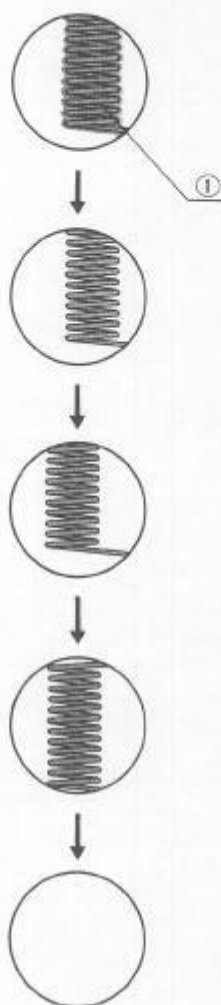

Fig. 31

- 3) Flip up the frosted filter so that the image of the bulb filament ① can be observed. (Fig. 31)
- 4) Loosening the lamp housing clamping knob, move the lamp housing in the axial direction until the filament image is brought into focus.

- ★ Repeat this adjustment whenever the long working and ultra long working distance condensers are interchanged.
- ★ If it is necessary to increase the light intensity with the phase objective 40X, move the lamp housing so that the filament image completely fills the image of the light annulus. If you change the objective 40X to 4X, at this stage, you will note that the light intensity will be somewhat reduced at the periphery of the field.

- 5) Center the filament image by means of the bulb centering knobs.
- 6) Re-engage the frosted filter.

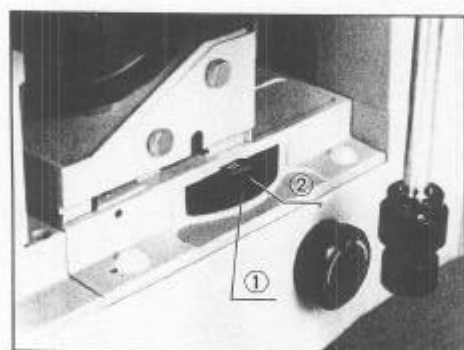

Fig. 32

#### ⑦ Light Annulus Centration

This centering adjustment equally pertains to the long working and ultra long working distance condensers.

- ★ The IMT-2 microscope adopted the individual centration system of each phase annulus, so that strict centration of the light annulus can be achieved with each objective. Therefore, match the light annulus to the phase objective magnification whenever objectives are changed, and re-centration is not necessary once the initial centration has been accomplished.
- ★ Recentration, however, is required when the bottom of a culture vessel is not flat.
- ★ This centration is applied to objectives from low to high magnifications.

- 1) Swing in the desired objective and focus on the specimen.
- 2) Rotate the magnification changer to the CT position. (Fig. 32)

- 3) Focus on the phase annulus ③ by means of the focus ring ②. (Figs. 32, 33)
- 4) Rotate the condenser turret until the magnification of the objective engaged appears in the front.

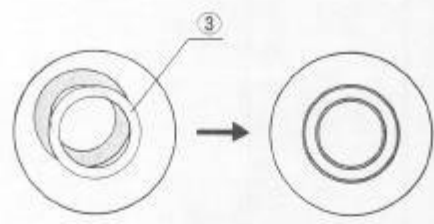

Fig. 33

- 5) Press the light annulus centering knobs ④ and rotate them until both annuli are concentric and superimposed, then slowly disengage the centering knobs ④. (Fig. 34)

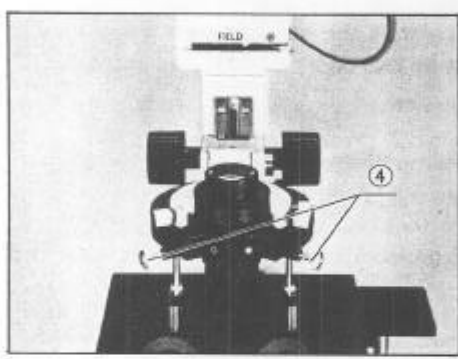

Fig. 34

- 6) Rotate the magnification changer ① to the "1X" position, and observe the specimen to check the phase contrast effect. (Figs. 32, 35)

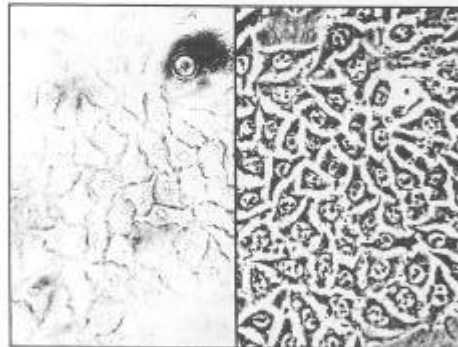

Fig. 35 Phase contrast

**8 Use of the Correction Collar of the Objectives LWD-CD Plan 20X and 40X.**

After coarse and fine adjustments, rotate the correction collar, keeping the specimen in fine focus until optimum resolution is obtained. Proper use of this collar is specially effective to prevent the deterioration of the objective resolution caused by the uneven thickness of various petri dishes, culture bottles, etc. (Fig. 36)

★ The correction collar is effective with a vessel bottom from 0 up to 2mm in thickness.

- 1) If the thickness of the vessel bottom is known:  
Match the correction collar to the thickness of the vessel bottom by the collar scale provided.

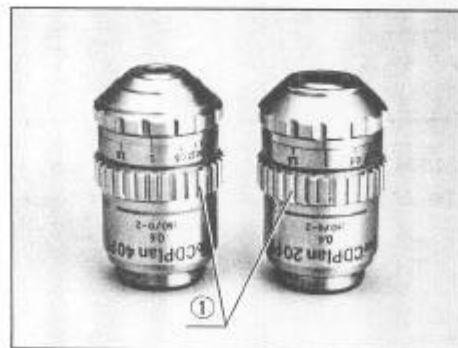

Fig. 36

- 2) If the thickness of the vessel bottom is unknown:

The optimum position for the correction collar can be obtained from the image resolution. After focusing adjustment, if a satisfactory sharp image is not obtained, rotate the correction collar to the right and left so that you can compare the images at both sides. Reset the collar to the better image; then starting from this position, further rotate the collar to the right and left until both images can be obtained for comparison with each other. As you repeat this procedure several times, you have to fine focus each time the correction collar is rotated.

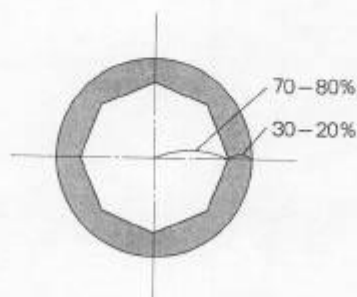

Fig. 37

(As seen through eyepiece tube, with eyepiece removed.)

#### 9 Use of Iris Diaphragms

- 1) Field iris diaphragm

The field iris diaphragm controls the diameter of the ray bundle impinging on the specimen surface and thus increases image definition and reduces glare.

- 2) Aperture iris diaphragm

In order to achieve optimum objective performance in brightfield, the opening of the aperture iris diaphragm should be matched to the N.A. of the objective in use. It is often preferable, however, to stop down the aperture diaphragm by about 70% to 80% of the objective N.A. (Fig. 37)

#### 10 Filters

Optimum use of proper filters enhances the effective observation and photomicrography.

| No. | Filter                 | Designation  | Purpose                                                      |
|-----|------------------------|--------------|--------------------------------------------------------------|
| 1   | Diffusion              | 45WF         | Eliminates uneven illumination.                              |
| 2   | Interference (green)   | 43-IF550-W45 | Enhances phase contrast.                                     |
| 3   | Neutral density (grey) | 43ND25-W45   | Reduces light intensity without changing color temperature.  |
| 4   |                        | 43ND6-W45    |                                                              |
| 5   | Light balancing        | 45-LBD-2N    | For color photomicrography with daylight film.               |
| 6   | *Heat absorbing        | 45-HA        | Absorbs heat waves 760nm and higher to protect the specimen. |

\*This filter is built in the IMT2-LSH. It is recommended to add a heat filter for prolonged observation or time-lapse photography of tissue cultures, etc.

## 6-1 Photomicrographic System

The IMT-2 microscope features provisions for mounting of photomicrographic attachments at 4 places, which can be selected according to preference.

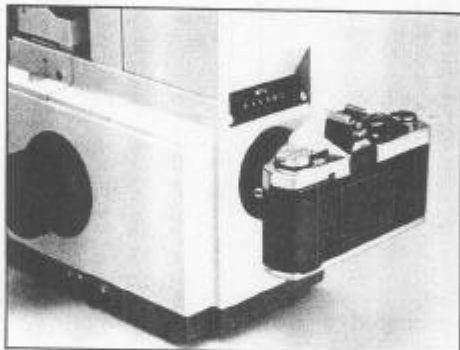

Fig. 38

### A. OM light path (for 35 mm camera back)

1) A 35 mm camera back can be mounted in the same way a camera lens is bayonet-mounted on a camera. (Fig. 38)

- ★ It is not recommended to take pictures of floating specimens in liquid or on a micro-pipette, with objectives 40X or higher, to avoid shutter vibration as much as possible.
- ★ Image magnification = Objective magnif. x 2.5 x Intermediate magnif. (1X or 1.5X)

Ex.  $40 \times 2.5 \times 1.5X = 150(X)$

2) Focus on the specimen, looking through the binocular tube.

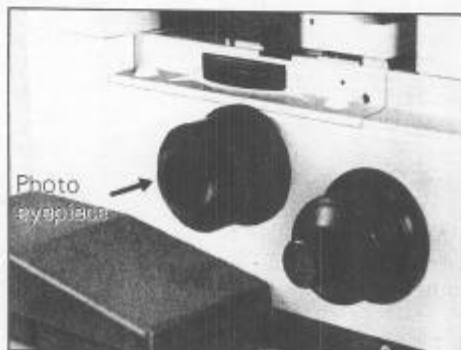

Fig. 39

### B. MTU light path

(for direct mounting of the photomicrographic attachment PM-10AD)

You can take pictures without shutter vibration, since the attachment is designed vibration-proof.

1) The photo eyepieces available include NFK2.5X, 3.3X, 5X and 6.7X.

- ★ Insert the photo eyepiece into the port on the left side of the base. (Fig. 39)
- ★ When you insert the photo eyepiece into the photo tube, you may feel resistance midway because of a spring; make sure to completely insert the eyepiece until it stops.

2) Mount the photomicrographic attachment as indicated in Fig. 40. If the unit is tilted, the image will be also tilted against the focusing reticle in the microscope. To avoid tilting, make it a point to visually parallelize the horizontal contour of the attachment to the horizontal line of the microscope.

3) Image magnification

= Objective magnif. x Intermediate magnif. (1X or 1.5X) x NFK photo eyepiece magnif. x Camera magnif. (1X for 35 mm or 3X for large format)

Ex.  $40 \times 1.5 \times 5 \times 1X = 300(X)$

4) Focusing

Focus the frame reticle first, by rotating the helicoid mount of the left hand eyepiece sleeve of the binocular tube, then focus the specimen by means of the fine focus knob.

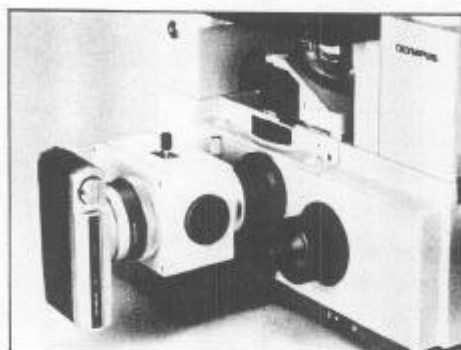

Fig. 40

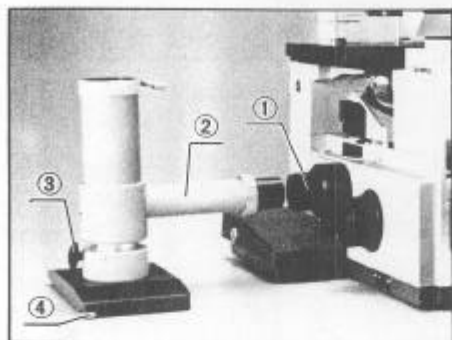

Fig. 41

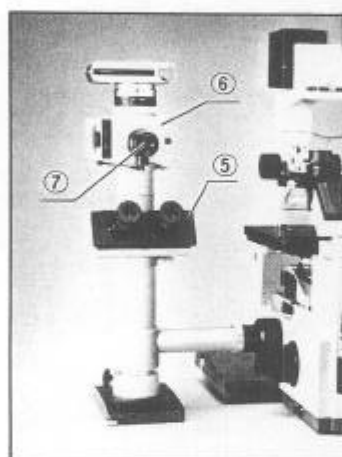

Fig. 42

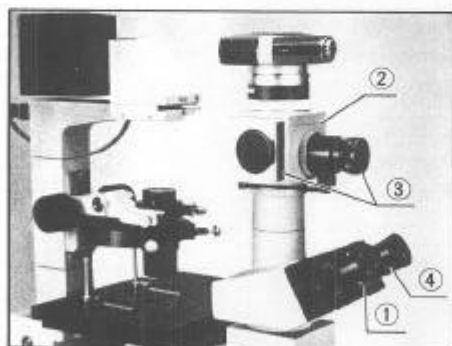

Fig. 43

### C. Mounting the multi-photo tube to the MTU light exit

Mount the multi-photo tube to the MTU light exit port; then clamp the photomicrographic attachment on it. (Fig. 41)

If the PM-10AD system is used in this way, the following options are available:

- Spot exposure measurement (with PM-10ADS)
- Bright frame viewer PM-VSB
- 16 mm cine-photomicrography (PM-16 mm Cine), which enables easy film loading and prevents shutter vibration.

1) Unscrew the photo adapter mounted on the MTU port and replace it with the MTU adapter ①. (Fig. 41)

2) Insert the MTU relay tube ② into the MTU adapter ① and clamp. (Fig. 41)

3) Loosen the base clamping screw ③, and place the base on the desk. (Fig. 41)

4) Rotate the 4 leveling screws ④ to keep them in contact with the desk surface. (Fig. 41)

5) Clamp the base clamping knob ③. (Fig. 41)

6) Attach the trinocular tube ⑤. (Fig. 42)

7) Insert the photo eyepiece into the photo tube.

8) Connect the PM-10AD attachment ⑥. (Fig. 42)

★ When using the multi-tube unit IMT-2-MTU is used, out of focusing or framing may cause, since the optical path length is long.

★ Please be sure to use the focusing magnifier ⑦ built-in the photographic attachment for focusing or framing.

### D. Mounting the trinocular tube on the microscope frame

In place of standard binocular tube, a trinocular tube BH2-TR ① can be attached and used for photomicrography with the PM-10AD system ②. (Fig. 43)

★ In case of fluorescence photomicrography, the bright frame viewer PM-VSB ③ may be used to facilitate focusing. (Fig. 43)

★ Rotate the light path selector knob to the BI position.

★ In order to focus on the specimen looking through the binocular tube, it is necessary to use a suitable finder eyepiece ④. (Fig. 43)

## 6-2 Taking Pictures

Refer to the instructions provided with each photomicrographic equipment for detailed procedure. This paragraph is given to explain the photomicrographic problems pertaining to the IMT-2.

### ① Illumination

Accurate illumination is more important for photomicrography than for observation since flawless pictures cannot be taken without it. In order to avoid uneven illumination, especially with high contrast film, adjust the illumination, following the observation procedure accuracy.

### ② Radiant Heat from the Light Source

Even optimum intensity of illumination light generates considerable radiant heat for observation or photomicrography, especially in case of Nomarski interference contrast. Living specimens are subject to damage due to radiant heat. Therefore;

- Reduce light intensity as much as possible.
- Use additional heat filters.
- For time-lapse photography, synchronize the light source to exposure (synch. mode).

### ③ Filters and Lamp Voltage

Select the filter and bulb voltage according to the film:

| Film                     | Filter       | Voltage   |
|--------------------------|--------------|-----------|
| Daylight type color film | 45-LBD-2N    | 8V        |
| Tungsten type color film | 45-LBT       | 8V        |
| B & W film               | 43-IF550-W45 | 6V and up |

- ★ To match your preference in color rendition, it is recommended to make test exposure for the determination of optimum bulb voltage.

### ④ Focusing

- 1) Looking through the finder eyepiece, adjust the diopter ring so that the double cross lines can be clearly observed as two distinctly separate lines. (Fig. 44)
  - 2) Bring the specimen into focus, rotating the coarse and fine adjustment knobs.
- ★ Since the focusing reticle and the film plane are in precise alignment, the image focused through the focusing magnifier and the image in the film plane are in focus at the same time. Therefore, unless the adjustment just described is perfect, blurred pictures will result.
  - ★ When using the multi-tube unit IMT-2-MTU is used, out of focusing or framing may cause, since the optical path length is long.
  - ★ Please be sure to use the focusing magnifier ⑦ built-in the photographic attachment for focusing or framing.



Fig. 44

## 5 Framing

### A. OM light path

Frame the specimen image into the 35mm frame reticle. (Fig. 45)

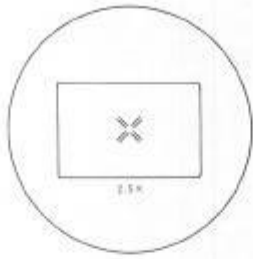

Fig. 45

### B. MTU light path

Frame reticles are matched to NFK photo eyepieces 2.5X, 3.3X and 5X in this order from outer to inner. The outside reticle at each frame indicates 35mm film format and the inside reticle indicates 4" x 3" format.

Picture area on the film plane within the frame.

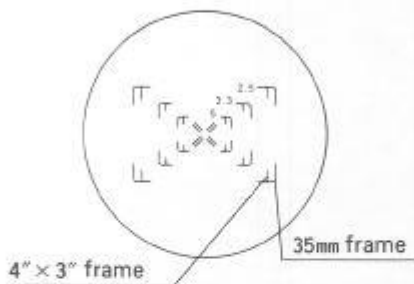

Fig. 46

|              |                   |               |
|--------------|-------------------|---------------|
| Format       | 35 mm             | 4" x 3"       |
| Picture area | 21.5 mm x 32.5 mm | 65 mm x 85 mm |

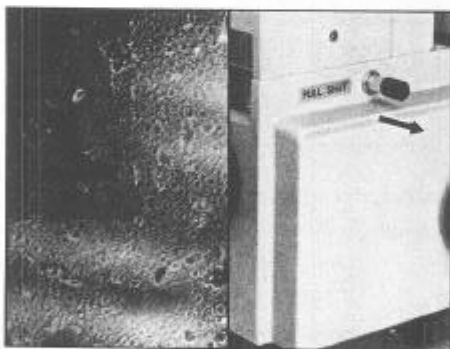

Fig. 47

## 6 Eyepiece Shutter

When you remove your face from the binocular tube while the camera shutter is open for a long time, room light may enter the eyepieces, forming an image coincident on the specimen image to be photographed. To exclude this extraneous light, pull out the eyepiece shutter at the time of exposure. (Fig. 47)



# 7 TROUBLESHOOTING GUIDE

If you are unable to obtain optimum performance from your microscope, please consult the table below for trouble shooting.

| Trouble                                                               | Cause                                                                        | Remedy                                                                           |
|-----------------------------------------------------------------------|------------------------------------------------------------------------------|----------------------------------------------------------------------------------|
| <b>1. Optical system</b>                                              |                                                                              |                                                                                  |
| a) Switching on light source, field of view is still dark.            | Bulb socket cord is not connected.                                           | Connect the cord to receptacle on the microscope stand.                          |
|                                                                       | Bulb is burned out.                                                          | Replace.                                                                         |
|                                                                       | Sliding voltage control lever is set at too low a position.                  | Set it at higher voltage position.                                               |
|                                                                       | Bulb is not centered.                                                        | Center it.                                                                       |
|                                                                       | Condenser holder is not clamped in place.                                    | Clamp it.                                                                        |
|                                                                       | Condenser is not in correct position.                                        | Adjust condenser height until field diaphragm image is formed in specimen plane. |
|                                                                       | Condenser is not centered.                                                   | Center it until field diaphragm image comes in the center.                       |
|                                                                       | Nosepiece is not clicked in place.                                           | Rotate it slightly until it clicks in place.                                     |
|                                                                       | Light path selector knob is at the OM or MTU position.                       | Set knob to the BI position or increase bulb voltage.                            |
|                                                                       | Too many filters are engaged.                                                | Reduce number of filters.                                                        |
|                                                                       | Stage insert plate blocks light path.                                        | Remove stage and reset specimen.                                                 |
|                                                                       | Fuse is burned out.                                                          | Check electric circuit and after removal of cause, replace fuse.                 |
|                                                                       | Line voltage selector switch is not set to conform with local mains voltage. | Adjust switch correctly.                                                         |
| b) Field of view is cut off at the periphery or illuminated unevenly. | Light path selector knob is stopped midway.                                  | Click knob into place according to purpose.                                      |
|                                                                       | Nosepiece and magnification changer are not positioned correctly.            | Click them into place.                                                           |
|                                                                       | Condenser turret is not correctly positioned.                                | Click turret into place.                                                         |
|                                                                       | Condenser is not positioned or centered correctly.                           | Click condenser turret into place or center correctly.                           |
|                                                                       | Light source is not centered.                                                | Center light source.                                                             |
|                                                                       | Filter is stopped midway.                                                    | Pull or push it completely.                                                      |
| c) Dust or dirt is visible in field of view.                          | Dirty specimen.                                                              | Clean slide or culture vessel.                                                   |
|                                                                       | Dust on eyepiece.                                                            | Clean eyepiece.                                                                  |
|                                                                       | Condenser is not correctly positioned and the frosted filter is in focus.    | Adjust condenser height until field diaphragm image is formed on specimen plane. |

| Trouble                                                                                                                                                                        | Cause                                                              | Remedy                                                                                                  |
|--------------------------------------------------------------------------------------------------------------------------------------------------------------------------------|--------------------------------------------------------------------|---------------------------------------------------------------------------------------------------------|
| d) Excessive image contrast.                                                                                                                                                   | Condenser is stopped in high position.                             | Lower condenser.                                                                                        |
|                                                                                                                                                                                | Aperture diaphragm is stopped down excessively.                    | Open diaphragm.                                                                                         |
| e) Resolution problems:<br><ul style="list-style-type: none"> <li>• Image is not sharp.</li> <li>• Insufficient contrast.</li> <li>• Image details lack definition.</li> </ul> | Objective is not correctly positioned in light path.               | Click nosepiece into place.                                                                             |
|                                                                                                                                                                                | Aperture diaphragm is stopped down excessively or opened too much. | Adjust aperture iris opening properly.                                                                  |
|                                                                                                                                                                                | Correction collar is not adjusted correctly.                       | Looking at specimen image, rotate correction collar until optimum focusing position can be found.       |
|                                                                                                                                                                                | Dust on condenser, objective, eyepiece, culture vessel, etc.       | Clean.                                                                                                  |
|                                                                                                                                                                                | Thickness of vessel bottom is more than 2 mm.                      | Use a vessel of bottom thickness less than 2 mm.                                                        |
| f) No effective phase contrast is obtained.                                                                                                                                    | Bright field objective is used.                                    | Use phase objective.                                                                                    |
|                                                                                                                                                                                | Light annulus is not matched with objective.                       | Match light annulus to objective.                                                                       |
|                                                                                                                                                                                | Light annulus and phase annulus are not centered.                  | Center them correctly.                                                                                  |
| g) Specimen image is partially out of focus.                                                                                                                                   | Objective is not correctly in light path.                          | Slightly rotate nosepiece until it clicks into place.                                                   |
|                                                                                                                                                                                | Specimen is not correctly placed on stage.                         | Place specimen correctly.                                                                               |
|                                                                                                                                                                                | Vessel bottom is not flat.                                         | Use an evenly-flat bottomed vessel.                                                                     |
| h) Image is blurred.                                                                                                                                                           | Condenser is not correctly centered.                               | Center condenser.                                                                                       |
|                                                                                                                                                                                | Light source is not correctly centered.                            | Center light source correctly.                                                                          |
|                                                                                                                                                                                | Condenser holder is tilted up.                                     | Lower it to stop position.                                                                              |
| <b>2. Electrical adjustment</b>                                                                                                                                                |                                                                    |                                                                                                         |
| a) Light source is too bright even at lowest bulb voltage.                                                                                                                     | Minimum line voltage adjustment knob is not correctly adjusted.    | Adjust the knob until bulb is dimly lit with sliding control lever at lowest position (nearest to you). |
| b) Light flickers and intensity is unstable.                                                                                                                                   | Line voltage is unstable.                                          | Use voltage stabilizer.                                                                                 |
|                                                                                                                                                                                | Bulb filament is likely to burn out.                               | Replace bulb.                                                                                           |
|                                                                                                                                                                                | Loose electrical connection.                                       | Tighten connections.                                                                                    |
| c) Fuse burns out too often.                                                                                                                                                   | Fuse is not a standard one.                                        | Use standard fuse.                                                                                      |
|                                                                                                                                                                                | Bulb is not a standard one.                                        | Use a halogen bulb as designated (12 V 50W HAL).                                                        |
| d) Pilot lamp lights up but halogen bulb does not when power switch is turned on.                                                                                              | Halogen bulb is burned out.                                        | Replace bulb.                                                                                           |
|                                                                                                                                                                                | No bulb is in socket.                                              | Insert bulb.                                                                                            |
|                                                                                                                                                                                | Loose electric connections.                                        | Tighten connections.                                                                                    |

| Trouble                                                 | Cause                                                            | Remedy                                                                                                                                   |
|---------------------------------------------------------|------------------------------------------------------------------|------------------------------------------------------------------------------------------------------------------------------------------|
| <b>3. Coarse and fine focus adjustments</b>             |                                                                  |                                                                                                                                          |
| a) Coarse adjustment is too tight.                      | Tension adjustment ring is tightened too much.                   | Loosen tension adjustment ring properly.                                                                                                 |
| b) Stage drops and specimen goes out of focus.          | Tension adjustment ring is too loose.                            | Tighten ring properly.                                                                                                                   |
| <b>4. Observation tube</b>                              |                                                                  |                                                                                                                                          |
| a) Incomplete binocular vision.                         | Interpupillary distance is not correctly adjusted.               | Correct interpupillary distance.                                                                                                         |
|                                                         | Diopter adjustment is incomplete.                                | Complete diopter adjustment.                                                                                                             |
|                                                         | User is unaccustomed to binocular vision.                        | Prior to looking at specimen details, try to look at the entire field of view, or look at a far away object before resuming observation. |
| <b>5. Stage</b>                                         |                                                                  |                                                                                                                                          |
| a) Image easily goes out of focus when you touch stage. | Stage is not clamped.                                            | Clamp stage securely.                                                                                                                    |
| b) Specimen stops midway on the east-west traverse.     | Specimen is not correctly positioned on stage.                   | Adjust specimen positioned.                                                                                                              |
|                                                         | Objective is protruding so as to hit against stage insert plate. | Lower nosepiece and then rotate.                                                                                                         |



# **OLYMPUS**

## **OLYMPUS OPTICAL CO., LTD.**

San-Ei Building, 22-2, Nishi Shinjuku 1-chome, Shinjuku-ku, Tokyo, Japan

## **OLYMPUS OPTICAL CO., (EUROPA) GMBH.**

Postfach 104908, Wendenstrasse 14-16, 2000 Hamburg 1, Germany

## **OLYMPUS CORPORATION**

4 Nevada Drive, Lake Success, N.Y. 11042-1179, U.S.A.

## **OLYMPUS OPTICAL CO. (U.K.) LTD.**

2-8 Honduras Street, London EC1YOTX, United Kingdom

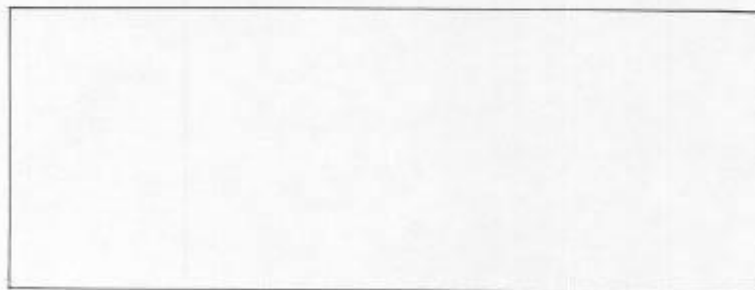

The design of the product is under constant review and whilst every effort is made to keep this manual up to date, the right is reserved to change specifications and equipment at any time without prior notice.