

Muxes Practice

Introduction to Computer Systems, Fall 2024

Instructors: Joel Ramirez Travis McGaha

Head TAs: Adam Gorka Daniel Gearhardt
Ash Fujiyama Emily Shen

TAs:

Ahmed Abdellah

Ethan Weisberg

Maya Huizar

Angie Cao

Garrett O'Malley Kirsch

Meghana Vasireddy

August Fu

Hassan Rizwan

Perrie Quek

Caroline Begg

Iain Li

Sidharth Roy

Cathy Cao

Jerry Wang

Sydney-Shea Cohen

Claire Lu

Juan Lopez

Vivi Li

Eric Sungwon Lee

Keith Mathe

Yousef AlRabiah

pollev.com/tqm

- ❖ What have you heard about CMPE? (Computer Engineering)
 - Ever considered joining it? (Why or Why not)
 - Did you know that it existed?

Upcoming Due Dates

- ❖ HW03 (RPN):
 - Due Last Friday

- ❖ HW04 will release on Friday, will be due before Fall break.
 - **THIS IS A WRITTEN HW, AT MAX 72 HOURS LATE**
 - It should be pretty short.
 - We want to give you some practice on hardware that we are sure we can get graded and back to you before the midterm.
 - Will try to get HW05 back to you before midterm as well, but aren't certain about it.

- ❖ No lecture check-in this week

Tentative Final Exam Scheduling

- ❖ 9am – 11am Monday 12/16/24
- ❖ Probably chem 102?

- ❖ This isn't locked in, but >80% probability

Workload Concerns

❖ **THIS IS AN OLD GRAPH FROM FALL 2021 / FALL 2022**

What you are getting yourself into

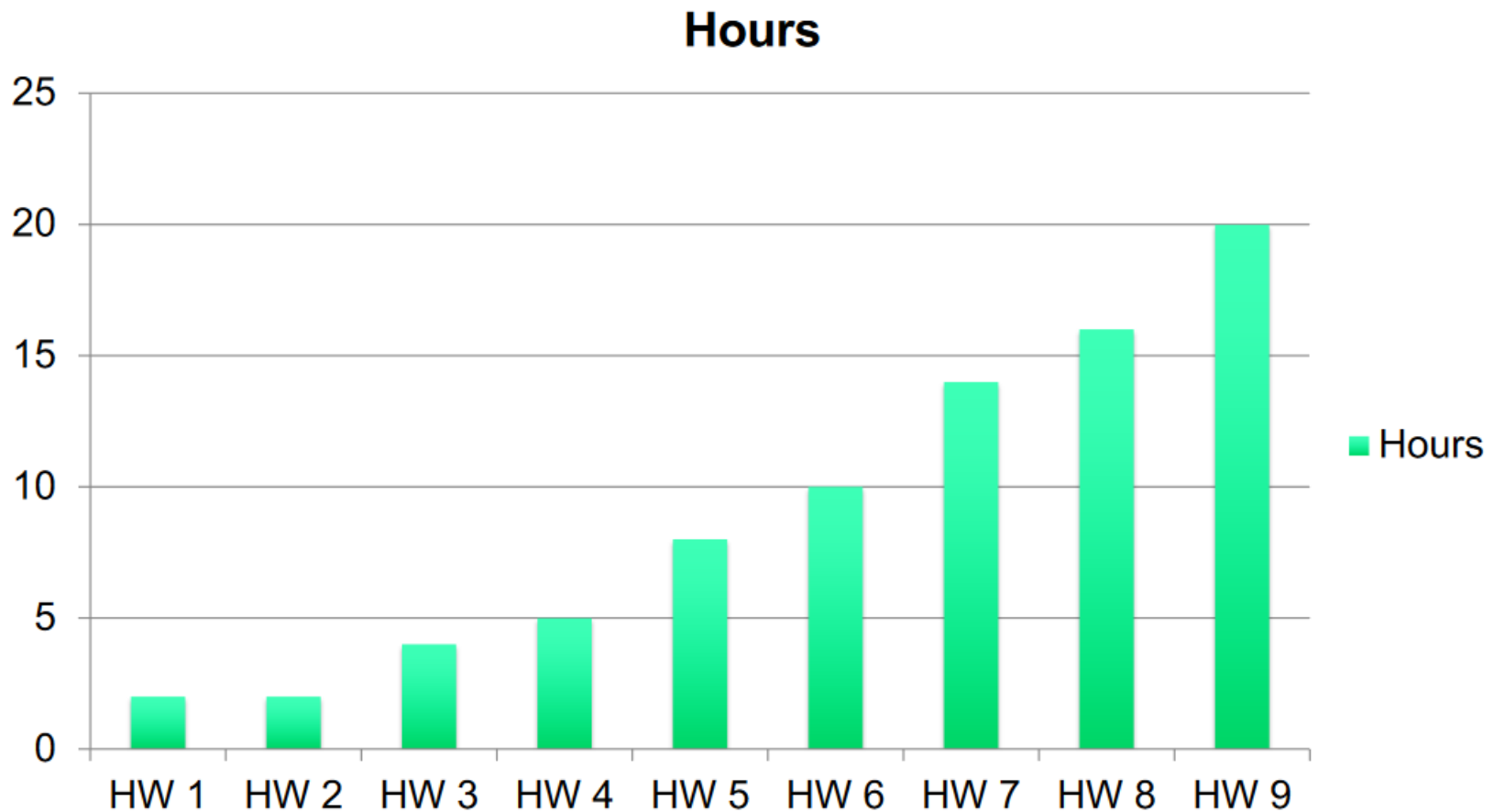

Workload Concerns

❖ If I had to GUESS what it looks like this semester

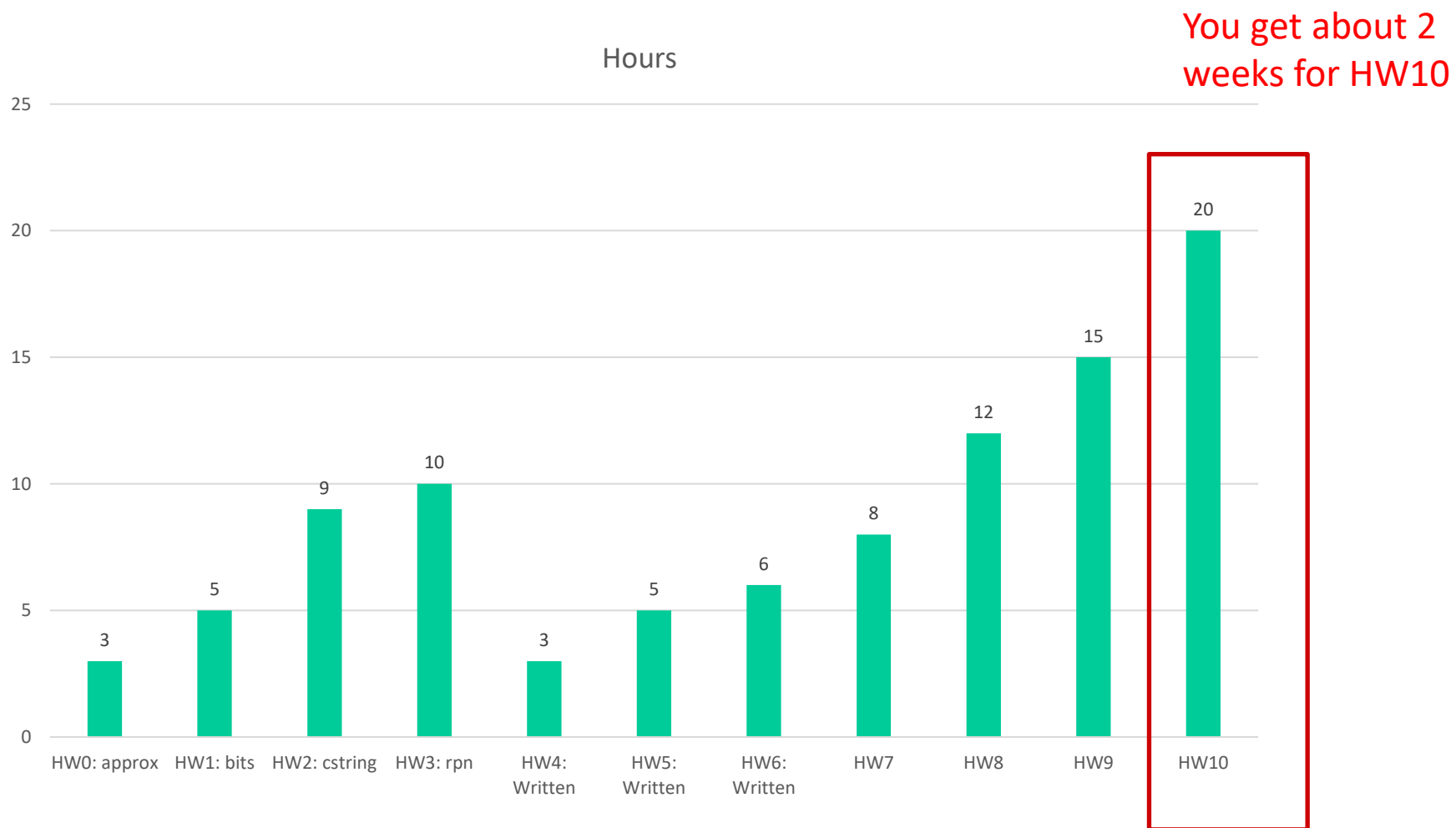

Poll: Interest in Recitation at another time?

Poll: Interest in Saturday Review Session?

- ❖ Some TA's have interest in hosting a session on Saturday's to review the content of the course, go more in depth or talk about advanced applications of the material.
 - This would NOT be for homework questions / Debugging
 - Any interest in this?

Lecture Outline

- ❖ Mux, Saturated Adders, Practice
- ❖ Open-Ended Questions on Anything



pollev.com/tqm

❖ How are you? Any Questions from last lecture?

Saturated Adder

- ❖ Saturated Arithmetic is when arithmetic is bound to a fixed range and overflow would result in the maximum value

- ❖ Consider 4 bit addition:

	Unsigned values	2C values
$ \begin{array}{r} 1010 \\ + 0011 \\ \hline 1101 \end{array} $	(10) (3) (13)	(-6) (3) (-3)

Practice!

❖ Design a saturated Adder. You can use:

- the 4-bit adder we made in last lecture
- Muxes
- Logic Gates

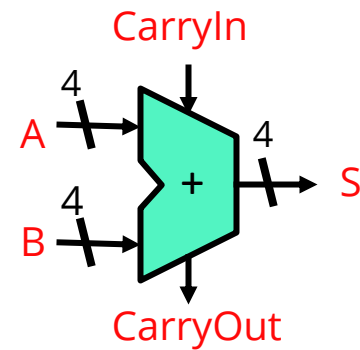
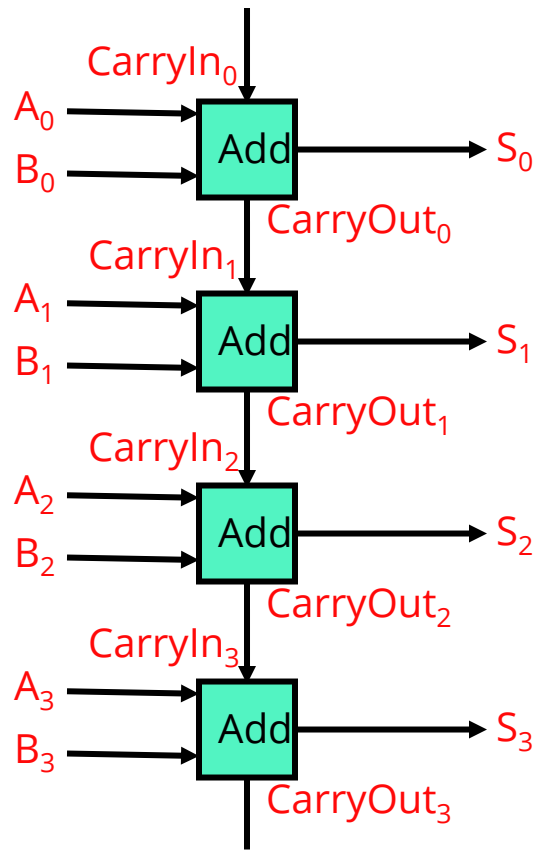

Overflow for 2C

- ❖ Overflow for 2C isn't always "problematic", it doesn't always result in a value that is incorrect.
- ❖ Detection for problematic overflow is different than unsigned
- ❖ Discuss: do you see a pattern for detecting 2C overflow?

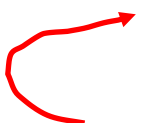
$ \begin{array}{r} \overset{\curvearrowright}{\overset{\curvearrowright}{\overset{\curvearrowright}{\overset{\curvearrowright}{1111}}} \\ + \quad 0001 \\ \hline \underline{10000} \end{array} $	2C (-1) (1) (0)	$ \begin{array}{r} \overset{\curvearrowright}{1000} \\ + \quad 1111 \\ \hline \underline{10111} \end{array} $	2C values (-8) (-1) (7)	$ \begin{array}{r} \overset{\curvearrowright}{\overset{\curvearrowright}{\overset{\curvearrowright}{0111}}} \\ + \quad 0001 \\ \hline \underline{01000} \end{array} $	2C values (7) (1) (-8)
 <p style="color: red; font-style: italic;"> Problematic with unsigned ☹️ but works for 2C! </p>					

Practice!

❖ Design a saturated Adder for 2C. You can use:

- the 4-bit adder we made in last lecture
- Muxes
- Logic Gates

Reminder:

Problematic overflow for 2c when
 $A_3 == B_3$ and $A_3 != S_3$

Different saturated value for
 negative and positive overflow
 1000 and 01111

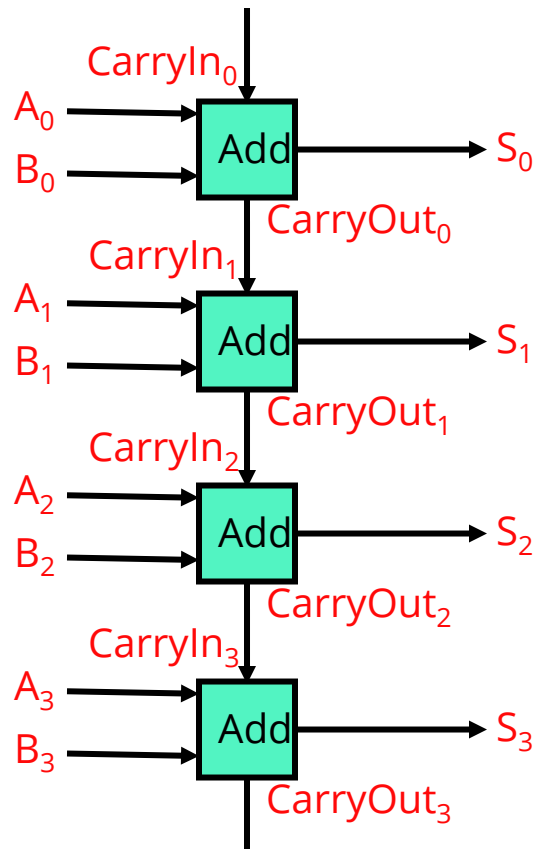

 **Poll Everywhere**pollev.com/tqm

- ❖ Anonymous Poll:
Have you had an internship yet?
 - More than one
 - One
 - Never
 - Prefer not to answer

 **Poll Everywhere**pollev.com/tqm

❖ Anonymous Poll:

What motivates your career in Computing?

- I love CS for CS, I'll be happy as long as I am working on interesting problems
- I love CS but need to find a fulfilling way to apply it (e.g. trying to better the world)
- I Like CS, but I like other things more. If salary differences were not a concern, I may do another STEM related career
- CS is fine, but my true passions lay elsewhere. If money weren't a concern I would not be here
- Prefer not to answer

 **Poll Everywhere**pollev.com/tqm

- ❖ Any questions on anything?
 - Can't answer anything too specific on HW
 - I have OH right after class for HW questions
 - Happy to talk about
 - more advanced material
 - Career stuff
 - Misc programming stuff
 - things not related at all