

ESE3700: Circuit-Level Modeling, Design, and Optimization for Digital Systems

Lec 12: March 19, 2025

Design Space Exploration (con't)

Pass Transistor Logic





Today

- ❑ Pass Transistor Logic
- ❑ Pass Transistor Circuit
 - $C_{\text{diff}} > 0$
 - Output levels
 - Cascading
 - Series pass transistors?
 - Delay

Pass Transistor Logic



Identify Function (Preclass 2)

□ What function is this?

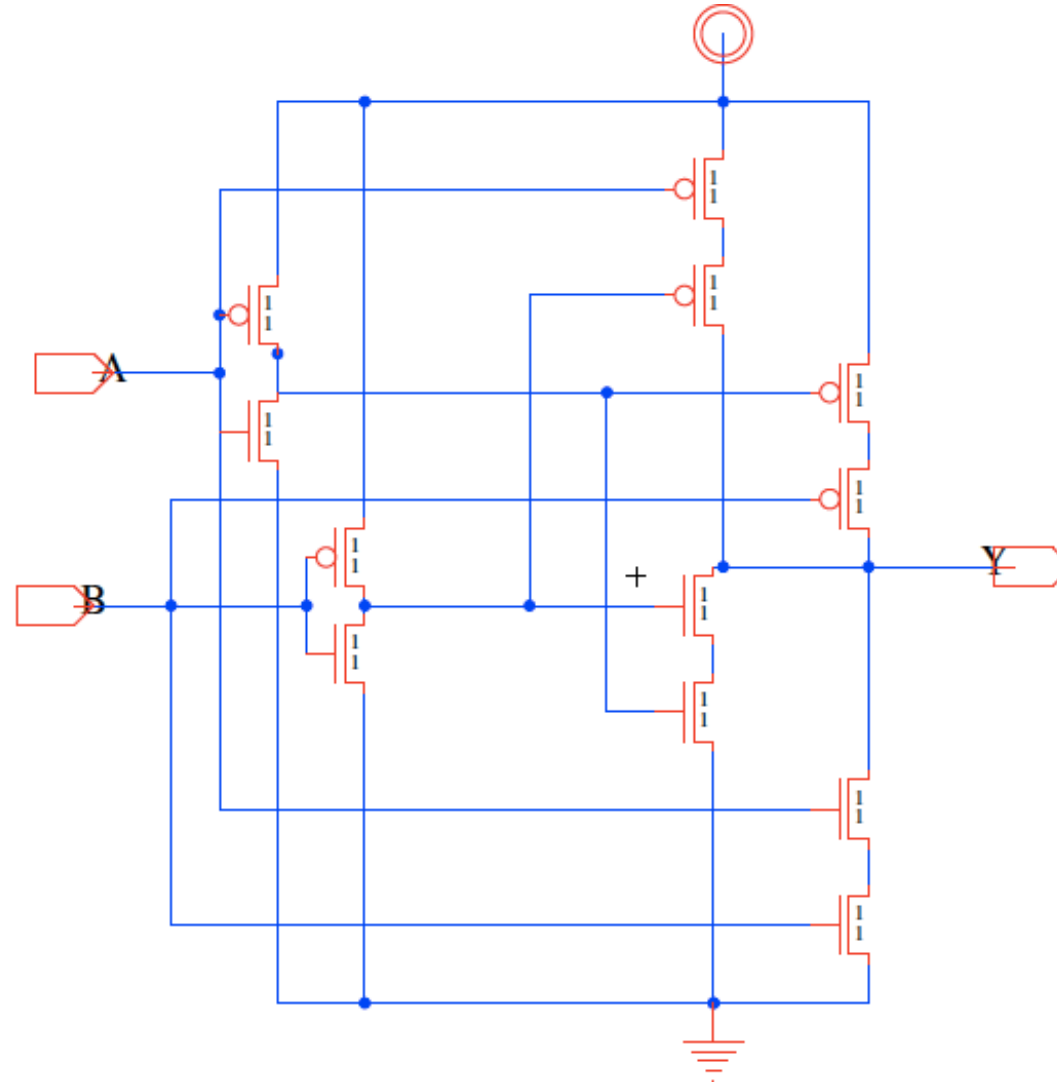

Area

□ Compare PT with CMOS circuit?

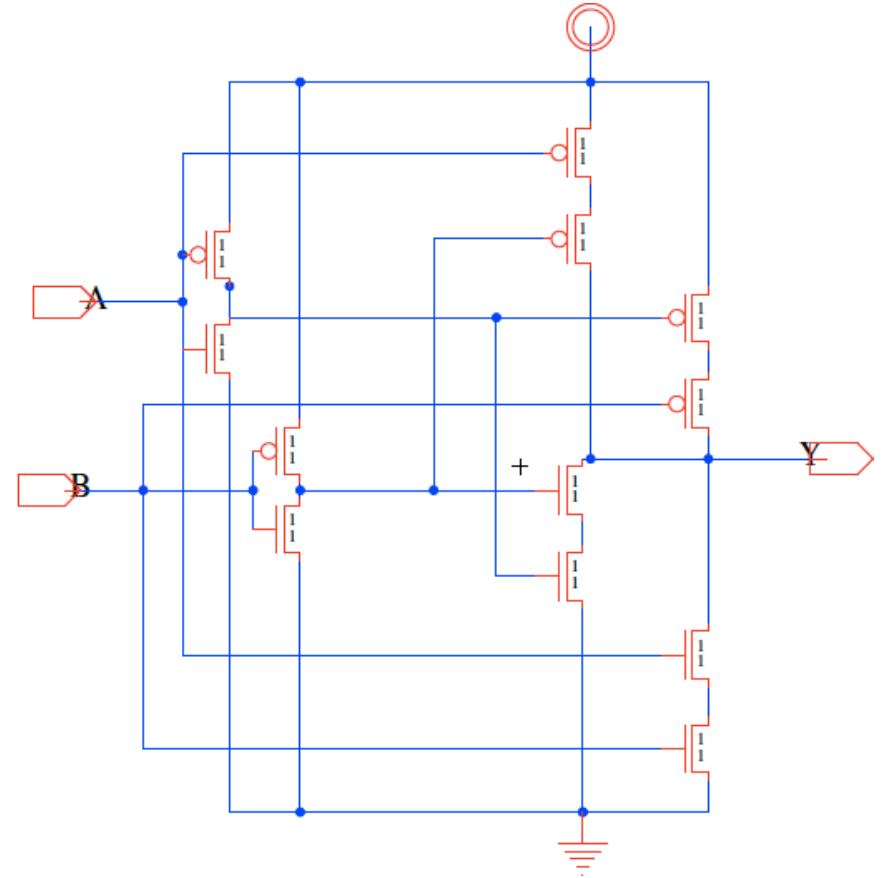
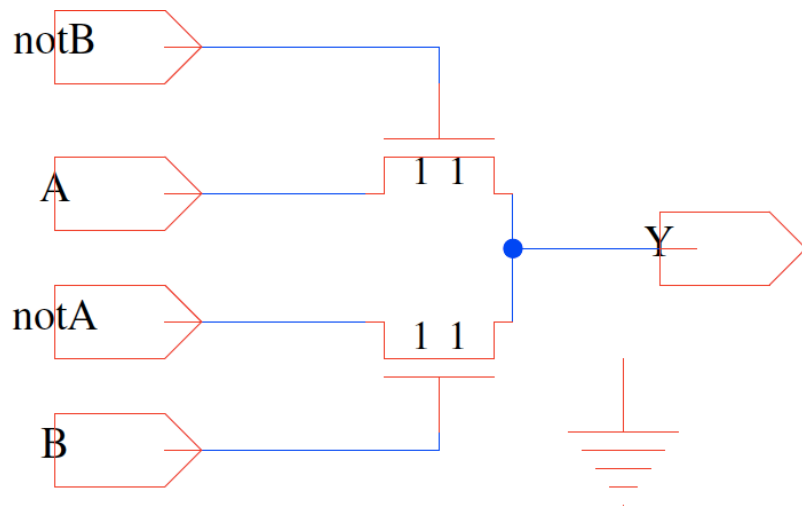



Output

□ Is this a regenerating/restoring gate?

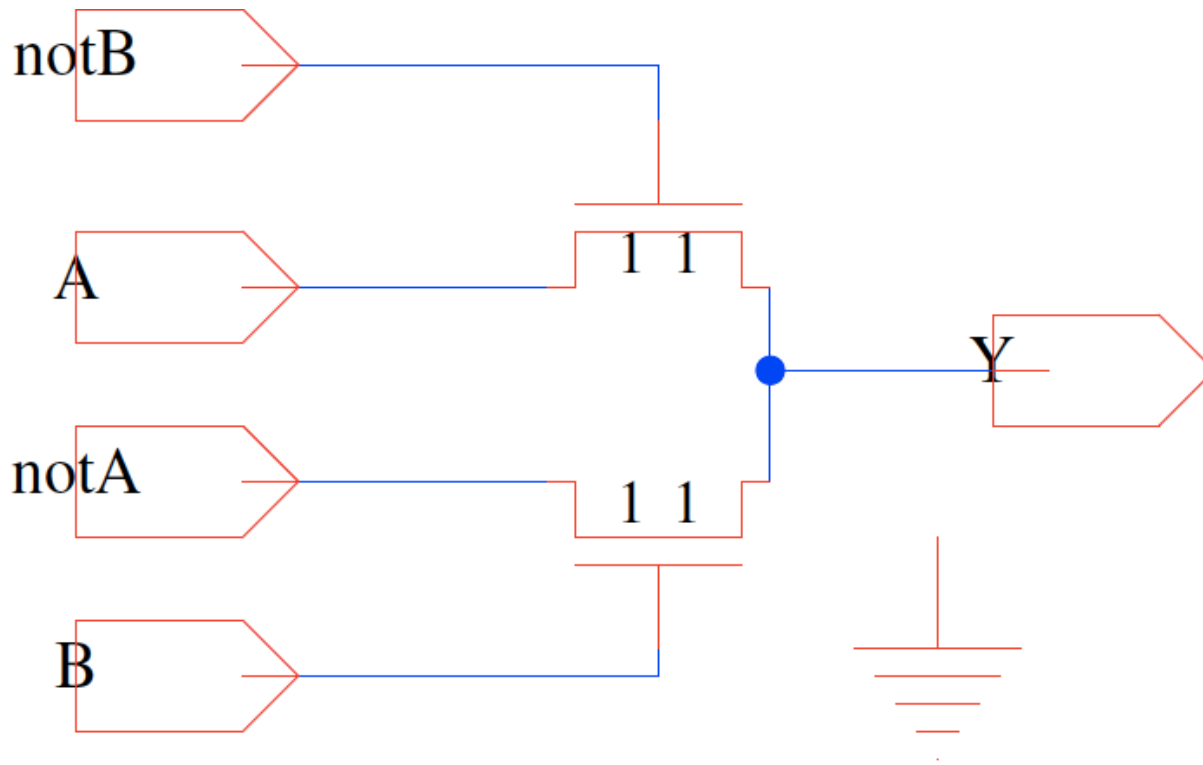

A	B	Y
0	0	0
0	1	1
1	0	1
1	1	0

Output

- What does output look like (DC transfer)?
 - (B=1, notB=0, sweep A, notA=CMOS inv(A))

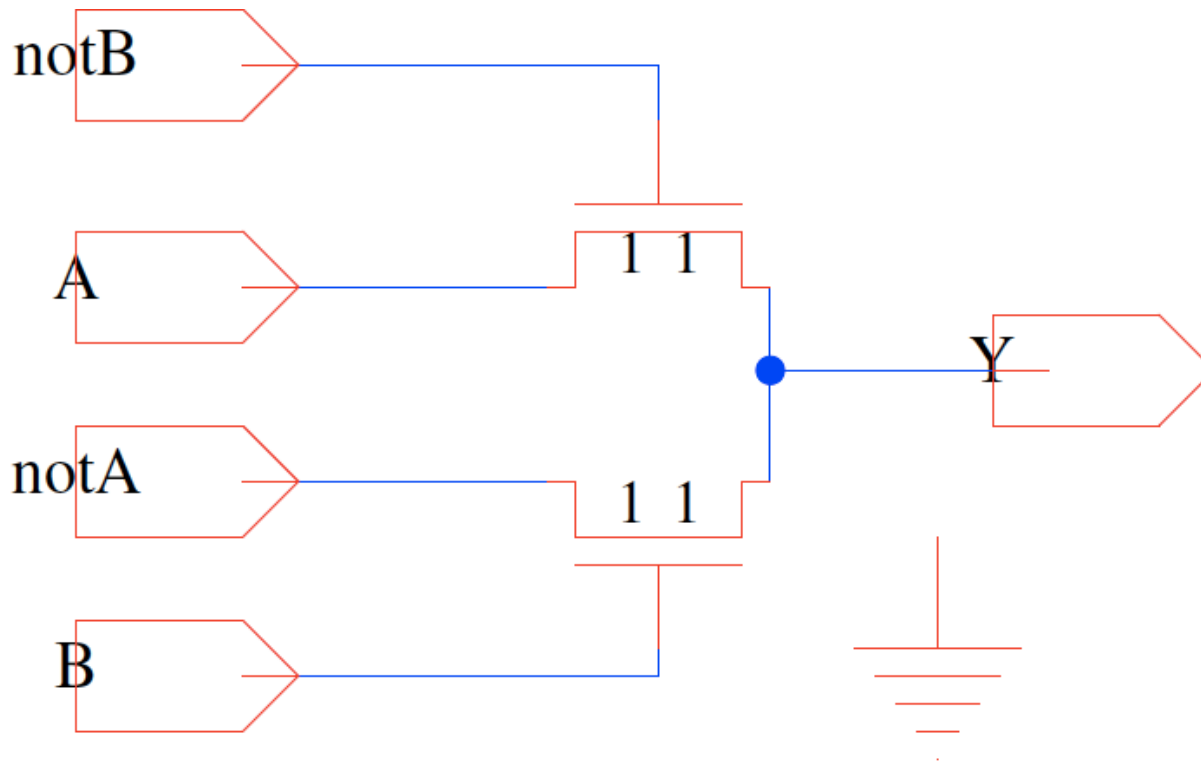

Pass TR transfer (B=1)

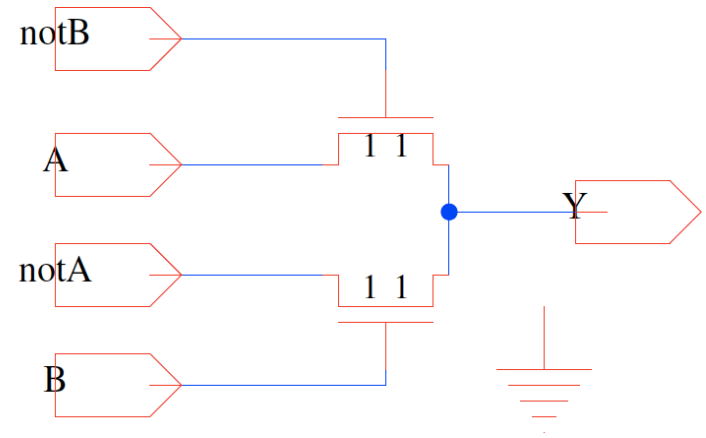

*** spice deck for cell test_passtr_xor2{sch} from library test

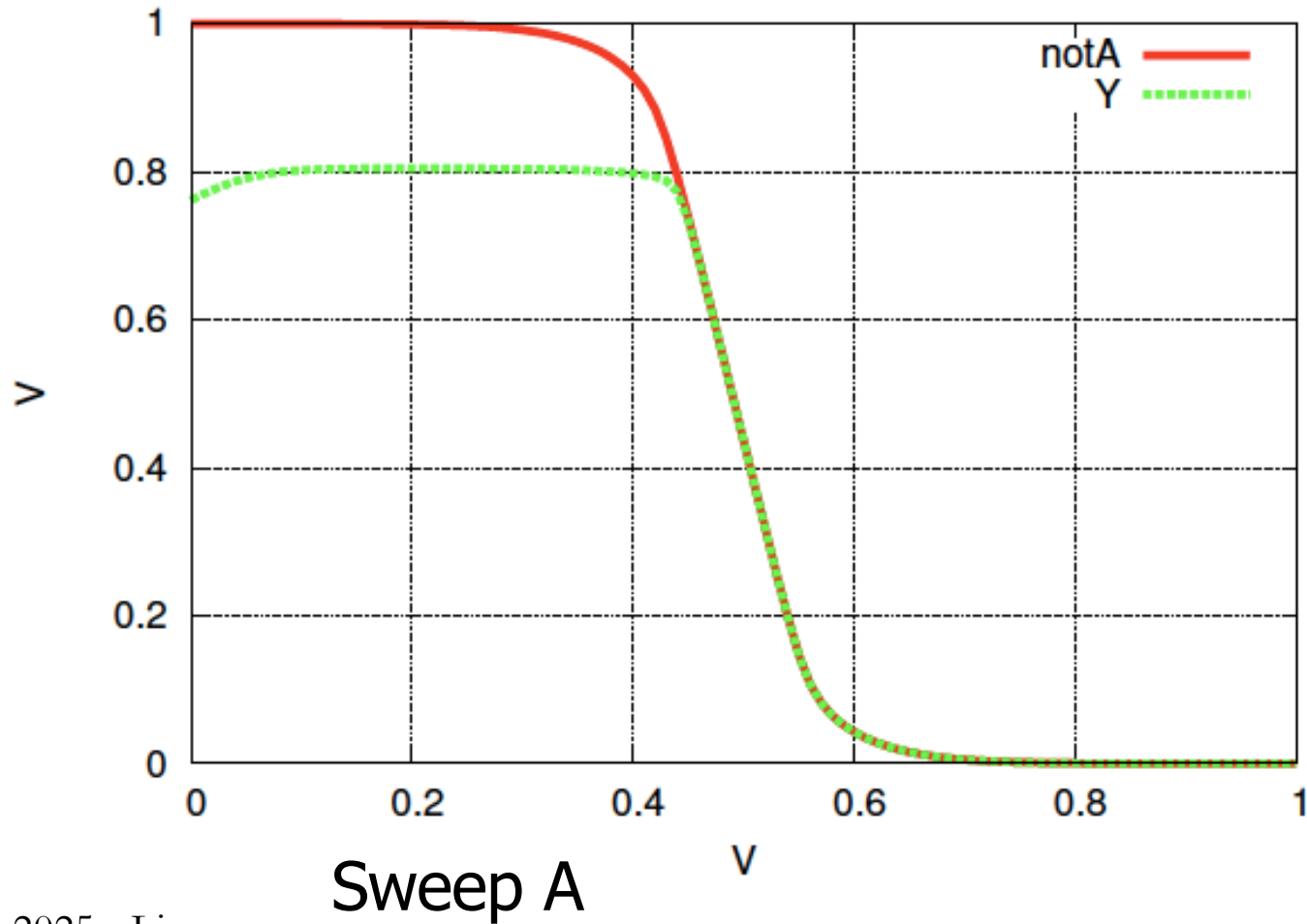



XOR Output

Reasonable Input to CMOS Inverter?

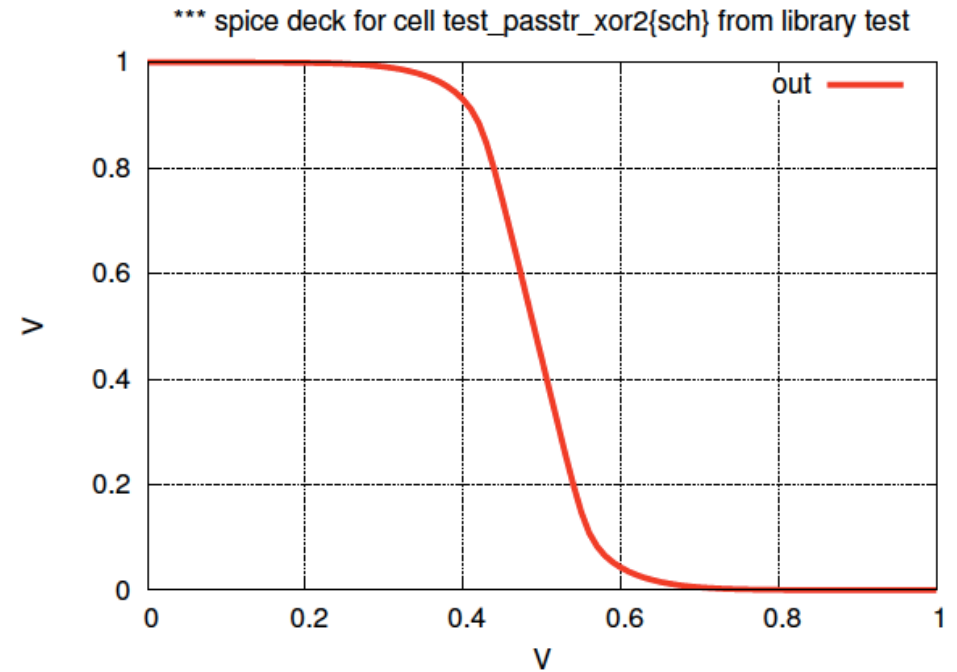
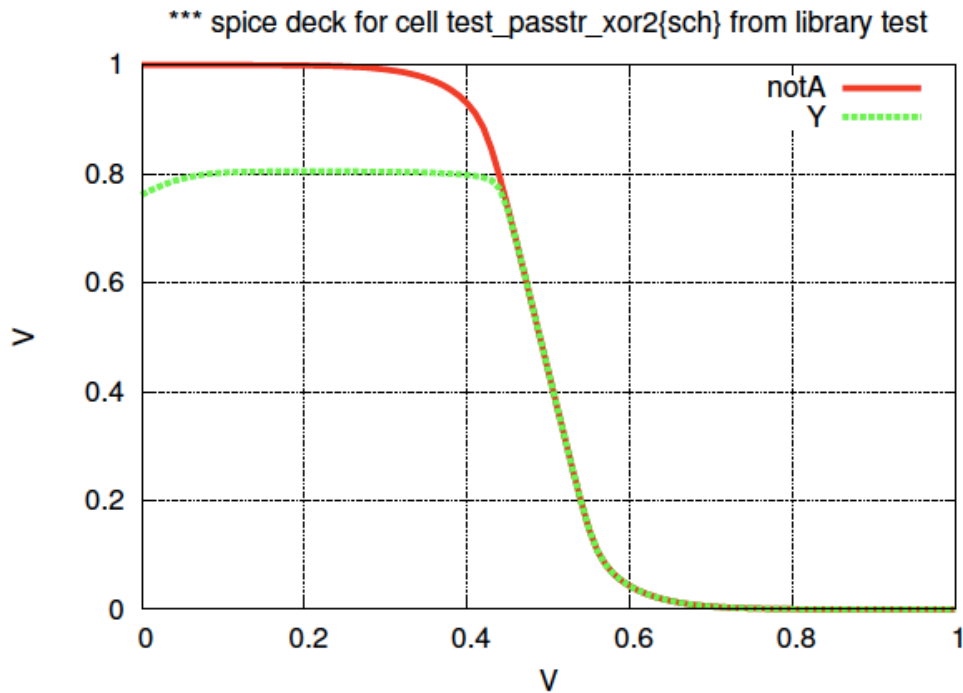

Pass Transistor xor2 with inv restore

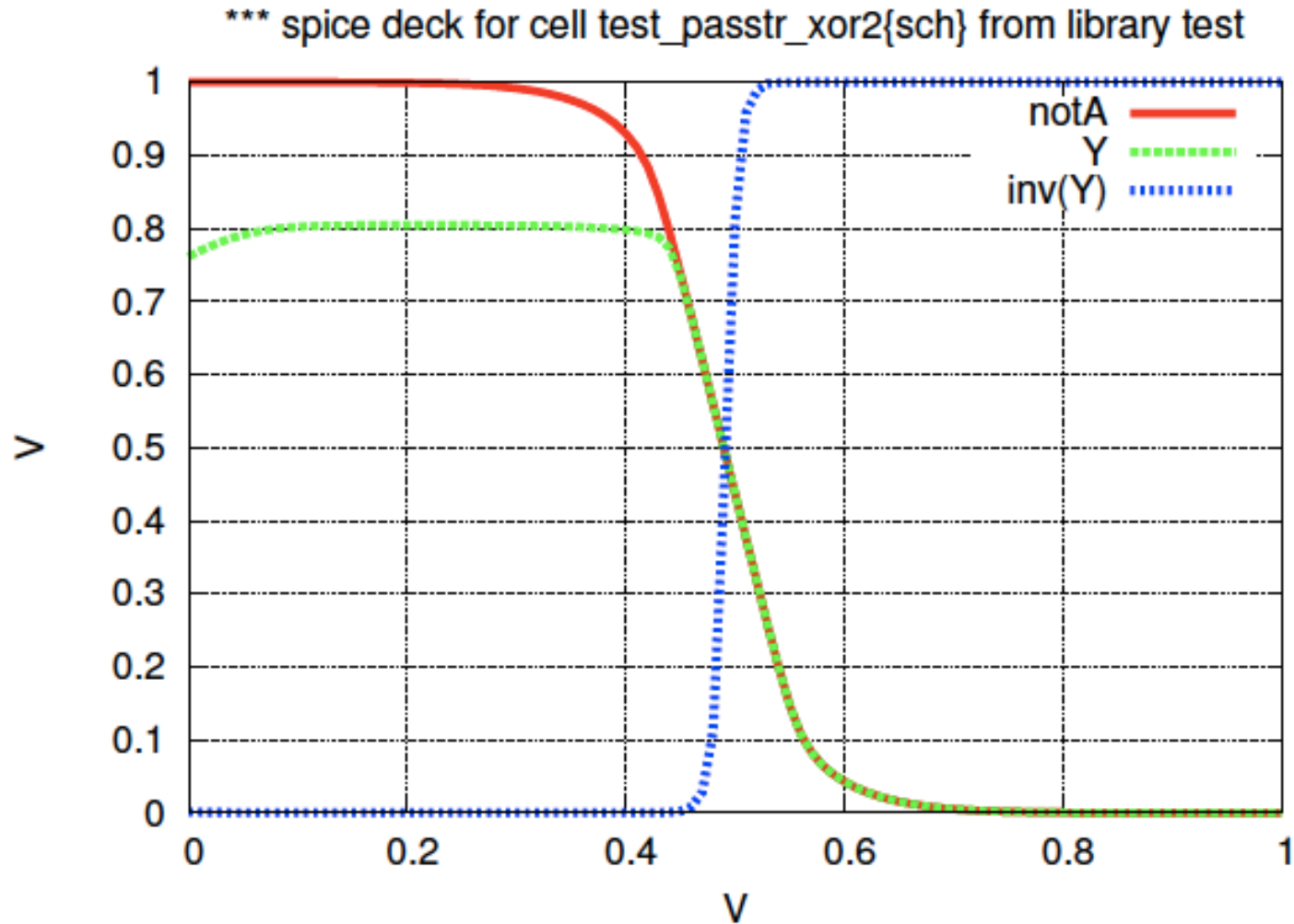



Required to use?

- ❑ What should we add to make suitable comparison with CMOS?

Restore Output

- What should we add to make suitable comparison with CMOS?

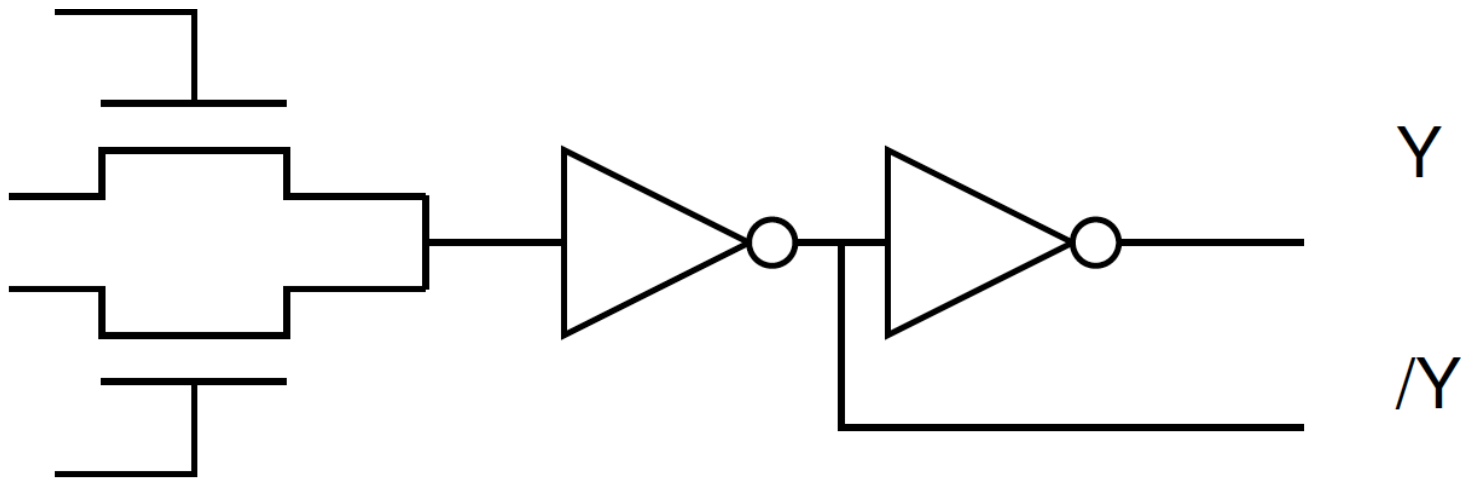

Restore Output

- Area? (compare to CMOS)

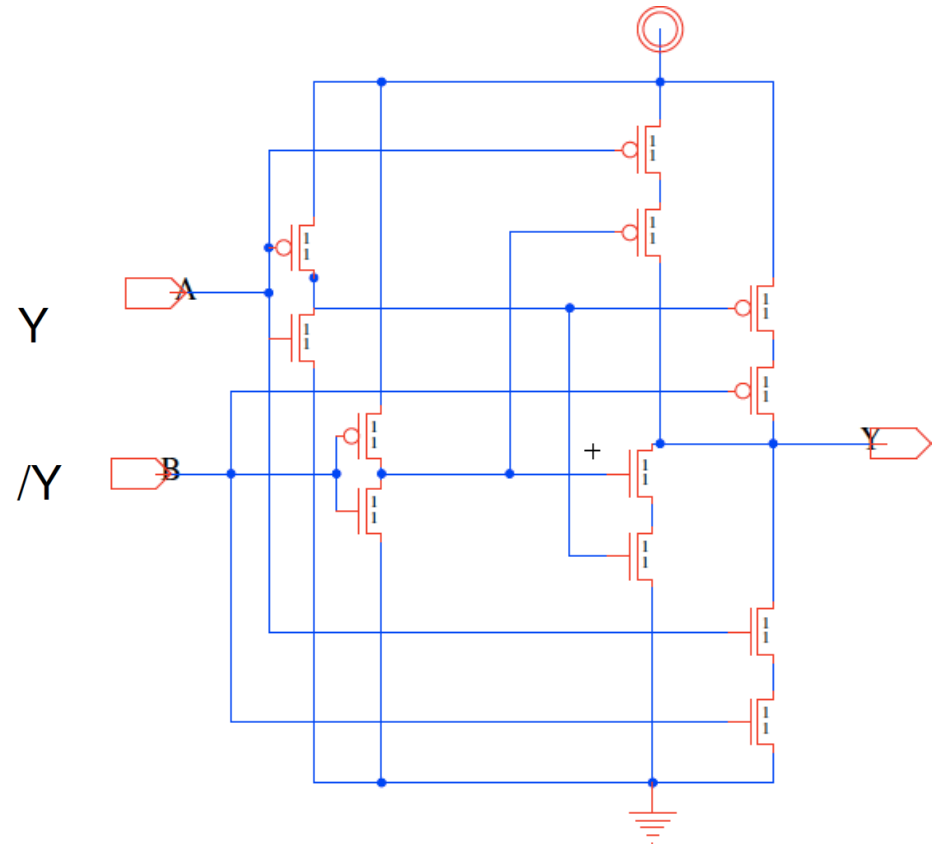
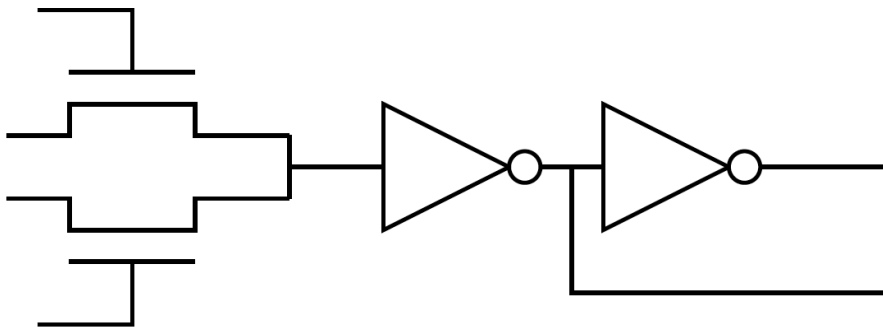



Chain Together

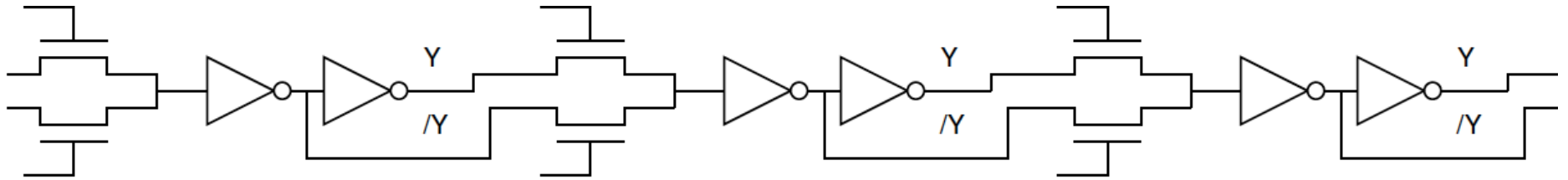

Analyze Stage

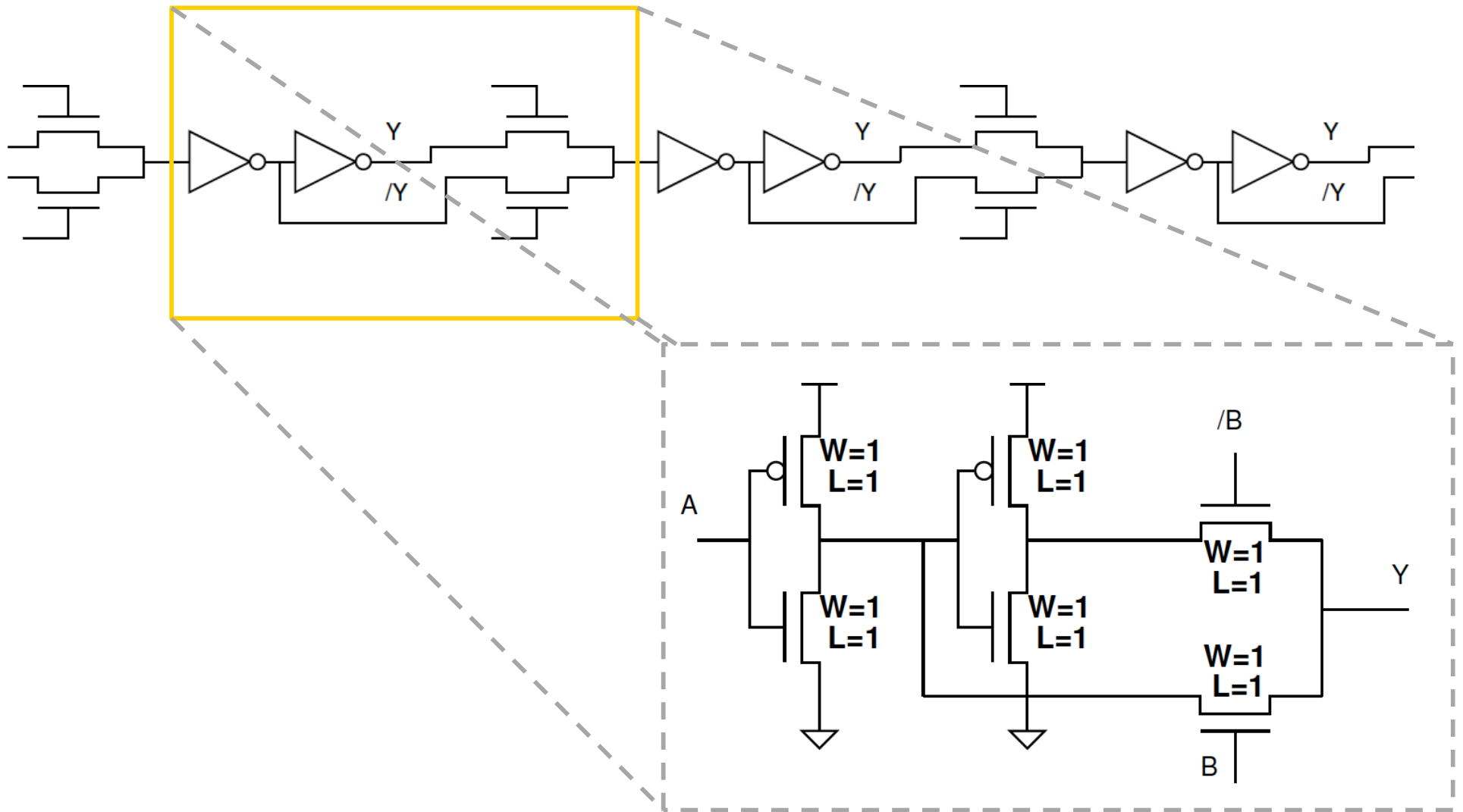

Impact of Capacitance

- ❑ $C_{GS} = C_{GCS} + C_{GSO}$
- ❑ $C_{GD} = C_{GCD} + C_{GDO}$
- ❑ $C_{GB} = C_{GCB}$
- ❑ $C_{SB} = C_{diff}$
- ❑ $C_{DB} = C_{diff}$

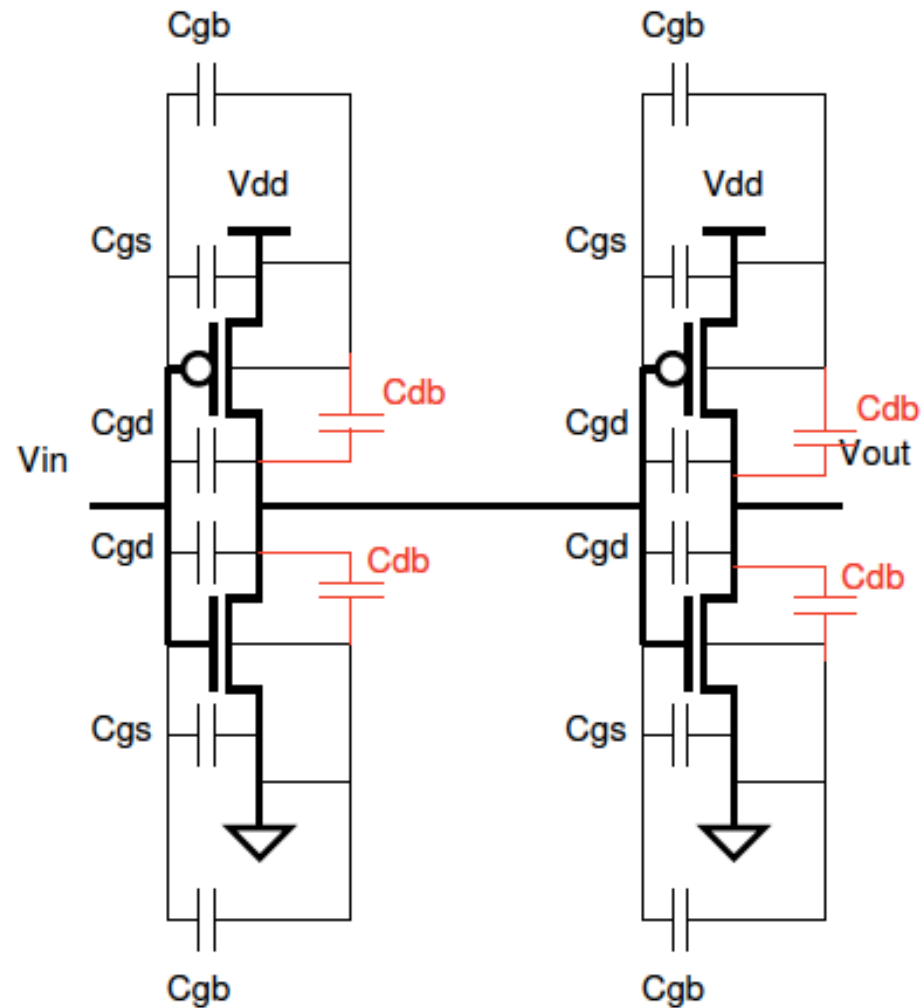

Contact/Diffusion Capacitance

- C_j – diffusion depletion
- C_{jsw} – sidewall capacitance
- L_S – length of diffusion

$$C_{diff} = C_j L_S W + C_{jsw} (2L_S + W)$$

Define: $C_{diff0} \approx \gamma C_0$

$$C_{diff} \approx WC_{diff0} = W \cdot \gamma C_0$$

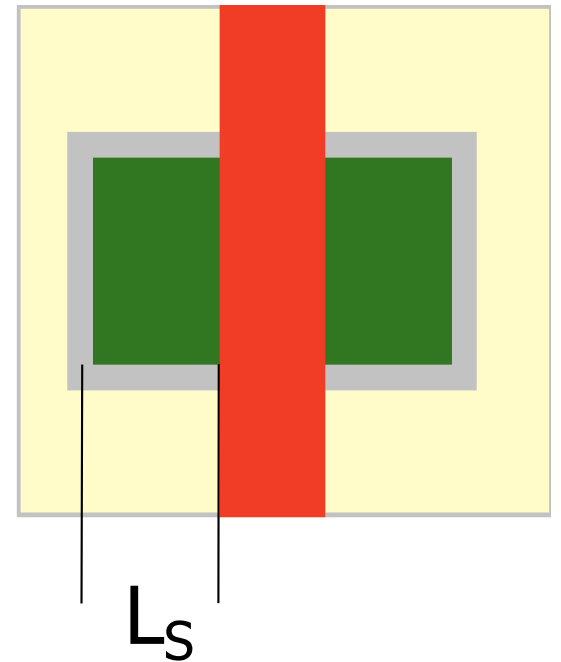

First Order Model

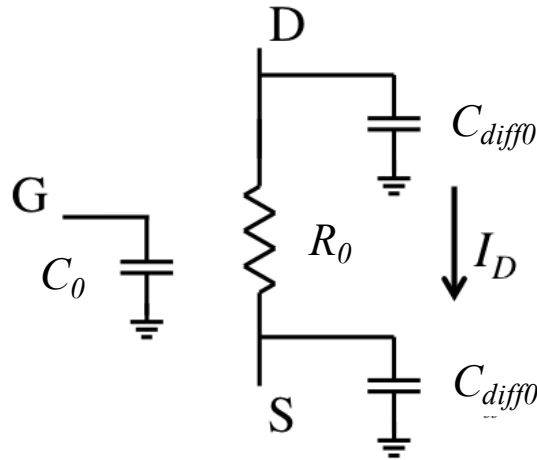

□ Switch

- Loads **all terminals** capacitively
 - Draw no steady-state current for a CMOS gate
 - Does not impact steady-state output voltage
 - Impacts Settling time/Delay
- Has finite drive strength
 - Could form voltage divider with resistive load
 - Impacts Settling time/Delay

First Order Delay

- R_0 = Resistance of minimum size NMOS device
- C_0 = gate capacitance of minimum size NMOS device
- C_{diff0} = diffusion capacitance on minimum size NMOS
 - $C_{diff0} = \gamma C_0$
- $R_{drive} = R_0/W$
- $C_g = WC_0$
- $C_{diff} = WC_{diff0} = \gamma WC_0$

Delay $A=1, B=0, C_{diff0}=\gamma C_0?$ (Preclass 3)

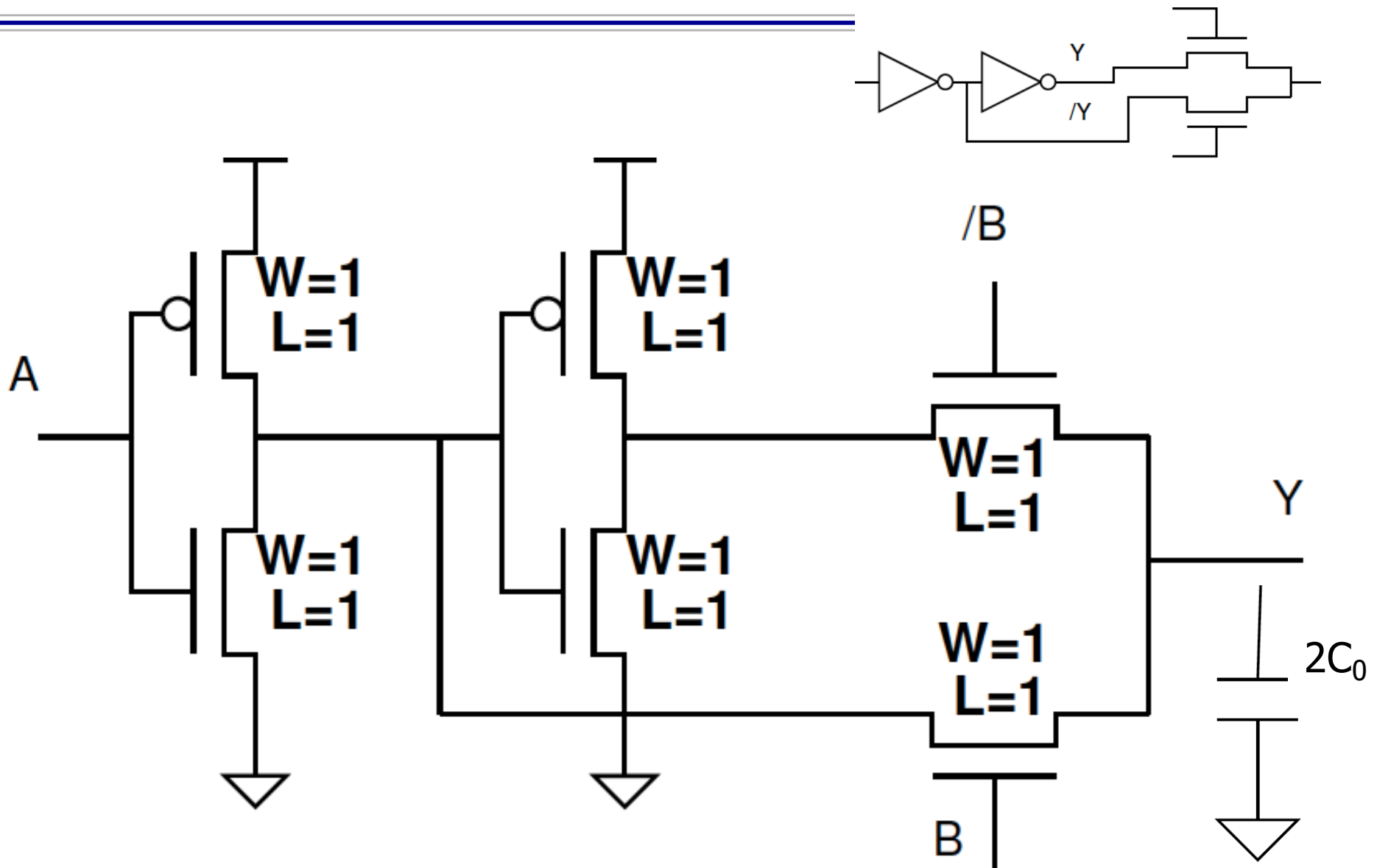

Delay $A=1$, $B=0$, $C_{diff0}=\gamma C_0$? (Preclass 3)

- What's the equivalent RC circuit?

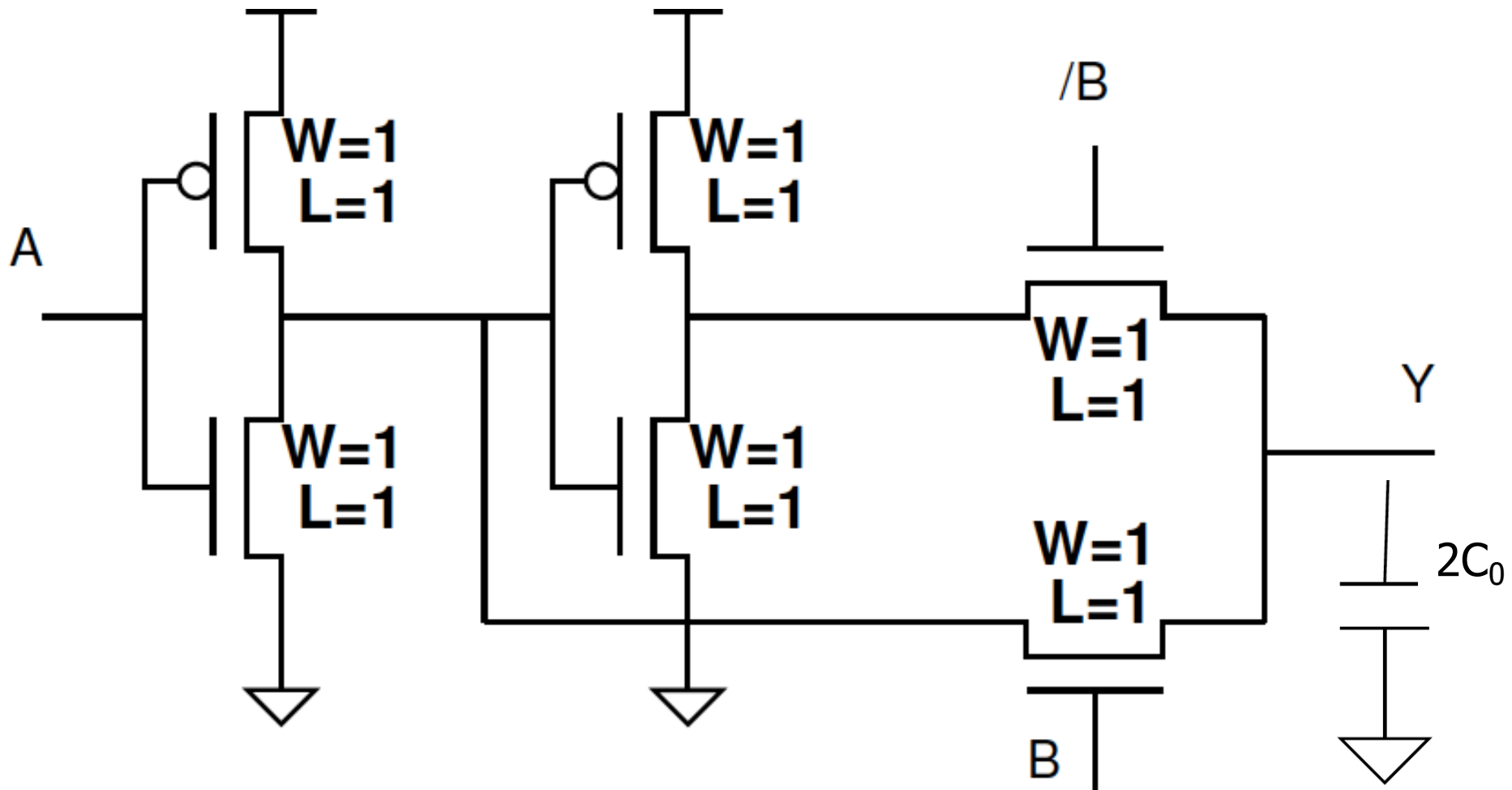

Delay $A=1, B=0, C_{diff0}=\gamma C_0$? (Preclass 3)

- What's the equivalent RC circuit?

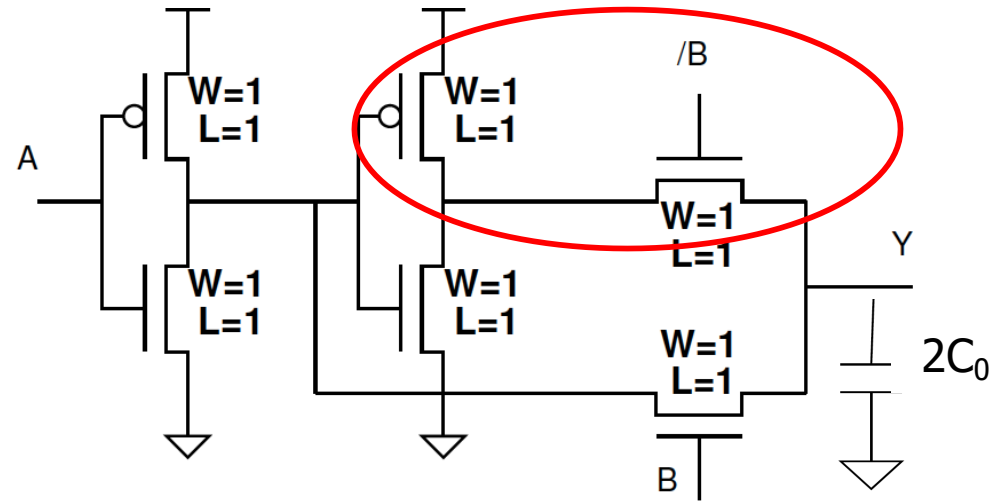

Delay $A=1, B=0, C_{diff0}=\gamma C_0$? (Preclass 3)

- What's the equivalent RC circuit?

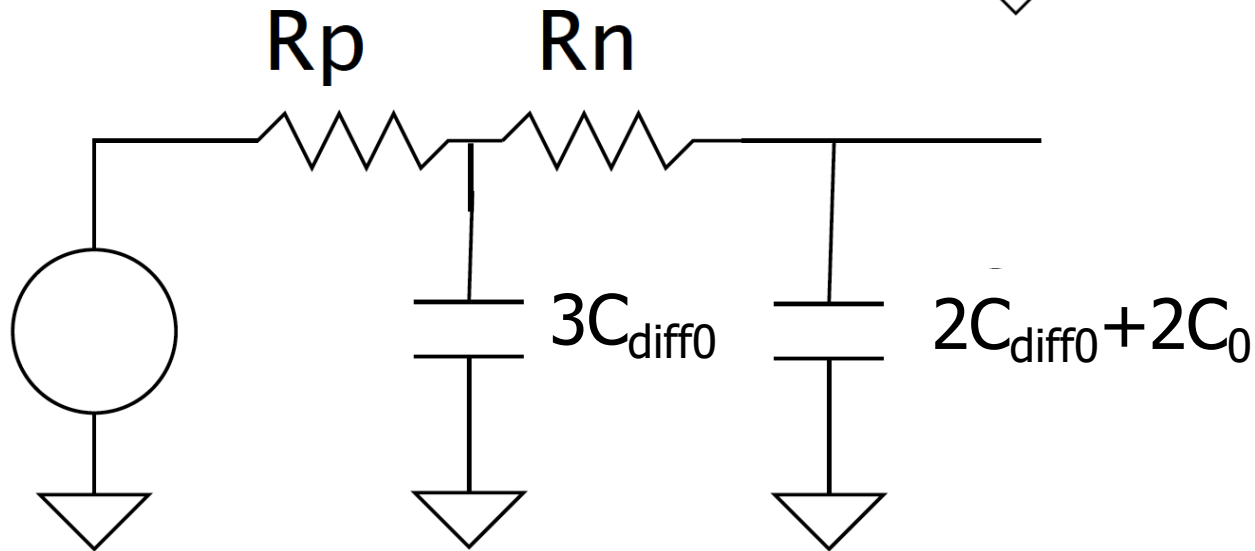
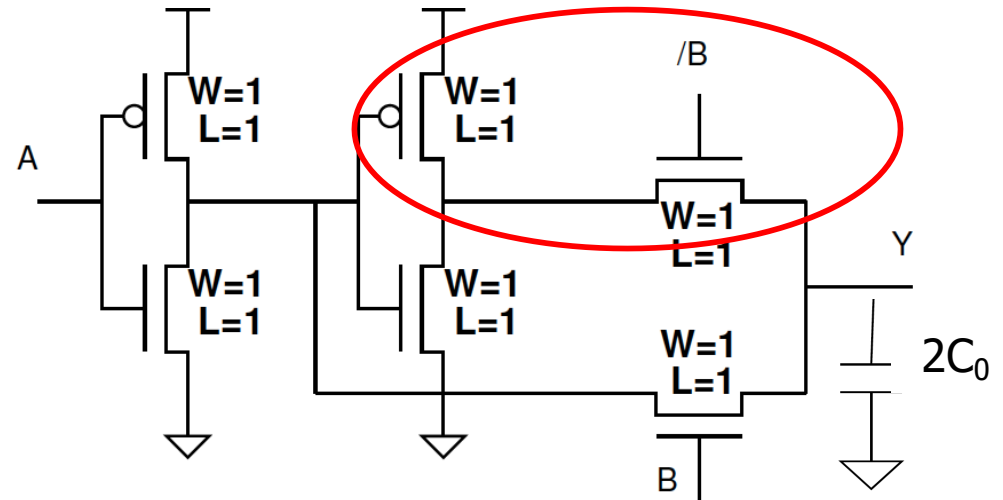

Delay $A=1, B=0, C_{diff0}=\gamma C_0$? (Preclass 3)

- What's the equivalent RC circuit?
 - Delay from A to Y?

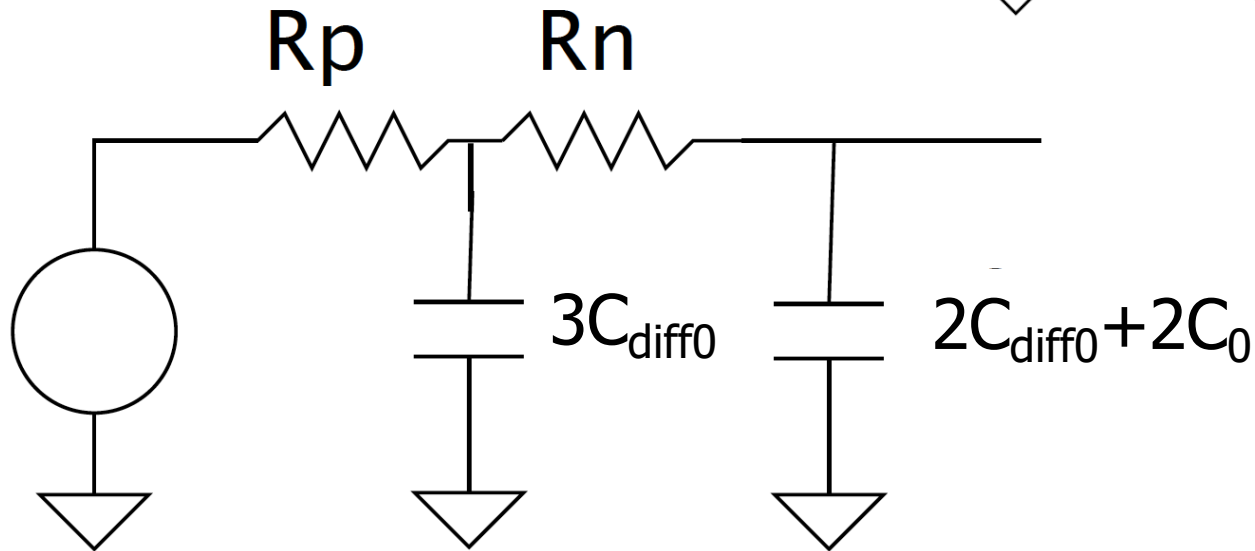
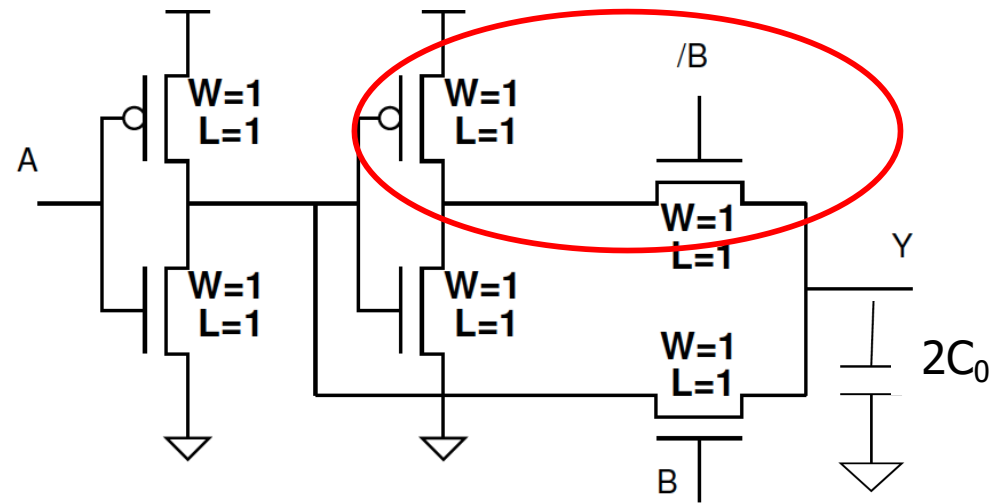

Delay $A=1, B=1, C_{diff0}=\gamma C_0?$ (Preclass 3)

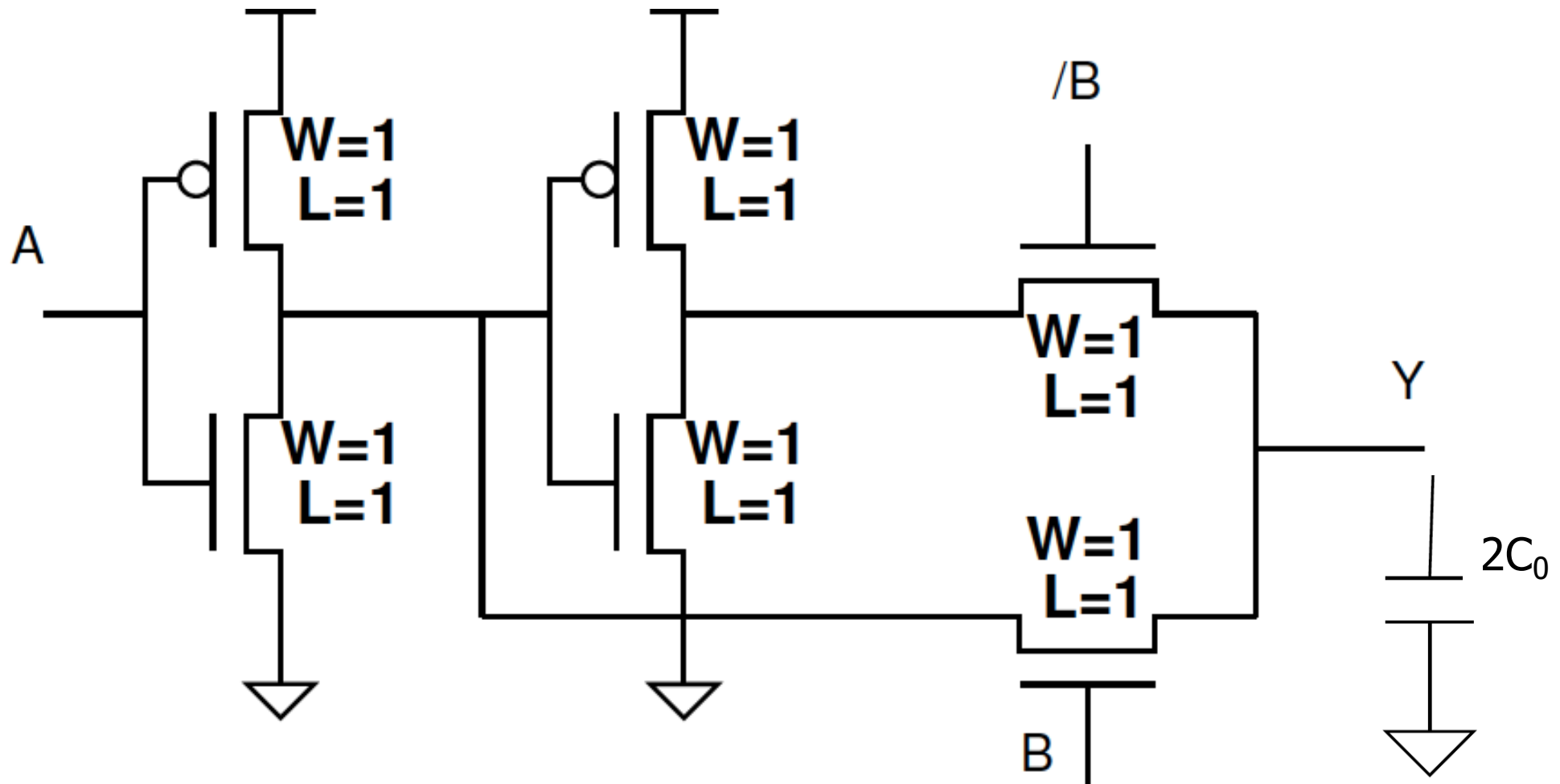

Delay $A=1, B=1, C_{diff0}=\gamma C_0$? (Preclass 3)

- What's the equivalent RC circuit?

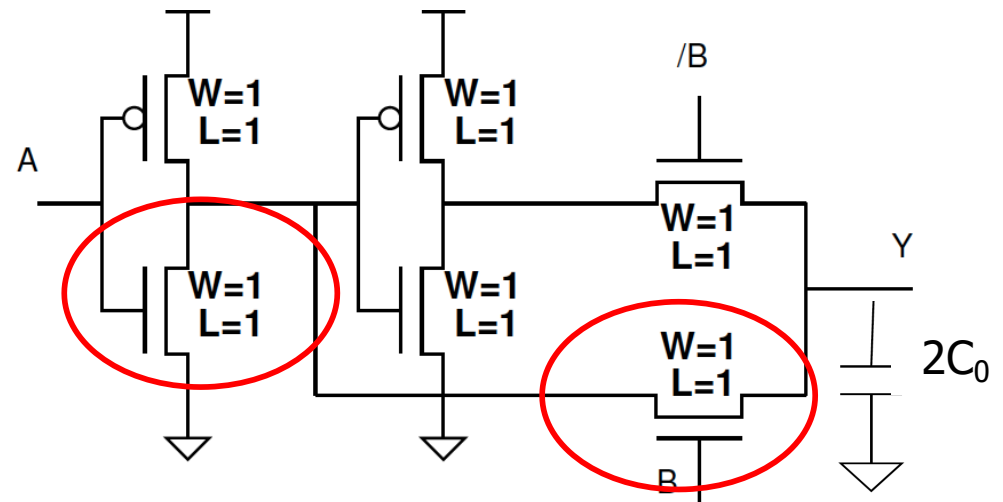

Delay $A=1, B=1, C_{diff0}=\gamma C_0$? (Preclass 3)

- What's the equivalent RC circuit?

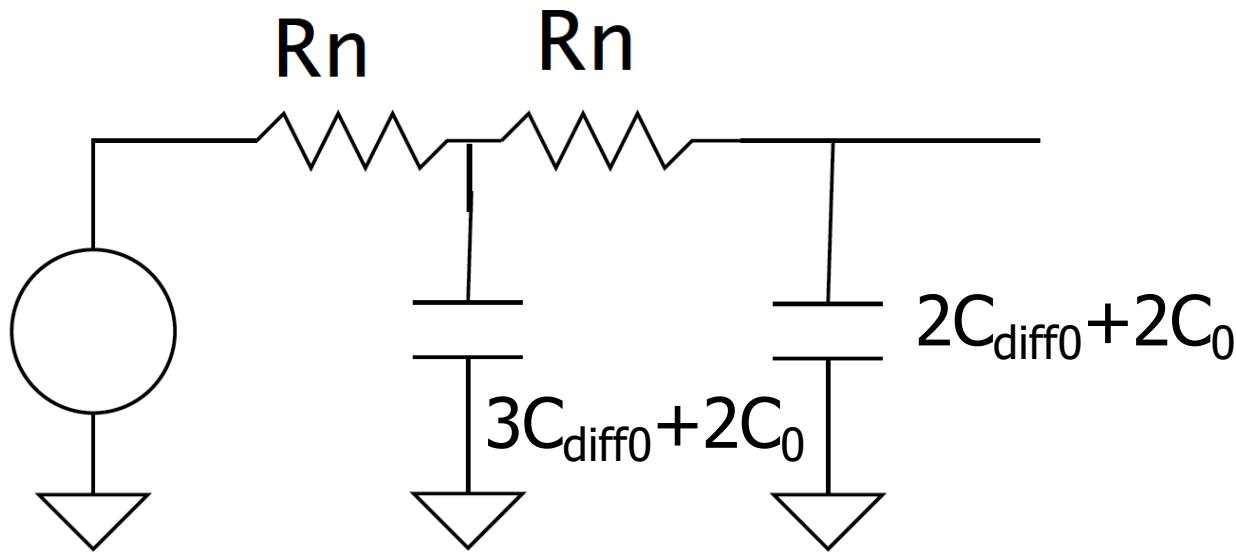
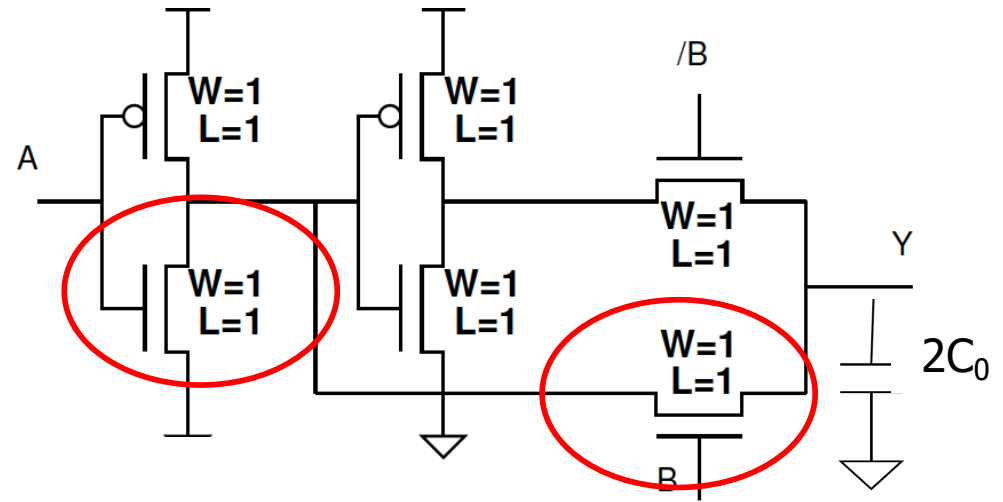



Bonus

□ What does this do?

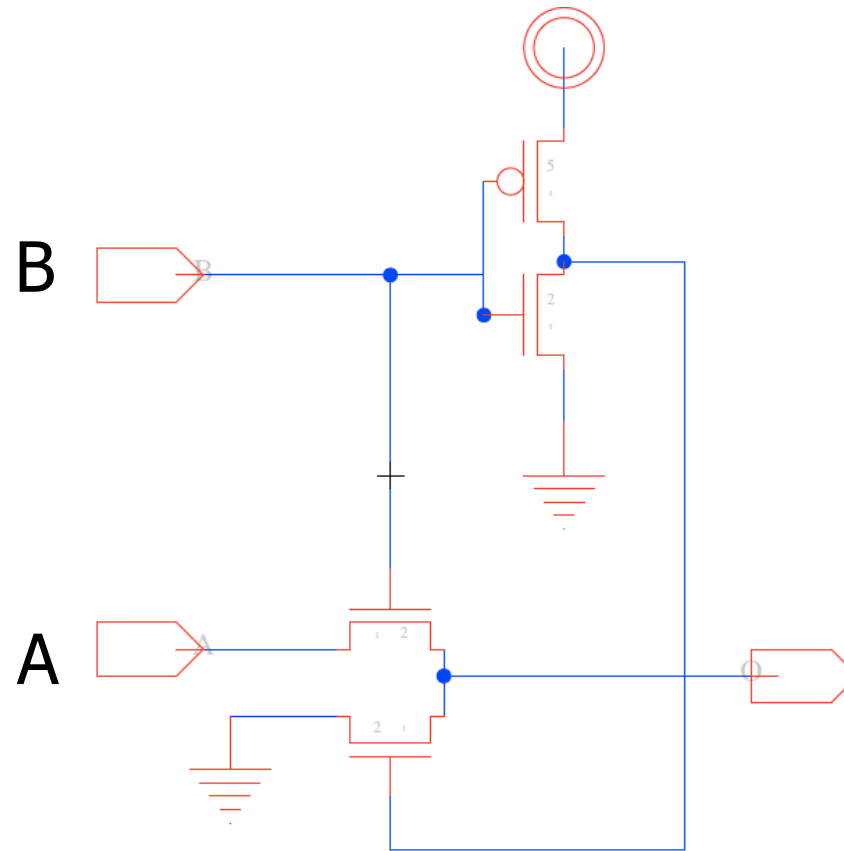

A	B	Y
0	0	
0	1	
1	0	
1	1	



Bonus

□ What does this do?

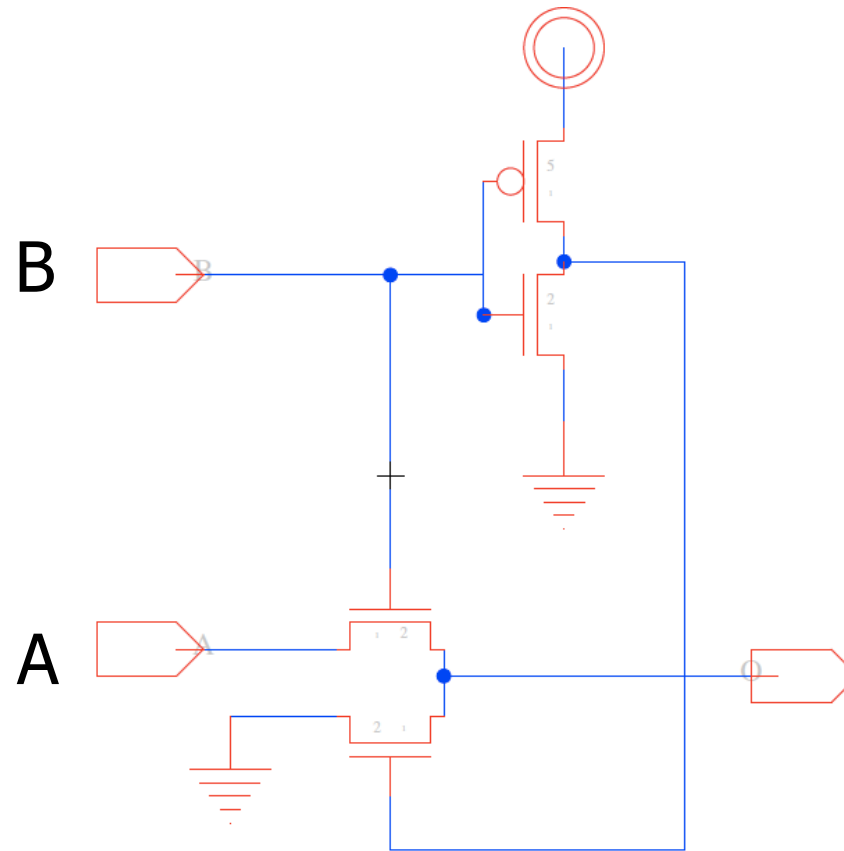

A	B	Y
0	0	0
0	1	0
1	0	0
1	1	1

More examples in the text

Cascading Pass Transistors





Chain without Inverters

□ What if we did this?

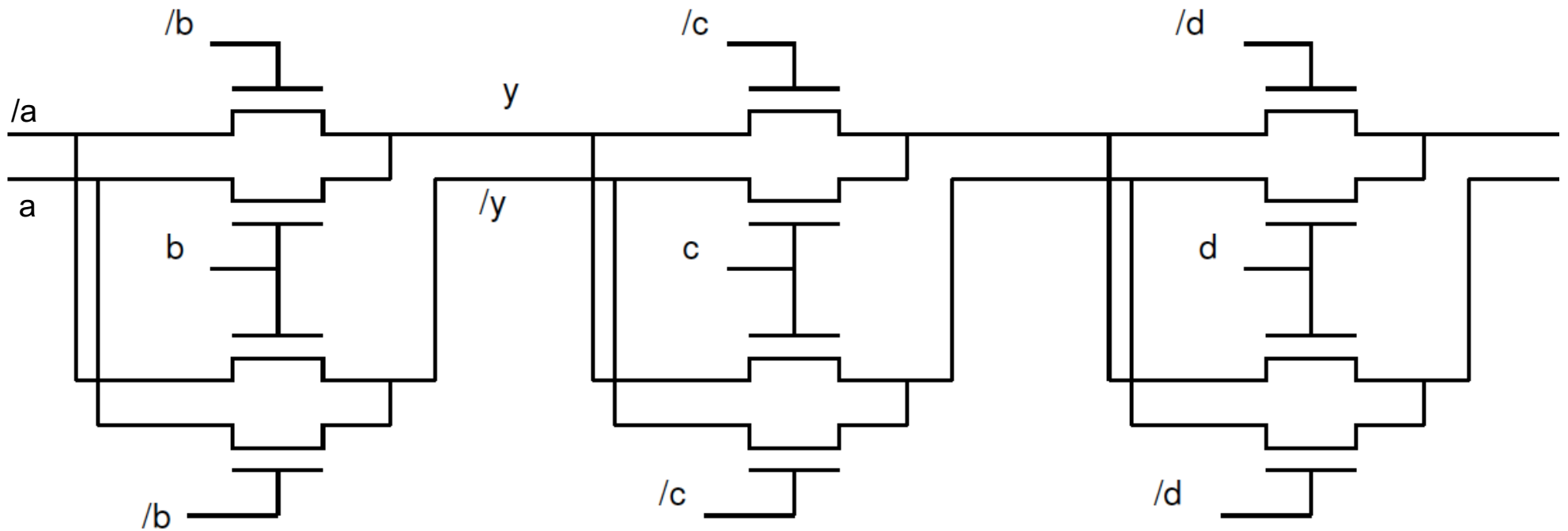

Chain without Inverters

- Extract key path

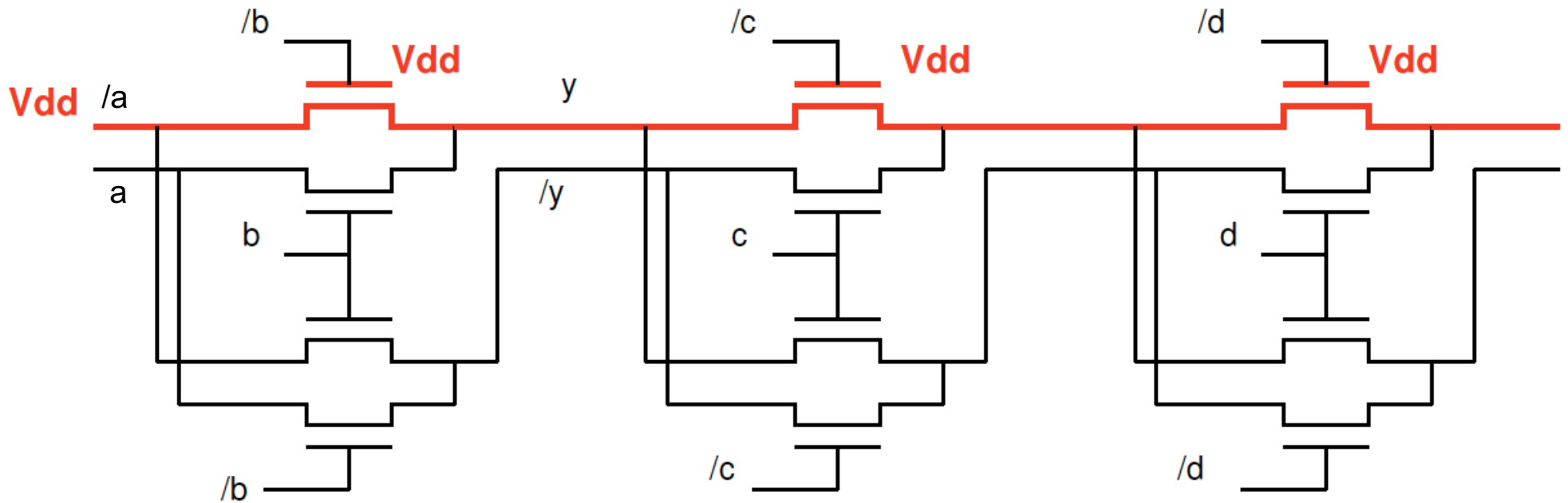

Voltage of Chain (Preclass 4)

□ What is voltage at output?

$$V_{dd} = 1V$$

$$V_{thn} = -V_{thp} = 0.3V$$

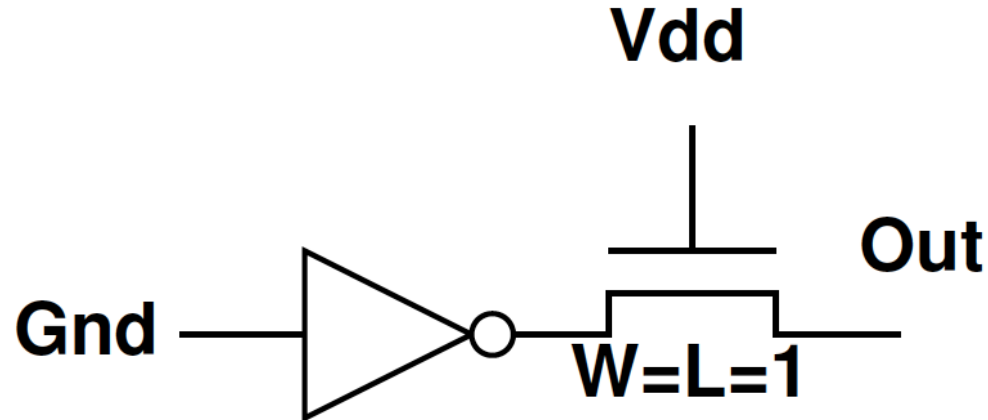

Voltage of Chain (Preclass 4)

□ What is voltage at output?

$$V_{dd} = 1V$$

$$V_{thn} = -V_{thp} = 0.3V$$

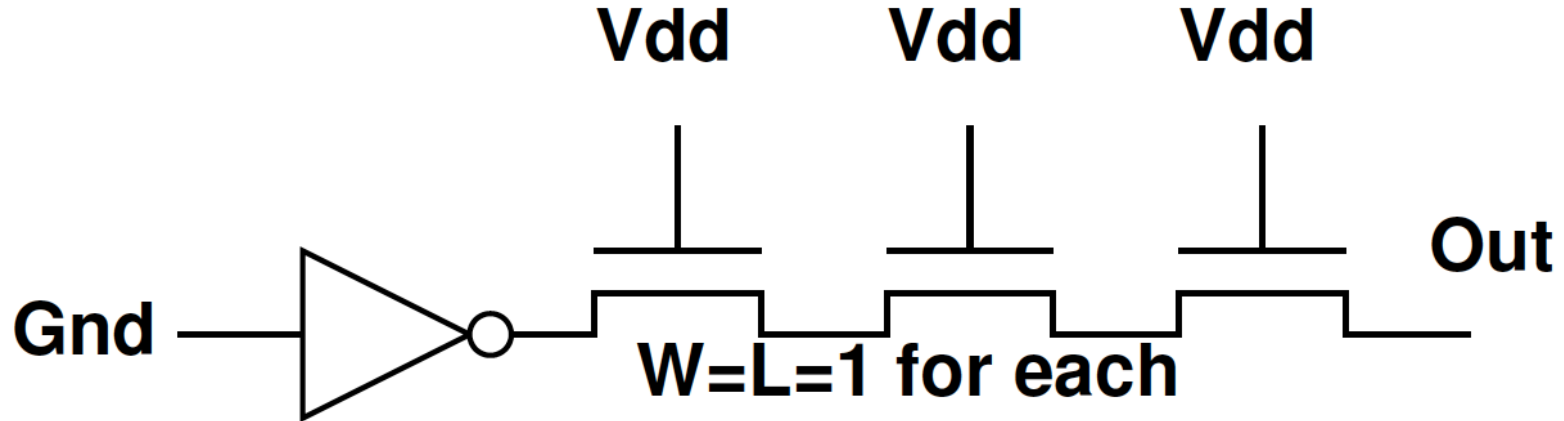

How compare (Preclass 4)

□ Compare

$$V_{dd} = 1V$$
$$V_{thn} = -V_{thp} = 0.3V$$

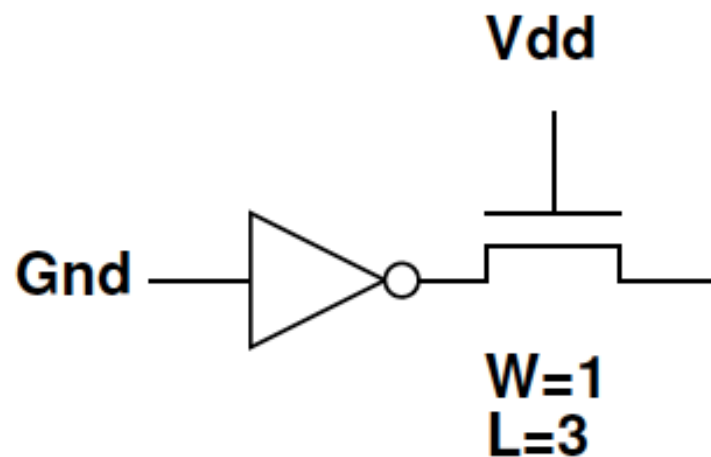
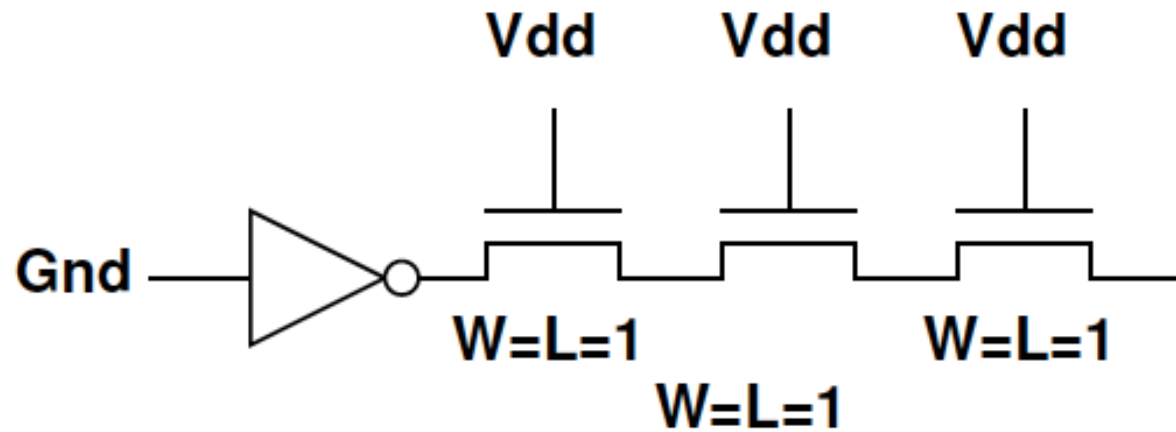

DC Analysis – chain of 3 vs length of 3

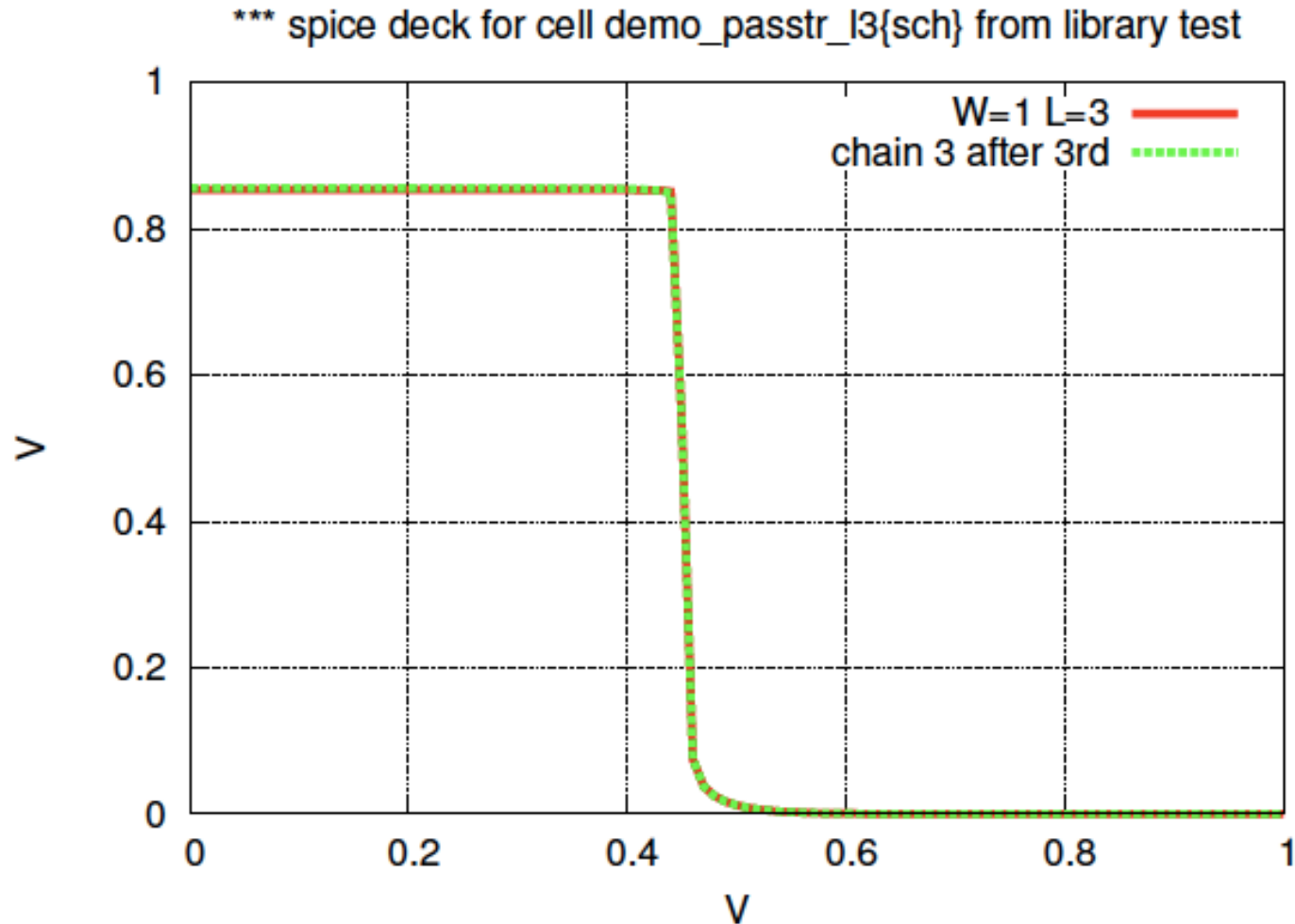

Conclude

- Can chain any number of pass transistors and only drop a single V_{th}

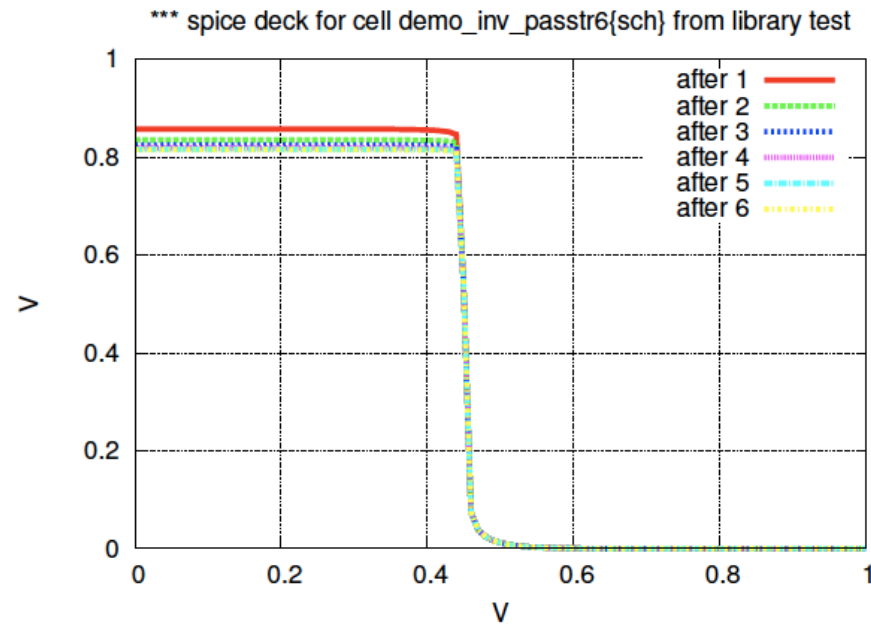
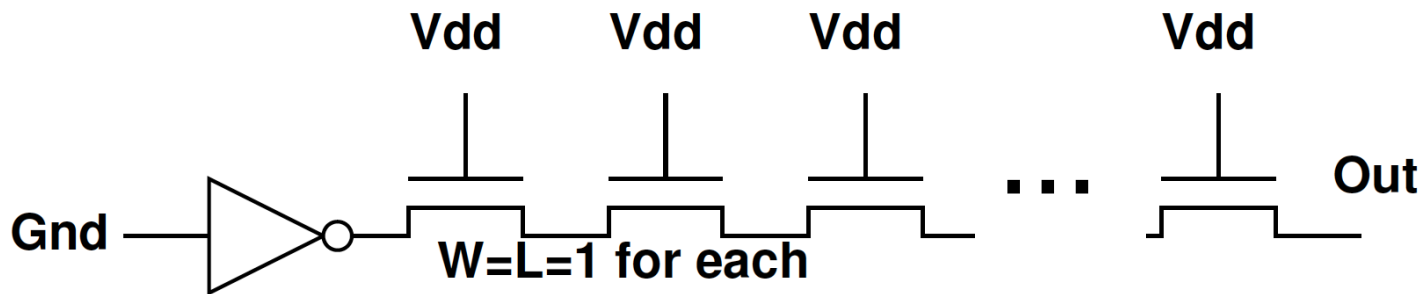



Transient

Transient Response for pass tr cascade

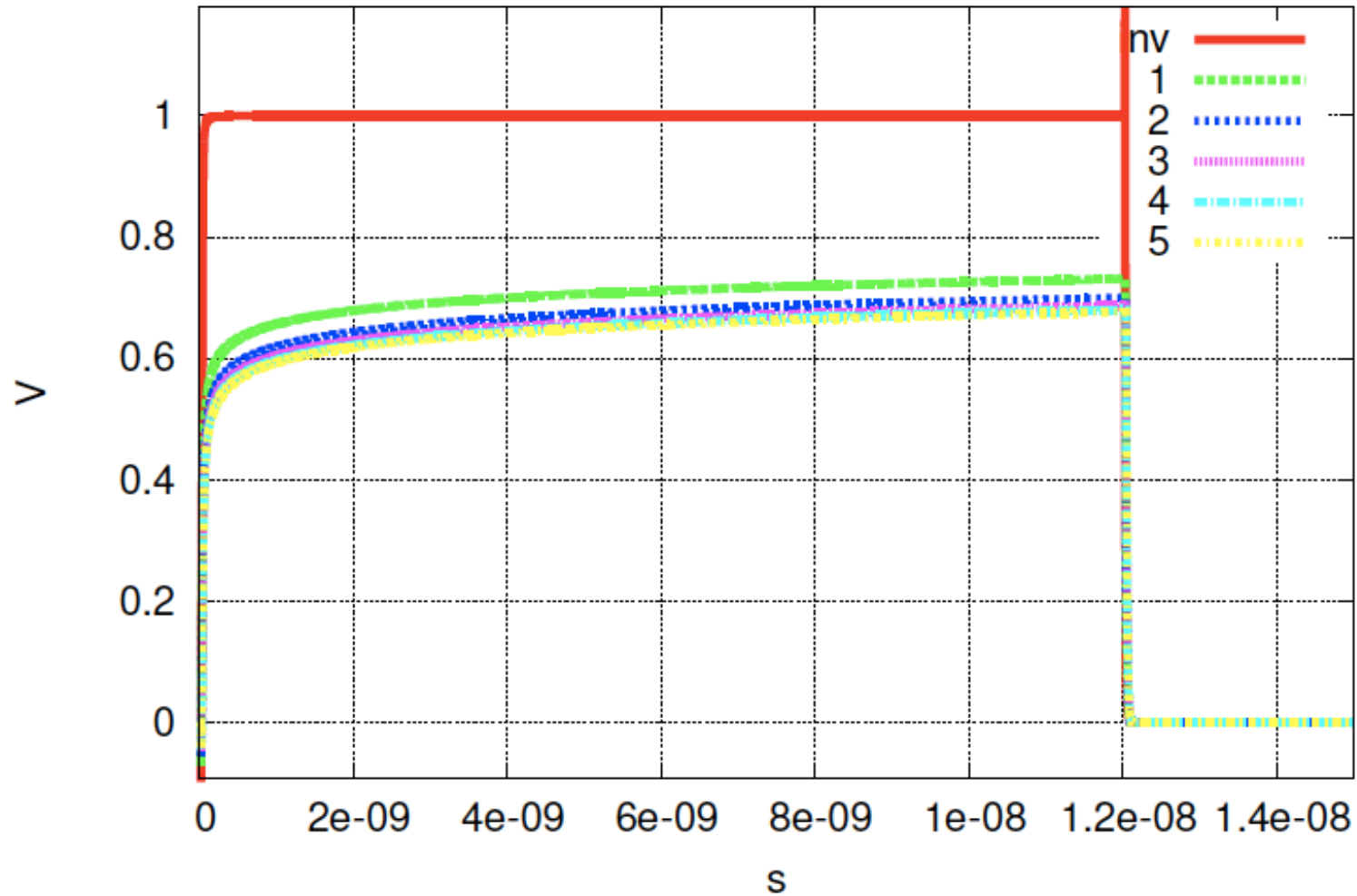



Transient: Zoomed Closeup

Transient Response for pass tr cascade

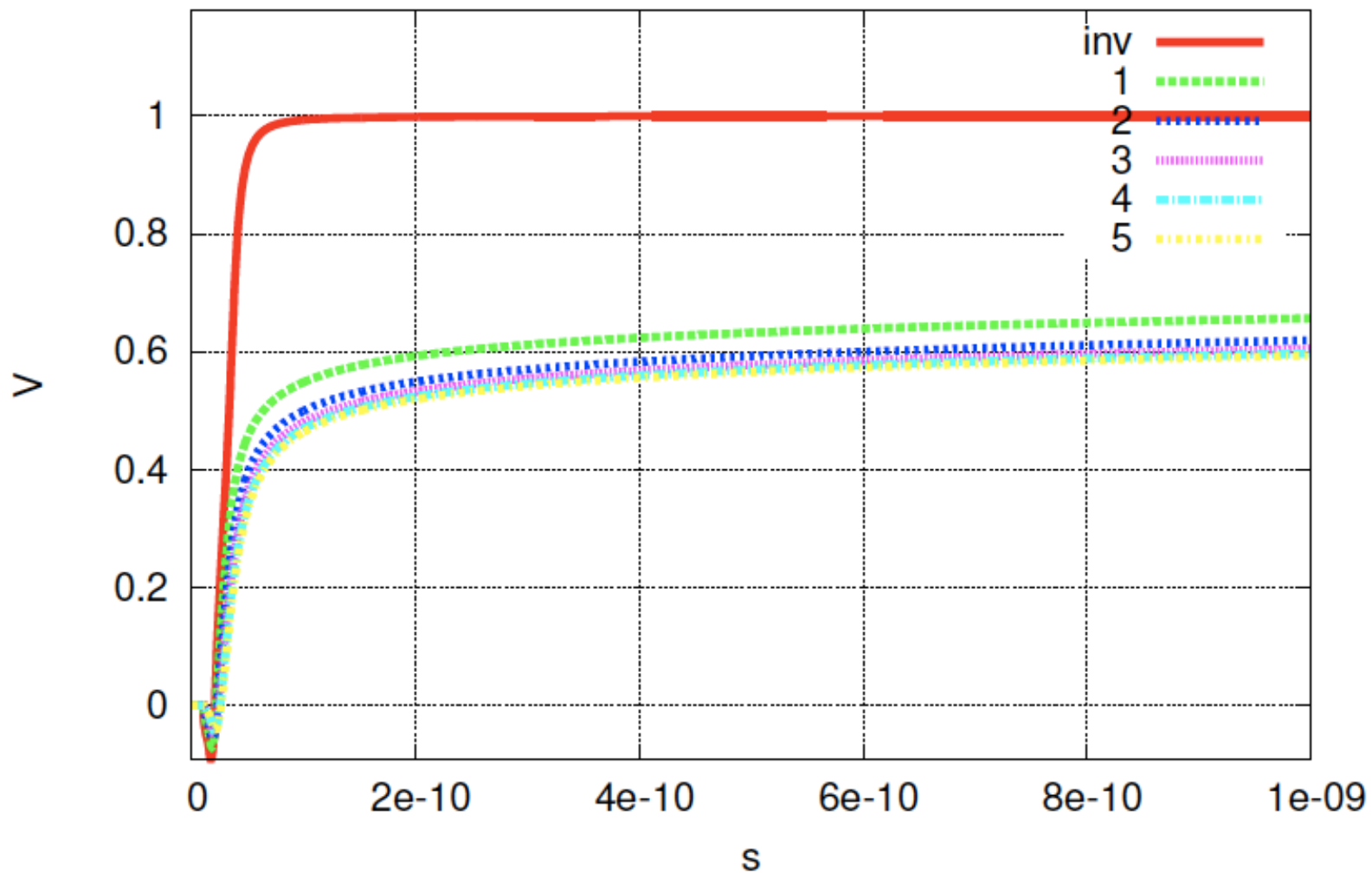



Capacitance

- What is output capacitance per stage?
 - I.e. What is the capacitance at output y ?

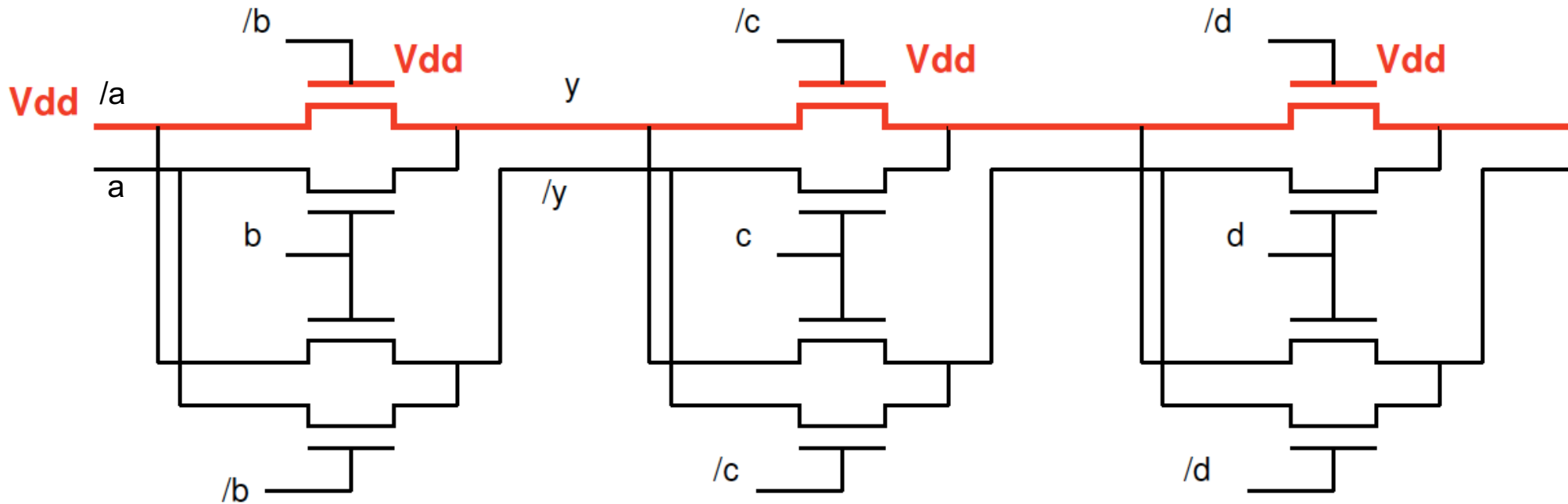



Delay Setup

- What does RC circuit look like?

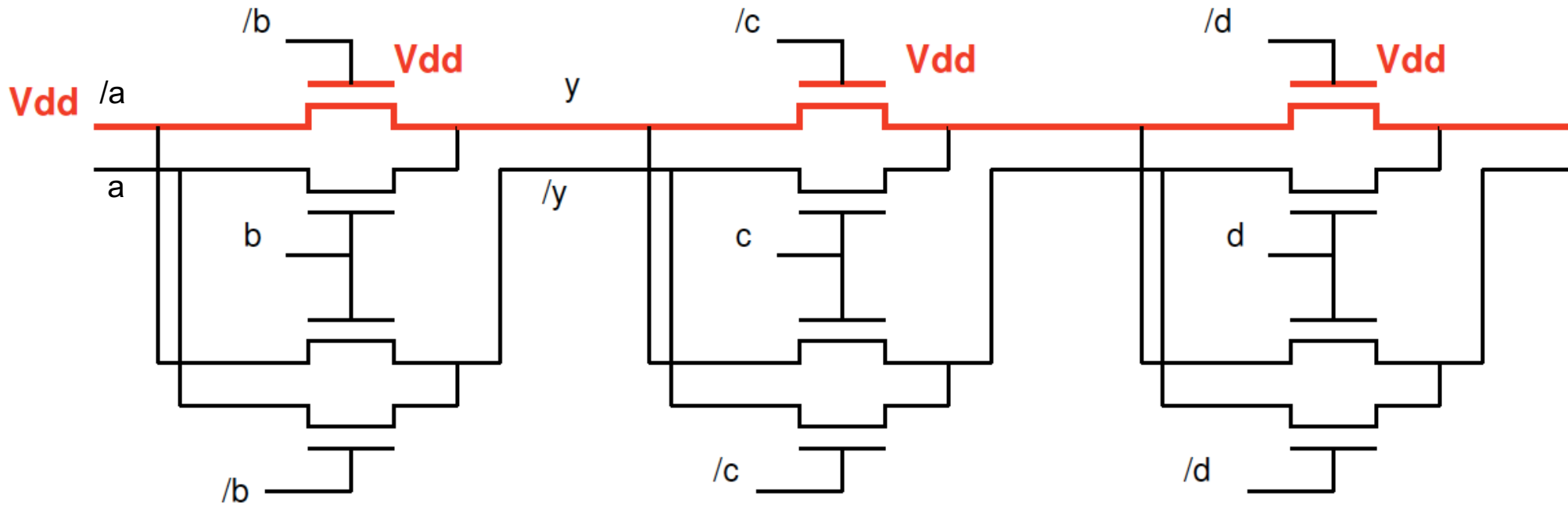

Gate Cascade? (Preclass 5)

□ What are the voltages?

$$V_{dd} = 1V$$

$$V_{thn} = -V_{thp} = 0.3V$$

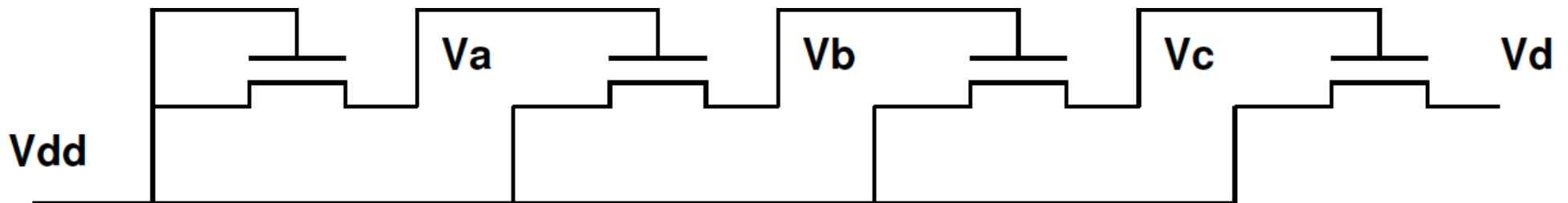



Conclude

- ❑ Cannot cascade degraded inputs into **gates**.

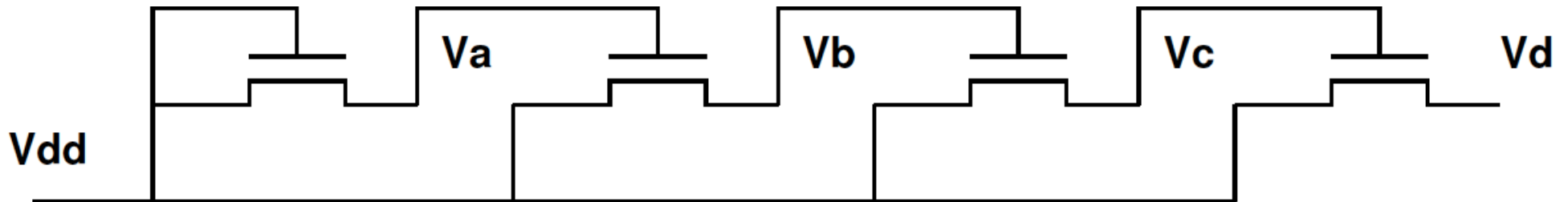



Idea

- ❑ There are other circuit disciplines
- ❑ Can use pass transistors for logic
 - Even chains of pass transistors
 - Mostly gives area win, sometimes gives delay win
 - Will talk more about delay on Wednesday
- ❑ Do not cascade as easily as CMOS



Admin

- Project 1 out now
 - Design 8-bit ripple-carry adder
 - You already know how to do this
 - Refresh yourself on binary addition of 2 bits
 - Work **individually**
 - Full Report due F 3/28
 - **Can't pass the class if you don't turn in projects**
 - Can't do project last minute



Logic Types

- ❑ CMOS Gates
 - Dual pull-down and pull-up networks, only one enabled at a time
 - Performance of gate is strong function of the fanin of gate
 - Techniques to improve performance include sizing, input reordering, and buffering (staging)
- ❑ Ratioed Gates
 - Have active pull-down (-up) network connected to load device
 - Reduced gate complexity at expense of static power asymmetric transfer function
 - Techniques to improve performance include sizing to improve noise margins and reduce static power
- ❑ Pass Gates
 - Implement logic gate as switch network for reduced area and load capacitance
 - Long cascades of switches result in quadratic increase in delay
 - Also suffer from reduced noise margins (V_T drop)
 - Use level-restoring buffers to improve noise margins



Acknowledgement

- ❑ Prof. André DeHon (University of Pennsylvania)
- ❑ Prof. Tania Khanna (University of Pennsylvania)