

N-type MOSFET

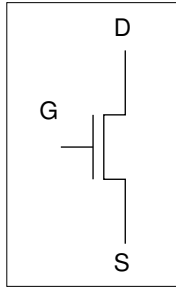

Zero-Order Model

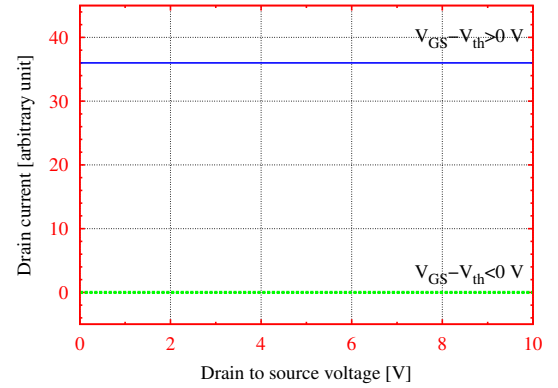
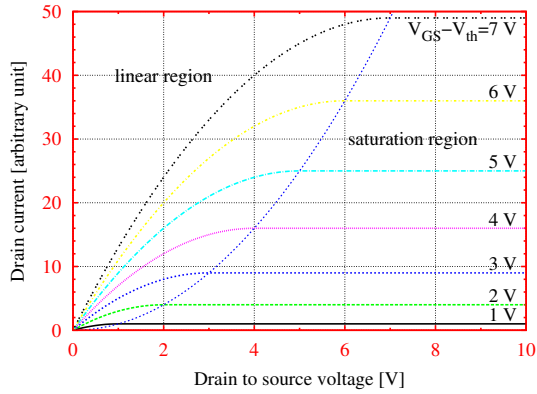
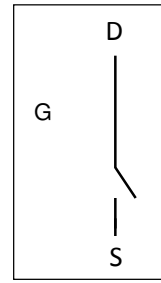

I_{ds} unbounded when $V_{gs} > V_{th}$

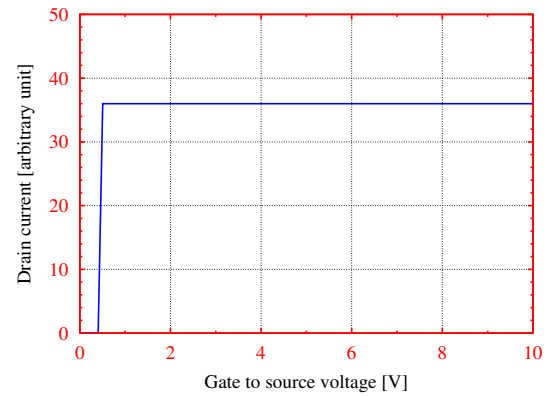
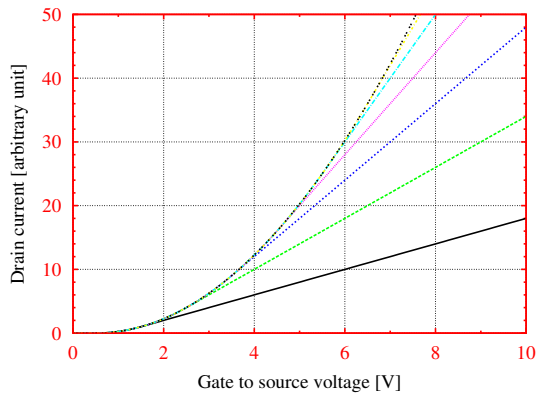

Step at $V_{gs} = V_{th}$

(even this is a simplified approximation)

	NMOS	PMOS
Threshold	$V_{thn} > 0$	$V_{thp} < 0$ $V_{thp} \approx -V_{thn}$
Conduct	positive input $V_{gs} > V_{thn}$	negative input $V_{gs} < V_{thp}$
Drain	most positive terminal	most negative terminal
Source	most negative terminal (source of electrons)	most positive terminal (source of holes)

$$V_{gs} = V_g - V_s \tag{1}$$

1. Simplify the boolean expression $Z = \bar{A} \cdot \bar{B} + A \cdot \bar{B} + \bar{A} \cdot B$ to the minimum sum of products with the 2-variable K-map:

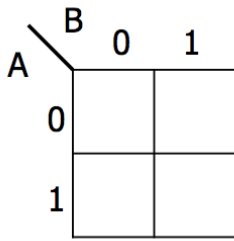

2. Simplify the boolean expression $Z = \bar{A} \cdot \bar{B} \cdot \bar{C} + \bar{A} \cdot B + A \cdot B \cdot \bar{C} + A \cdot C$ to the minimum sum of products with the 3-variable K-map:

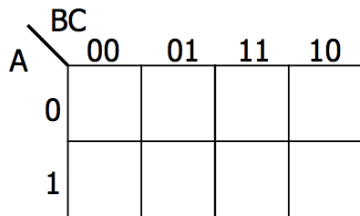

3. What function does this circuit implement? (inputs are a and b)

[N.B. crossing wires with no dot are **not** connected.]

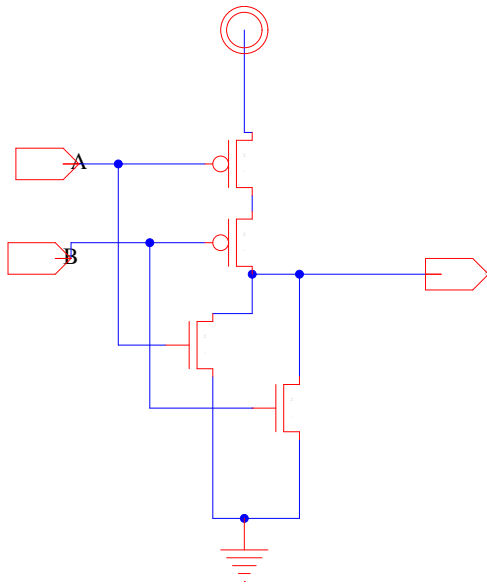

4. If $\bar{f} = a + b$, what is f in minimum-sum-of-products form?

[N.B. $\bar{f} = \sim f = /f = (\text{not } f) = f'$]

5. Design gate to perform: $f = (\bar{a} + \bar{b}) \cdot \bar{c}$

General form for Static CMOS Gate:

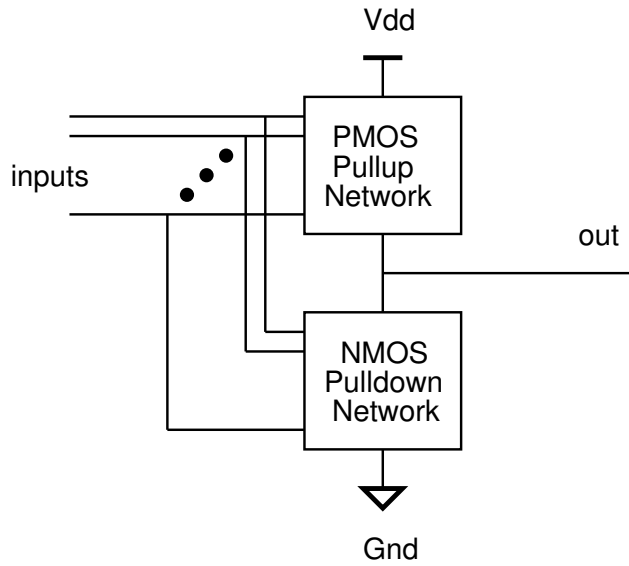

6. Extra practice for outside of class:

Simplify the boolean expression $Z = A \cdot B \cdot C + A \cdot B \cdot \bar{C} + \bar{A} \cdot B \cdot C$ to the minimum sum of products with the 3-variable K-map:

		BC			
		00	01	11	10
A	0				
	1				

Simplify the truth table to the minimum sum of products with the 4-variable K-map:

A	B	C	D	Z
0	0	0	0	1
0	0	0	1	1
0	0	1	0	1
0	0	1	1	1
0	1	0	0	1
0	1	0	1	1
0	1	1	0	1
0	1	1	1	1
1	0	0	0	0
1	0	0	1	1
1	0	1	0	0
1	0	1	1	1
1	1	0	0	0
1	1	0	1	0
1	1	1	0	0
1	1	1	1	0

		CD			
		00	01	11	10
AB	00				
	01				
	11				
	10				